

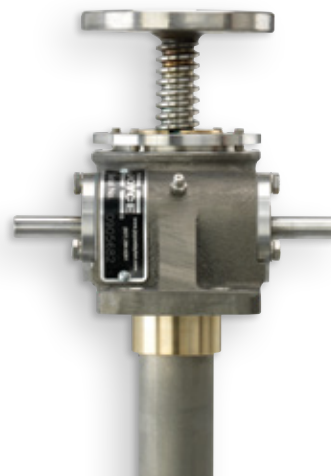

# SCREW JACKS AND LINEAR ACTUATORS

- Machine Screw Jacks
- Ball Screw Jacks
- ComDRIVE® Actuators
- Metric Screw Jacks
- Electric Cylinders
- Integrated Actuators
- Linear Actuators
- Stainless Steel Screw Jacks
- Bevel Gear® Jacks
- Bevel Ball Actuators
- Protective Boots
- Limit Switches
- System Accessories



# JAX<sup>®</sup> Online – The Fastest Way to Your Ideal System

## Web-based Linear Motion Design Software

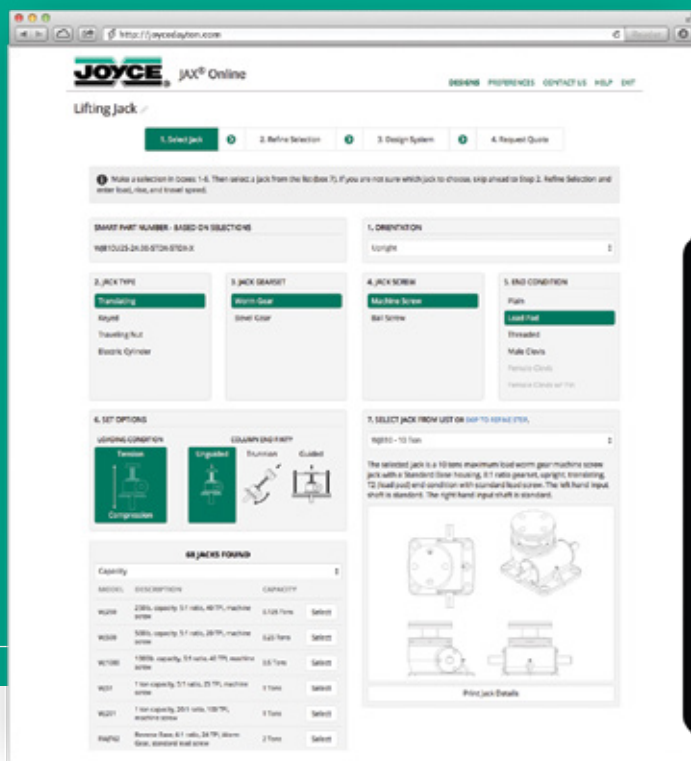

Easy-to-use JAX<sup>®</sup> Online software enables you to specify the right jacks and components for your ideal lifting and positioning systems. You can start with a complete set of requirements, or just a few simple inputs, and let JAX Online suggest components that are right for your application. The detailed reports created are complete and ideal for inclusion in technical project files, saving you time and minimizing headaches.

### Use JAX Online to:

- Size jacks and complete systems, from any computer
- Automatically configure and download 2D and 3D models of specific jacks
- Save files to your private account and return to your designs at anytime
- Evaluate multiple combinations and options before choosing your final design
- Automatically generate a bill of materials in real-time
- Request a quote and transmit your requirements with a single click

JAX Online is one more example of how Joyce is committed to providing designers and engineers with the tools they need to succeed.



Create your account and start designing  
right away at [www.joycedayton.com/jax](http://www.joycedayton.com/jax)

1-800-523-5204 | [sales@joycedayton.com](mailto:sales@joycedayton.com)



# TABLE OF CONTENTS

<b>Engineering Information</b>	
Jack Cutaway Illustrations.....	4
Quick Reference Guide.....	6
Options Overview.....	7
Selection Guide Worksheet – Jacks and Actuators.....	8
Selection Guide Worksheet – Controls.....	9
Product Selection Factors.....	10
Column Load Factors.....	11
Jack Designs.....	12
Torque and Horsepower.....	13
Options, Accessories and Controls.....	14
FAQ.....	16
<b>Machine Screw Jacks .....</b>	<b>18</b>
Ordering Information.....	20
<b>Machine Screw ComDRIVES® .....</b>	<b>45</b>
Ordering Information.....	46
<b>Stainless Steel Screw Jacks.....</b>	<b>58</b>
Ordering Information.....	60
<b>Metric Screw Jacks.....</b>	<b>71</b>
Ordering Information.....	72
<b>Ball Screw Jacks .....</b>	<b>80</b>
Ordering Information.....	82
<b>Ball Screw ComDRIVES .....</b>	<b>102</b>
Ordering Information.....	104
<b>Electric Cylinders .....</b>	<b>118</b>
Ordering Information.....	120
<b>Integrated Actuators .....</b>	<b>135</b>
Ordering Information.....	137
<b>Linear Actuators.....</b>	<b>143</b>
This product is no longer available.....	144
<b>Bevel Gear® Jacks .....</b>	<b>148</b>
Ordering Information.....	150
<b>Bevel Ball Actuators .....</b>	<b>159</b>
Ordering Information.....	160
<b>Options, Accessories and Controls .....</b>	<b>168</b>
Boots for Machine Screw Jacks.....	170
Boots for Ball Screw Jacks.....	171
Boots for KFTN Jacks.....	172
Limit Switches.....	174
Geared Potentiometers.....	175
Encoders.....	176
Servo Motor Mounts.....	178
Motor Mounts and Stock Motors.....	179
Hand Wheels and Counters.....	180
Anti-Backlash Designs.....	181
Finishes.....	182
Trunnion Mounts.....	183
Pillow Blocks and Flange Blocks.....	184
Miter Gear Boxes.....	185
Couplings.....	188
Shafting.....	190
Motor Controls.....	192
Common System Arrangements.....	195

ENGINEERING INFORMATION

MACHINE SCREW JACKS

MACHINE SCREW ComDRIVES®

STAINLESS STEEL SCREW JACKS

METRIC SCREW JACKS

BALL SCREW JACKS

BALL SCREW ComDRIVES®

ELECTRIC CYLINDERS

INTEGRATED ACTUATORS

LINEAR ACTUATORS

BEVEL GEAR® JACKS

BEVEL BALL ACTUATORS

OPTIONS, ACCESSORIES  
AND CONTROLS

# WORMGEAR STYLE JACK UPRIGHT TRANSLATING STYLE SHOWN

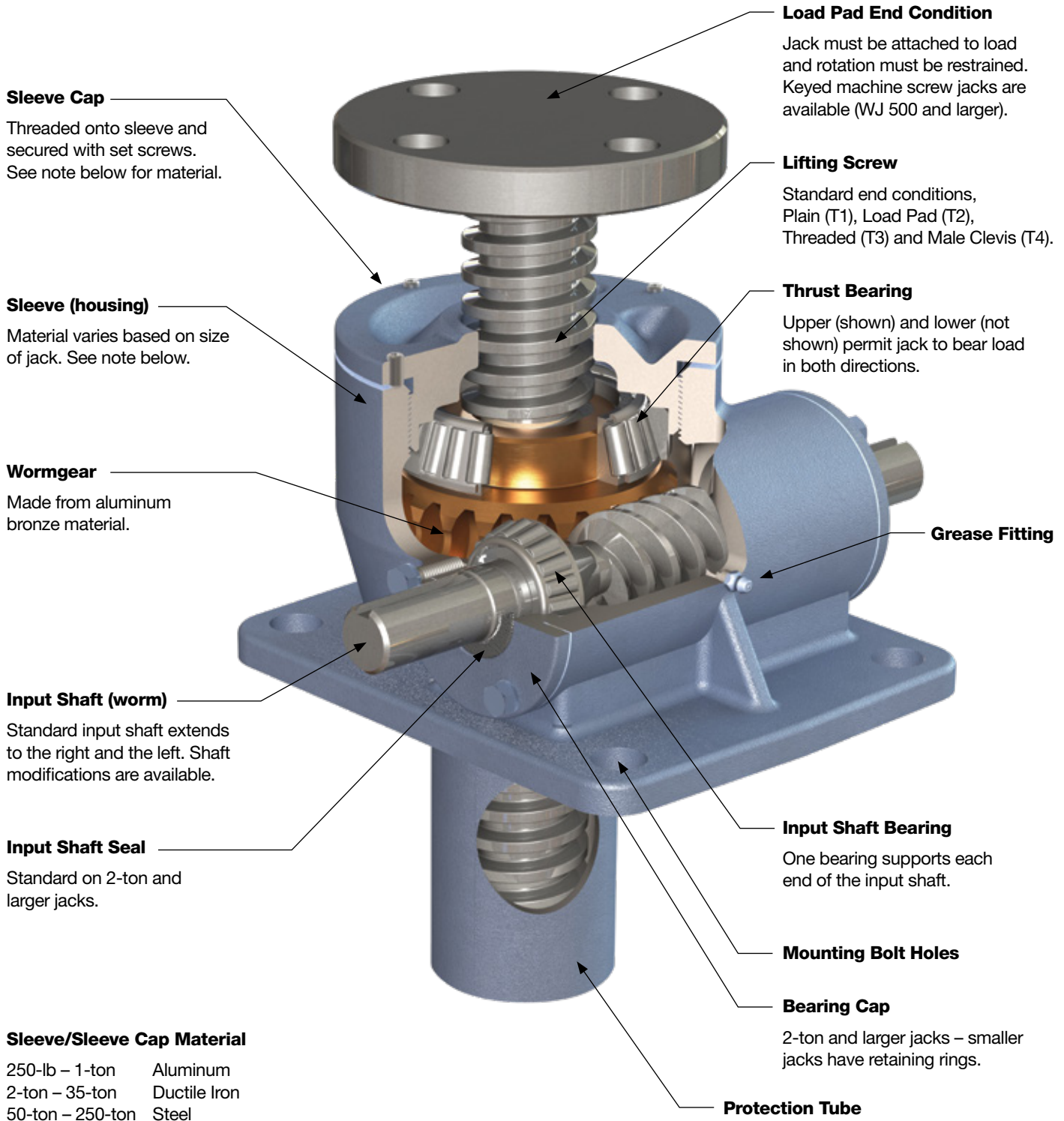

## Sleeve/Sleeve Cap Material

250-lb – 1-ton	Aluminum
2-ton – 35-ton	Ductile Iron
50-ton – 250-ton	Steel

## Options

2-ton	Stainless Steel
5-ton – 25-ton	Stainless Steel
5-ton – 35-ton	Steel

# BEVEL GEAR STYLE JACK UPRIGHT TRANSLATING STYLE SHOWN

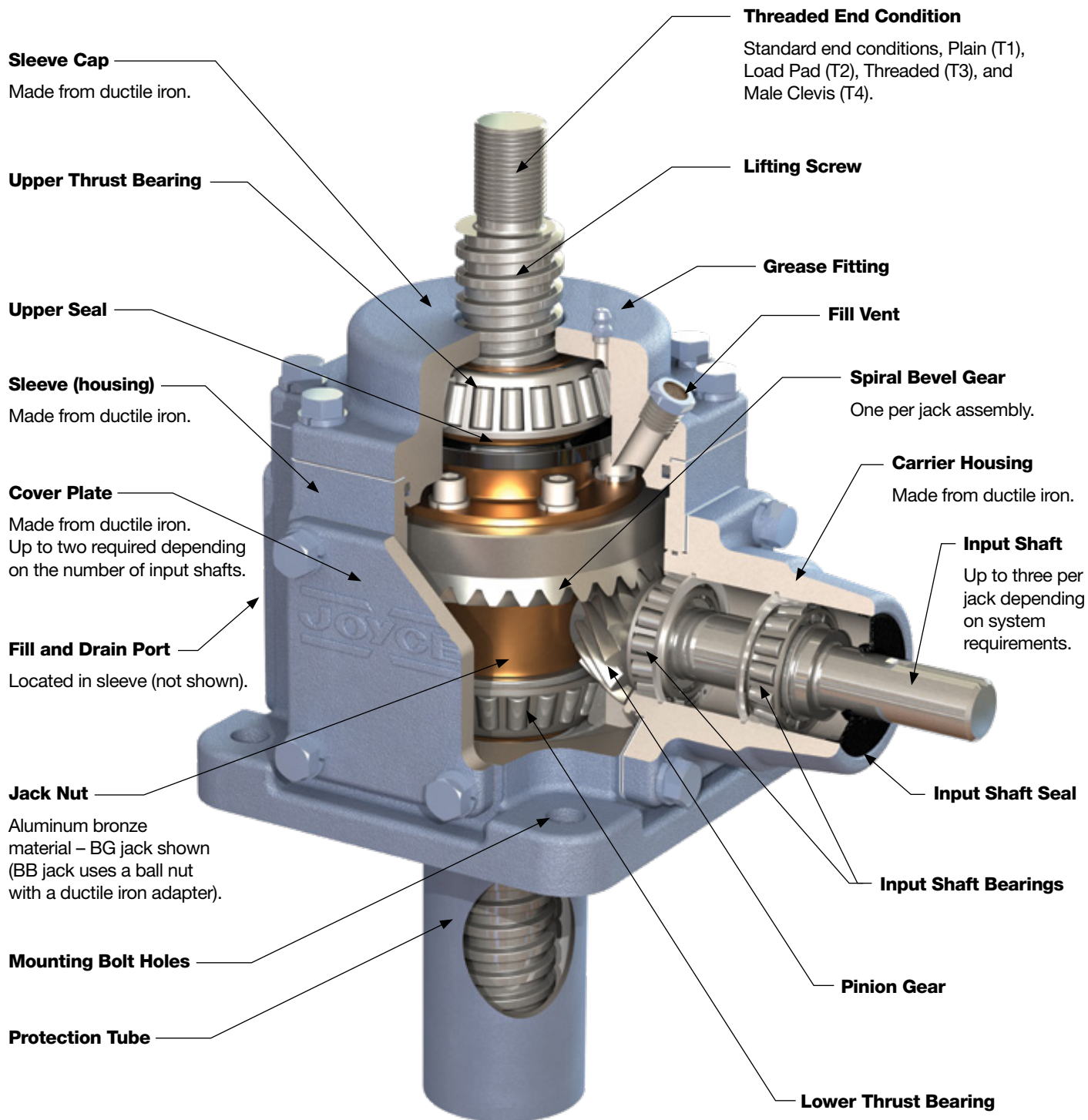

This graphic shows a Joyce Bevel Gear® jack (BG). Bevel ball actuators (BB) also use a bevel gear set. See pages 148 - 167 for more information.

# QUICK REFERENCE GUIDE

Product	Prefix	Capacity Range (tons)	Typical Lifting Speeds (IPM)	Input Shaft		Predictable Life	Inherently Self-Locking	Corrosion Resistant	Enclosed Screw	Options			
				In-Line	Right Angle					Keyed for Non-Rotation	Limit Switch	Direct Drive Motor Mount	Anti-Backlash or Limited End Play
Machine Screw Jack (pp. 18-44)	WJ RWJ DWJ DRWJ	1/8-250	14-55	■			A WJ, RWJ	C		■	■	■	■
Machine Screw ComDRIVE® (pp. 45-57)	CD DCD	2-30	2-35	■			A CD	C		■	■		■
Stainless Steel Jack (pp. 58-70)	SWJ RSWJ DSWJ DRSWJ	2-25	14-55	■			A SWJ, RSWJ	■		■	■	■	■
Metric Jack (pp. 71-79)	MWJ	1-10 (10-100 Kn)	14-55 (6-23 mm/sec)	■			■	C		■	■	■	■
Ball Screw Jack (pp. 80-101)	WBL HWBL WB HWB	1-50	14-300	■		■ Screw Only		C			■	■	D
Ball Screw ComDRIVE® (pp. 102-117)	CDB CDBL	2-30	2-55	■		■ Screw Only		C			■		D
Electric Cylinder - Standard (pp. 118-134)	ECA ECB	2 1/2-20	15-540	■		■ ECB Screw Only	B ECA	C	■		■		D
Electric Cylinder - Motor Mount (pp. 118-134)	ECA ECB	2 1/2-20	18-540	■		■ ECB Screw Only	B ECA	C	■		■	■	D
Electric Cylinder - ComDRIVE® (pp. 118-134)	ECA ECB	2 1/2-20	15-104		■	■ ECB Screw Only	B ECA	C	■		■		D
Integrated Actuator (pp. 135-142)	IA DIA BIA HBIA	1	15-350	■		■ BIA, HBIA Screw Only	■ IA	C	■		■	■	D
Bevel Gear® Jack (pp. 148-158)	BG	5-60	50-130	■	■		A Single Lead	C		■	■		
Bevel Ball Actuator (pp. 159-167)	BB	5-60	15-600	■	■	■		C			■		D

**A** Jacks with single lead screws are self-locking. Double lead screw jacks may lower under load.

**B** ECA jacks that are ≤ 30% efficient are self-locking.

**C** Joyce offers a variety of finishes and modifications that resist corrosion (p. 182).

**D** Oversized ball bearings can be added to limit the end play between the ball screw and ball nut.

# OPTIONS OVERVIEW FOR JACKS AND ACTUATORS



## Protective Boots (pp. 170-173)

- Protection from dirt and dust
- Guard against moisture
- Guard against corrosive contaminants
- Neoprene coated nylon (std)
- Special materials available



## Lubrication

- Standard grease temperature range (40°F to 220°F)
- Low temperature option
- High temperature option
- Food grade option



## ComDRIVE® Options (pp. 47 & 105)

- Special reducer ratios available
- Special mounting positions available
- Special motor adapters available
- Mount limit switch to gear reducers



## Mechanical Counters (p. 180)

- 0.001" increments (CNT0)



## Motor Mounts (pp. 178 & 179)

- NEMA mounts available on 2-ton to 20-ton wormgear jacks and electric cylinders
- NEMA mounts included on integrated actuators
- Servo motor mounts available on 2-ton to 10-ton jacks and electric cylinders, special mounts available
- Custom mounts available



## Machine Screws

- Right hand thread standard
- Left hand thread available on many models
- Special material available
- Special pitch/lead available
- Special finishes available
- Special machining options
- Special end conditions available



## Hand Wheels (p. 180)

- 4" – 12" dia. (standard)
- Aluminum (standard)
- Stainless steel available



## Screw Stops

- Standard on ComDRIVES
- Adjustable
- Bolt-on



## Finishes (p. 182)

- Enamel finish (standard)
- Epoxy finish
- STEEL IT® epoxy
- Outdoor paint process
- Custom finishes available
- Anodized (250-lb to 1-ton)
- Nickel, Xylan®, Armoloy®

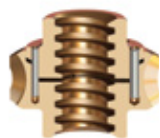

## Anti-backlash Devices (p. 181)

- Available for machine screw jacks
- Available for metric (trapezoidal) jacks
- Limits lifting screw endplay



## Ball Screw Options

- Right hand thread standard
- Left hand thread available on many models
- Special pitch/lead available
- Special finishes available
- Special machining options



## Potentiometers (p. 175)

- 0-10V (POTA)
- 4-20mA (POTB)
- 0-10V with limit switches (POTC)
- 4-20mA with limit switches (POTD)
- IP65



## Limit Switches (p. 174)

- Rotary cam (2-4 switches)
- SPDT standard
- DPDT available
- Explosion proof available



## Thrust Rings

- Used in applications where static loads exceed jack capacity



## Oversized Ball Bearings

- Available for ball screw jacks
- Limits screw backlash to 0.003"



## Wormgear Sets

- Right hand gear set standard
- Left hand available on many models
- 25:1 ratio option available on several models



## Encoders (pp. 176-177)

- Standard 200 or 1024 PPR
- Quadrature wave form
- Stainless steel encoder
- Absolute encoder



## Follower Nuts (p. 17)

- For KFTN jack
- For translating jack



## Input Shaft (worm)

- Square or hex to fit tool
- Special lengths
- 17-4 stainless steel available
- Metric diameters available
- One side can be cut off
- Other modifications available
- Input shaft cover available



# SELECTION GUIDE WORKSHEET JACKS AND ACTUATORS

Name \_\_\_\_\_ Title \_\_\_\_\_

Company \_\_\_\_\_ Project \_\_\_\_\_

Address \_\_\_\_\_

Phone \_\_\_\_\_ Fax \_\_\_\_\_ Email \_\_\_\_\_

## System Considerations

Number of Jacks \_\_\_\_\_ Load per Jack \_\_\_\_\_ System Load \_\_\_\_\_ Travel Speed \_\_\_\_\_

### Type of Gear Set

- Worm Gear
- Bevel Gear

### Type of Screw

- Machine Screw
- Ball Screw

### Configuration

- Upright
- Inverted

### Mounting Orientation

- Horizontal
- Vertical

### Load

- Tension (T)
- Compression (C)
- Both T & C

### Rise/Stroke

- \_\_\_\_\_ Inches
- \_\_\_\_\_ Millimeters

### Product Family

- Screw Jack
- Electric Cylinder
- Actuator

### Jack Design

- Translating
- Keyed (non-rotation)
- Traveling Nut (flush mount)

### End Condition

- T1 Plain
- T2 Load Pad
- T3 Threaded
- T4 Male Clevis

### Static Side Load

- Yes \_\_\_\_\_
- No

### Power Requirements

- Manual (Machine screws)
- Electrical \_\_\_\_V. \_\_\_\_Hz. \_\_\_\_ph.
- Other \_\_\_\_\_

## Environmental and Other Considerations

### Temperature

- Standard +40° F to +220° F
- + \_\_\_\_\_° F to - \_\_\_\_\_° F
- + \_\_\_\_\_° C to - \_\_\_\_\_° C

### Environment

- Dust
- Sand
- Oil
- Wash Down
- Dirt
- Water
- Outdoor

### Duty Cycle

- Cycles/Minute \_\_\_\_\_
- Cycles/Hour \_\_\_\_\_
- Cycles/Day \_\_\_\_\_

### Description of Cycle

- Frequency \_\_\_\_\_
- Dwell Time \_\_\_\_\_
- Other \_\_\_\_\_

### System Will Lift

- Full Stroke
- Partial Stroke
- Incrementally

### System Will Lower

- Full Stroke
- Partial Stroke
- Incrementally

### System Controls

- Motor Starter
- Synchronizing Controls
- Programmable Controls
- Custom Controls

## Options and Accessories

- Protective Boots
- Limit Switches
- Screw Stops
- Anti-backlash
- Motor Mount
- Servo Mount
- Motor/Brake Motor
- Hand Wheel
- Food Grade Grease
- Outdoor Paint
- Epoxy Paint
- Trunnion Mount
- Miter Gear Box
- Gear Reducer
- Shafting/Couplings
- Stainless Steel
- Encoder
- Counter
- Geared Pot.
- Pillow Blocks

Please list additional information and include a drawing of your application.

---



---



---

Joyce/Dayton Corp. • P.O. Box 1630, Dayton OH 45401 • sales@joycedayton.com • (Fax) 937-297-7173







# SELECTION GUIDE WORKSHEET CONTROLS

Name \_\_\_\_\_ Title \_\_\_\_\_

Company \_\_\_\_\_ Project \_\_\_\_\_

Address \_\_\_\_\_

Phone \_\_\_\_\_ Fax \_\_\_\_\_ Email \_\_\_\_\_

## System Information

Number of Jacks \_\_\_\_\_ Number of Motors \_\_\_\_\_

Are Jacks:  Mechanically Synchronized  Electrically Synchronized  Independently Operated

### System Environment

- Indoor/General Purpose
- Outdoor
- Wash Down
- Explosion Proof
- Coastal/Salt Spray

### Approvals

- UL Listed

### What aspect of operation needs to be controlled?

- Position
- Travel Speed
- Both Position and Travel Speed
- Other (Leveling)

### Motor Requirements

Voltage \_\_\_\_\_  
 Phase \_\_\_\_\_  
 Frequency \_\_\_\_\_

Brake required  YES  NO

Brake Wiring  Internal

External (for variable frequency drives)

### Motor Operation

- Variable Speed
- Constant Speed
- Inch/Jog (incremental)
- Synchronous

### Primary Control Requirement (check all that apply)

- |  |  |
|--|--|
| <input type="checkbox"/> Momentary Operation                       | <input type="checkbox"/> Maintained Operation                                |
| <input type="checkbox"/> Constant Torque                           | <input type="checkbox"/> Synchronized Travel                                 |
| <input type="checkbox"/> Programmable Positions                    | Tolerance ____ +/- <input type="checkbox"/> inch <input type="checkbox"/> mm |
| <input type="checkbox"/> One to Four                               | <input type="checkbox"/> Variable Speed                                      |
| <input type="checkbox"/> More than Four                            | Range of frequency _____   |
| <input type="checkbox"/> Positioning Tolerance                     | <input type="checkbox"/> Soft Start Operation                                |
| ____ +/- <input type="checkbox"/> inch <input type="checkbox"/> mm | <input type="checkbox"/> Rate (in/min <sup>2</sup> ) _____                   |
|  | <input type="checkbox"/> Number of starts/hour _____                         |

### Control Options

- Alarms       Indicators       Pendant Control       Wireless Control       HMI/Touch Screen

### Other Considerations

Please list in detail any other specific features desired:

---



---



---

### Complete this worksheet and fax or email to Joyce/Dayton

Joyce/Dayton Corp. • P.O. Box 1630, Dayton OH 45401  
 800-523-5204 • 937-294-6261 • (Fax) 937-297-7173 • sales@joycedayton.com

- 1. Maximum Input RPM** – Input rotational speeds up to 2400 RPM are permissible for jacks and actuators depending on load, duty cycle, and other factors specific to the application. Use our exclusive JAX® Online browser-based software to evaluate jacks and systems having input RPM values  $\geq$  to 1750 RPM.
- 2. Side Load** – Standard jacks and actuators are not designed for dynamic side loads. The load must be positioned axially. Static side loads are limited. Contact Joyce for technical assistance.
- 3. Duty Cycle** – Relationship between operation time and rest time. The allowable duty cycle for jacks and actuators is based upon several application variables such as load, speed, and temperature. Consideration must be given to the severity of the duty cycle during the product selection phase. Our Application Engineers are available to discuss your requirements.
- 4. Self-Locking Jacks** – Screw jacks that require power to raise or lower. Exceptions include machine screw jacks having double lead screws and ECA electric cylinders that are more than 30% efficient and all ball screw jacks. A brake must be used on the input shaft of any jack that is not self-locking. A brake should also be included for applications that expose the jack or actuator to vibration. Contact Joyce for more information.
- 5. Jacks That Require a Brake Motor** – Any jack that will lower under load requires a brake motor. This includes ball screw jacks (WB, HWB, WBL, HWBL), ball screw ComDRIVES® (CDB, CDBL, CDHB, CDHBL), ball screw electric cylinders (ECB), ball screw integrated actuators (BIA, HBIA), and bevel ball actuators (BB). Machine screw jacks with double lead screws and WJ500 jacks may also require brakes to hold position.
- 6. Travel Speed Limitations** – Typical travel speeds for various jacks and actuators are measured in inches per minute (IPM). Speeds depend on the input RPM, load, internal ratio and lead of the screw. Maximum allowable travel speeds for machine screw jacks are typically slower than ball screw jacks. Wormgear jacks typically have slower travel speeds than bevel gear jacks. Refer to the JAX Online browser-based software for more detail or contact Joyce to talk with an application engineer.
- 7. Maximum Screw Length** – Maximum distance from the base of the jack to the end of the extended screw. It is limited by the column load in compression. Refer to column load charts throughout this catalog or use the JAX Online browser-based software. Contact Joyce with questions.
- 8. Calculated Life for Machine Screws** – There is no formula available to calculate the life of a machine screw. If a calculated life for the screw jack is required, specify ball screw jacks, ball screw ComDRIVES®, ball screw electric cylinders, ball screw integrated actuators, or bevel ball actuators.
- 9. Calculated Life for Ball Screws** – The calculated life for ball screws is based on the ball nut life. This information is available for all ball screw jacks, ball screw ComDRIVES®, ball screw integrated actuators, bevel ball actuators, and ball screw electric cylinders (ECB). Register at [joycedayton.com/register](http://joycedayton.com/register) to use JAX Online browser-based software, or contact Joyce with your requirements.
- 10. Screw Stops** – Stops are offered as options for screw jacks and actuators, and are not to be used as operating limits. Engaging the stop may prevent damage to your structure but will most likely damage the jack. To control jack or actuator travel, include travel limits in the system design. Stops may increase the closed height of the jack and the length of the protection tube. Refer to specific ordering sections in the catalog or contact Joyce for more information.  
**Note:** *Adjustable screw stops are standard on most Joyce ComDRIVE® jacks. (The extending stop on 15- and 50-ton jacks and ComDRIVES is threaded on and functions as a fixed stop.)*
- 11. Adjustable or Fixed Screw Stops** – Adjustable screw stops are used most frequently. They are secured against the lifting screw with set screws and can easily be repositioned. Fixed screw stops are positioned at the factory and their position cannot be adjusted. Fixed extending screw stops, when used, are standard on extending stops for both 15- and 50-ton machine screw jacks.
- 12. Hard Stops** – Jacks are not designed to operate into a hard stop. Sudden impacts and shock loads may cause damage to jacks and actuators. Customers are responsible for providing travel limits to avoid this situation.
- 13. Standard Operating Temperature** – The standard operating temperature range for most products is 40°F – 220°F. There are some exceptions. For operation outside this range, special lubricants and seals can be provided.
- 14. Lubrication of Wormgear Jacks** – Standard wormgear jacks are lubricated with NLGI grade #1 grease prior to shipment. Specific information and commercial brand names can be found in the Operation & Maintenance Manuals, which are available at [joycedayton.com](http://joycedayton.com).
- 15. Lubrication of Bevel Gear Jacks** – Bevel Gear jacks use both NLGI grade #1 grease and oil. The upper bearing and jackscrew are grease lubricated while the remaining internal components are oil lubricated. These jacks are grease lubricated prior to shipment; however, oil must be added to the unit prior to operation. Bevel Ball Actuators are typically grease lubricated with NLGI grade #1 grease prior to shipment.
- 16. Horizontal Mounting** – When jacks are mounted horizontally, Joyce recommends that the input shaft (worm) be mounted below the lifting screw and parallel with the horizon. This position provides the most lubrication to the input shaft (worm), and to both worm shaft bearings. The load capacity of the jack may be reduced when the lifting screw is mounted horizontally. Bevel gear jacks are designed to be mounted vertically with the flange base down but can be adapted for other mounting orientations. Consideration must be given to the position of vents and oil fittings to ensure proper lubrication levels.
- 17. High Screw RPM and Long Screw Lengths** – Keyed for traveling nut (KFTN) jacks with long screw lengths require additional support when the screw rotates at high RPM.
- 18. Direct Drive Considerations** – Whenever the input worm shaft is driven directly from a motor, designers should consider the starting torque capacity of the motor, handwheel, or other power train device. Torque values calculated in JAX Online software are based on running torque and selection of motor horsepower may require additional consideration.

### Technical Questions

Our qualified and experienced Application Engineers are available Monday through Friday, 8 a.m. - 5 p.m., EST.

Contact Joyce to discuss specific application questions and technical questions.

- [sales@joycedayton.com](mailto:sales@joycedayton.com)
- 800-523-5204 (USA and Canada)
- 937-294-6261

### Tools for Engineers and Designers

Register at [joycedayton.com/user/register](http://joycedayton.com/user/register) to access 2D/3D drawing software and our exclusive JAX® Online browser-based software.

### Column Loading Capacity

The type of load on a jack, and the way the jack is mounted, affects its load bearing capacity. There are two types of possible jack loads, tension and compression. A jack is under tension when its load pulls the screw away from the jack. It is under compression when the load pushes the lifting screw toward the jack (see diagrams). A jack can be under tension or compression regardless of jack positioning (i.e., vertical, horizontal, upright, or inverted).

When tension loaded, the jack retains full rated capacity. Under compression loads, the screw may not be able to support full capacity. For example, a 2-ton jack with a 15" screw length will be limited to 2293 pounds in compression, about half the jack's capacity. In compression the load, screw length and jack mounting configuration determine the load capacity of the screw. The examples shown illustrate four common mounting configurations.

#### Unguided

If the screw is the only support for the load, it is considered unguided. The screw must be large enough to support the load and prevent buckling. On the Column Loading charts, use the row labeled "unguided" for the allowable lengths for this design. The Column Loading charts are located within the appropriate product sections of the catalog.

#### Trunnion Mounting

In a trunnion mounting arrangement, the screw has a pivot on the end and the jack body is mounted on a large pivoting frame, or trunnion. This type of mounting is particularly common in the antenna industry. In practice, the pivot should be as close to the centerline of the internal nut as design permits. This will eliminate moment loads caused by loose threads. Use the "trunnion" row on the Column Loading charts found within the appropriate product sections of the catalog.

#### Guided

Guided loading is often termed "fixed-fixed" loading. With guided loading, both ends of the column are rigidly held – the jack body is bolted firmly to a sturdy base, and the load travels on slides, bearings, rollers or other means. The guides should be snug enough to prevent any side load or moment load from reaching the screw. Use the "guided" row on the appropriate Column Loading charts.

#### Double-Clevis Mounting

Double-clevis jacks have less load capacity than the other common mounting configurations. A double-clevis jack has pivots or clevises at both ends: one on the screw tip and one on the end of the protection tube. This tends to weaken it as a column by creating eccentric loads on the screw. This eccentricity tends to increase with greater distance and higher loading. For this reason, double-clevis jacks are limited both in

capacity and maximum length. Double-clevis mounting differs from trunnion mounting because the pivot is located farther from the jack body. The Column Loading charts do not apply for this mounting. Please consult Joyce for load bearing information.

#### How to use the Column Loading charts:

Note: Charts for machine screw jacks, machine screw ComDRIVES®, metric screw jacks, ball screw jacks, ball screw ComDRIVES®, stainless steel jacks, bevel gear jacks, and bevel ball actuators are located within the specific product section of the catalog. These charts only apply to jacks with axial loads. *For side loads, offset loads, and horizontal mounting, contact Joyce.*

1. Determine the type of jack you wish to use and locate that column load chart which is found near the beginning of each product section.
2. Determine the proper mounting arrangement for your application. Locate the appropriate row and find the screw length at the bottom of the chart.
3. Find the load you need to move (in pounds or kilonewtons) on the left side of the chart.
4. Find the point on the chart where the load and length intersect. Choose a jack whose line is on or above this intersection.
5. Add the length of the end condition you have chosen and any additional screw extension to the screw length to find the "unbraced" screw length. Verify your selection using the unbraced length.

#### Example:

A jack must lift 5 tons (10,000 pounds) over a distance of 31 inches. The load places the screw in compression. The jack is mounted firmly by its base, and the load is attached to a load pad (Type 2 end) and is not guided.

1. In this example, a machine screw jack will be used so locate the Column Loading chart for machine screw jacks on page 24.
2. Look at the "unguided" row at the bottom of the machine screw jack Column Loading chart and find the 31" mark.
3. From this, the 10-ton double lead jack is selected. Look at the dimensions from the jack body for the Type 2 end for this jack. The Type 2 end adds 2" from the top of the jack to the end of the screw. Thus the total unbraced length of the screw is 31" + 2" = 33".
4. Use this new unbraced screw length to verify your selection. In this case, the intersection point still falls below the 10-ton double lead jack line, so this selection is correct.

#### Compression

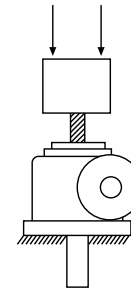

#### Tension

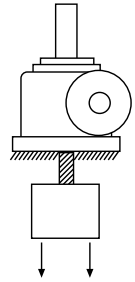

#### Unguided

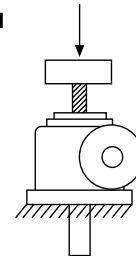

#### Trunnion Mount

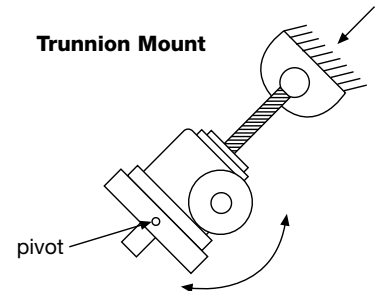

#### Guided

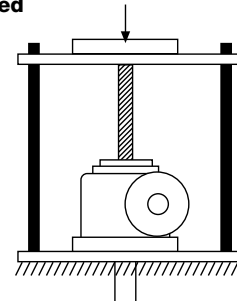

#### Double-Clevis

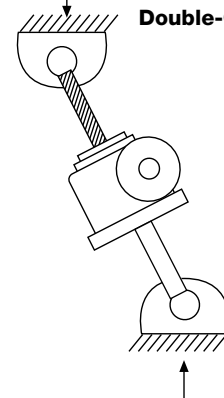

## Joyce Translating Design Jacks

A driven worm acts on an internal wormgear, which in turn drives a lifting screw to extend or retract. As the lifting screw translates through the body of the jack, inherent screw rotation is prevented by an attached load or mounting structure either of which is anchored to resist rotation.

This design is available for:

- Machine Screw Jacks
- Machine Screw ComDRIVES®
- Stainless Steel Jacks
- Metric Screw Jacks
- Ball Screw Jacks
- Ball Screw ComDRIVES®
- Bevel Gear Jacks
- Bevel Ball Actuators

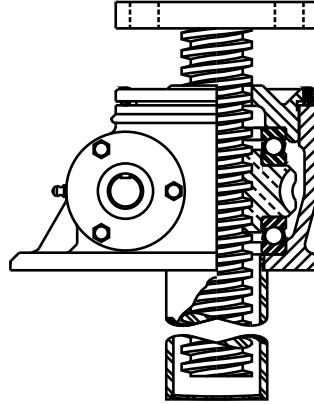

## Joyce Keyed Design Jacks

Some loads do not prevent lifting screw rotation. These applications require a keyed jack. A key, fixed to the jack housing and inserted into a keyway milled into the lifting screw, forces the lifting screw to translate without rotating. Several dimensions of the keyed jack differ from the translating jack – check the keyed jack drawings for each jack model.

This design is available for:

- Machine Screw Jacks (except WJ250)
- Machine Screw ComDRIVES®
- Stainless Steel Jacks
- Metric Screw Jacks
- Bevel Gear Jacks

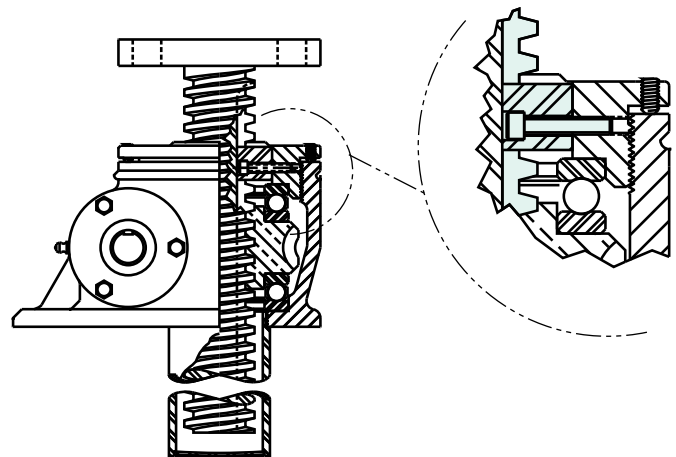

## Joyce Keyed for Traveling Nut (KFTN) Jacks

A keyed for traveling nut jack (sometimes referred to as a rotating screw jack) features a lifting screw keyed to the wormgear as a single unit, forcing the lifting screw to rotate, but not translate. A flanged traveling nut, attached to the load, is driven by the rotation of the lifting screw. This type of jack is ideal for applications that cannot accommodate a screw protection tube or that require a flush mount. Refer to the keyed for traveling nut (KFTN) dimensional drawings for each jack model.

This design is available for:

- Machine Screw Jacks
- Machine Screw ComDRIVES®
- Stainless Steel Jacks
- Metric Screw Jacks
- Ball Screw Jacks
- Ball Screw ComDRIVES®
- Integrated Actuators
- Bevel Gear Jacks
- Bevel Ball Actuators

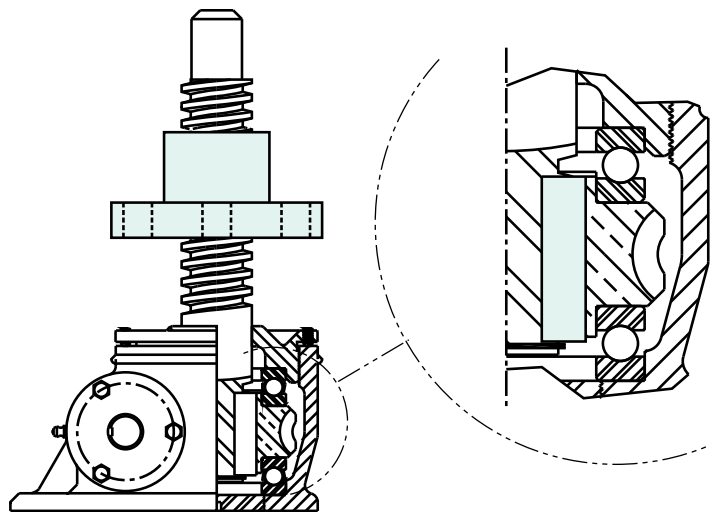

Operating Torque Constants and Tare Torque values can be found on specification pages.

Use the following formula to calculate horsepower:

$$(RPM \times Load \text{ (lb)} \times \text{Operating Torque Constant} + \text{Tare Torque}) / 63025 = \text{Horsepower}$$

### Example 1 – Calculate the horsepower needed to move a load on a single jack (WJT242).

WJT242 has a torque constant of 0.009W with (W) representing the load in pounds and a tare torque of 4 inch-pounds (page 22). Using 350 RPM on the input shaft and a 2000-pound load results in the following horsepower equation:  $(350 \text{ RPM} \times 2000 \text{ lb} \times 0.009 + 4 \text{ in. lbs}) / 63,025 = 0.10 \text{ HP}$

Note: Unlike bevel gear jacks and bevel ball actuators, wormgear style jack input torque requirements vary with input speed, therefore the constants listed in the catalog are only accurate for the RPM listed. To calculate horsepower at speeds other than those listed, please refer to the free JAX® Online browser-based software or fill out a selection guide (page 8) and contact Joyce .

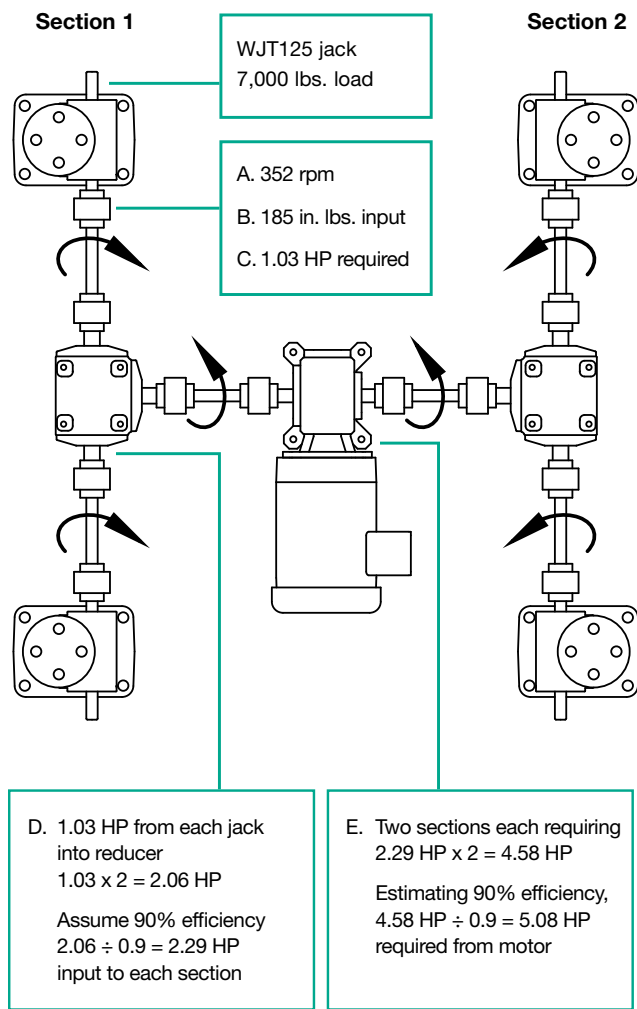

### Example 2 – Calculate the horsepower needed to move a system load (WJT125).

Find the horsepower required to raise a system load of 28,000-pounds, a distance of 10 inches, at a speed of 11 in./min., using four WJT125 jacks (page 22). The load per jack is 7000 pounds.

- Determine input speed:  
 $32 \text{ turns of the input shaft} = 1 \text{ inch of linear travel.}$   
 $(32 \text{ turns/inch} \times 11 \text{ inches/min} = 352 \text{ RPM input})$
- Determine the input operating torque plus tare torque for one jack:  
 $(0.025 \text{ in. lbs.} \times 7,000) + 10 \text{ in. lbs} = 185 \text{ in. lbs}$
- Determine the input horsepower for one jack:  
 $(352 \text{ rpm} \times 185 \text{ in. lbs}) / 63,025 = 1.03 \text{ HP per jack}$

To calculate the horsepower required when operating a jack system, it is usually easiest to separate the system into sections. For example, the “H” system can be viewed as two jack systems joined by a speed reducer in the center.

Always remember to take into account the inefficiencies of miter boxes and gear reducers when calculating system horsepower requirements. (For this exercise use 90% efficiency for miter boxes and gear reducers, but in actual systems efficiencies may differ.)

- Determine horsepower required for Section 1:  
 $\text{Total horsepower required for the left side of the system} = 1.03 \text{ HP per jack} \times 2 \text{ jacks} = 2.06 \text{ HP}$

$2.06 \text{ HP} / .9 = 2.29 \text{ HP}$  required into miter box of Section 1.  
 Since Sections 1 and 2 are identical, Section 2 also requires 2.29 HP.

- Determine horsepower required for Sections 1 and 2:  
 $2.29 \text{ HP} + 2.29 \text{ HP} = 4.58 \text{ HP}$

Account for the inefficiency of the central gear reducer to determine the total system horsepower requirement.

$4.58 \text{ HP} / 0.9 = 5.08 \text{ HP}$  required to operate this system

## SHAFT MOUNTED OPTIONS

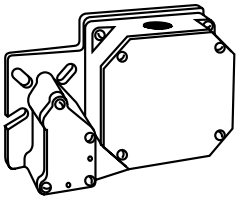

### Rotary Cam Limit Switches

See page 174

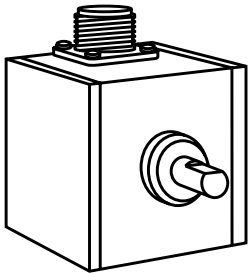

### Encoders

- Standard, 200 or Optional 1024 PPR
- Stainless steel Encoder 1024 PPM
- Absolute Encoder

See pages 176-177

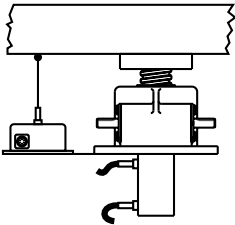

### String Encoder and other Linear Displacement devices

### Proximity Switches

Contact Joyce

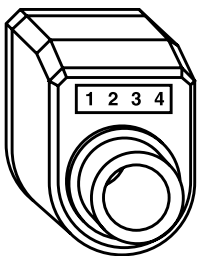

### Mechanical Counters

See page 180

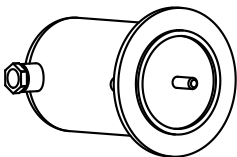

### Geared Potentiometer 0-10V or 4-20Ma

See page 175

Joyce jacks and actuators are at the heart of linear motion systems in thousands of applications worldwide.

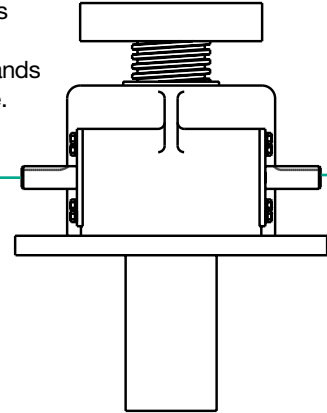

## ACCESSORIES

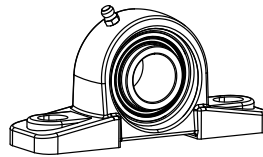

### Pillow Block and Flange Block Supports

See page 184

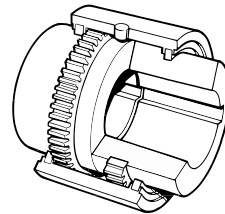

### Shafts and Couplings

See pages 188-191

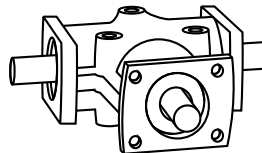

### Miter Gear Boxes

See pages 185-187

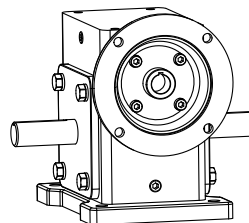

### Speed Reducers

Contact Joyce

### DRIVE OPTIONS

#### Hand Wheels

See page 180

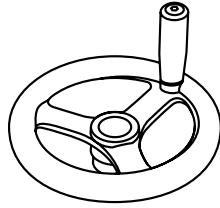

#### Square or Hex ends on worm input

Contact Joyce

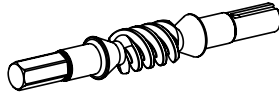

#### Specialty Motors

- AC or DC
- Air
- IEC Frame
- Gear Motor
- International Voltages
- Single Phase
- Brake Motors

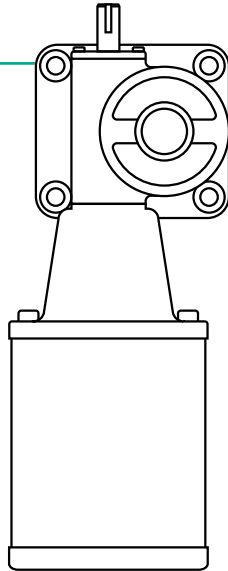

#### Direct Drives

- Stock AC Motor Mounts  
See page 179
- Servo Motor Adapters  
See page 178
- Custom Adapters

#### ComDRIVE®

**Self-contained actuators combine jack, gear reducer and motor in a single compact unit.**

- Machine Screw ComDRIVE®  
See pages 45-57
- Ball Screw ComDRIVE®  
See pages 102-117
- Electric Cylinder ComDRIVE®  
See pages 118-134

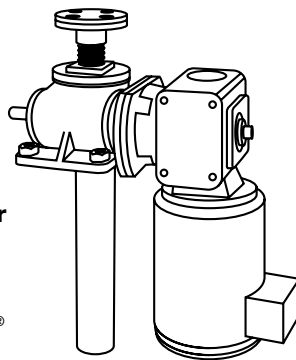

### MOTOR CONTROLS

#### Variable Speed Positioning System (VSPS)

- 10 Programmable Preset positions  
See page 193

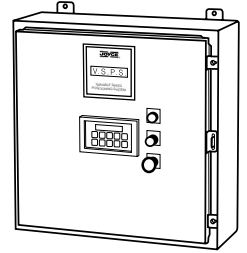

#### Custom Controls include Synchronized Systems, Positioning Systems, and Leveling Systems

Contact Joyce

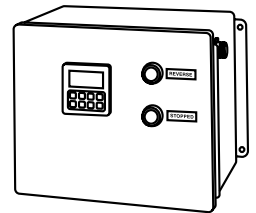

#### Motor Starters

- Momentary Contact Motor Starters  
See page 192

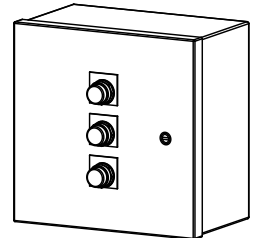

#### Actuator Controls

- 120 VAC - 120 VAC
- 120 VAC - 12 VDC
- 12 VDC - 12 VDC  
See page 194

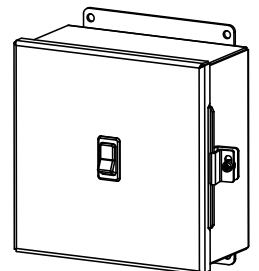

## 1. What is the difference between upright and inverted jack configurations?

The difference between an upright and an inverted jack is the location at which the lifting screw exits the jack relative to the jack base. For example, an upright jack's lifting screw exits the jack opposite the base. An inverted jack's lifting screw exits the jack on the same side as the base. The choice between inverted and upright jack is dependent upon the application.

Note: An upright jack mounted upside down is still referred to as an upright jack.

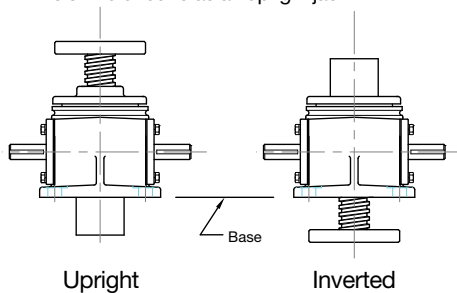

## 2. How can I determine worm shaft rotation extending the lifting screw?

Refer to the views of the standard jack with right hand screw threads below:

- For an Upright jack:  
CCW rotation of right input shaft extends the lifting screw.  
CW rotation of the left shaft extends lifting screw.
- For an Inverted jack:  
CW rotation of right input shaft extends lifting screw.  
CCW rotation of the left shaft extends lifting screw.

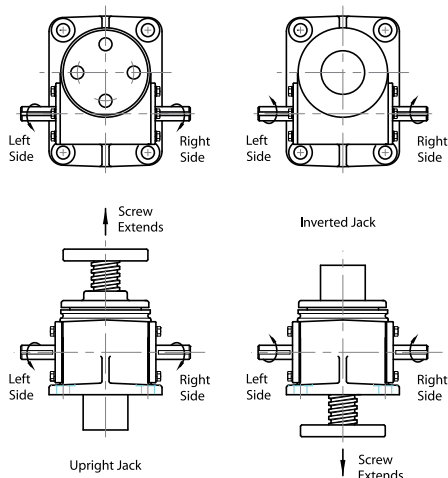

## 3. How is the linear travel speed calculated?

Each screw jack and actuator has an inherent number of input shaft turns per inch (TPI) of screw travel. TPI is the result of the jack's gear ratio divided by the lifting screw lead. The TPI can be found on jack specification pages at the beginning of many product sections. A model WJT242 has a TPI of 96. If 350 RPM is applied to the input shaft, the resultant linear speed of travel is  $350/96$  or 3.65 inches per minute.





## 4. Are screw jacks lubricated prior to shipment?

All Joyce machine screw jacks and ComDRIVES®, ball screw jacks and ComDRIVES®, bevel ball actuators, integrated actuators, and electric cylinders are lubricated with an extreme pressure NLGI grade #1 grease before leaving the factory.

Bevel gear jacks are lubricated with NLGI grade #1 grease and oil. The upper bearing and jackscrew are grease lubricated while the remaining internal components are oil lubricated. They are grease lubricated prior to shipment; however oil must be added to the unit prior to operation.

## 5. What are the standard end conditions for screw jack lifting screws?

The following standard end conditions are available on Joyce screw jacks:

- Type 1 plain turned end 
- Type 2 load pad with mounting holes 
- Type 3 male threaded end 
- Type 4 male clevis end 

Contact Joyce for information about custom end conditions.

## 6. How is the clevis, T4 end, positioned on a keyed jack?

- Standard clevis mounting position – the hole in the clevis end is parallel with the worm input shaft.
- Optional mounting position – the hole in the clevis end is perpendicular to the worm input shaft.

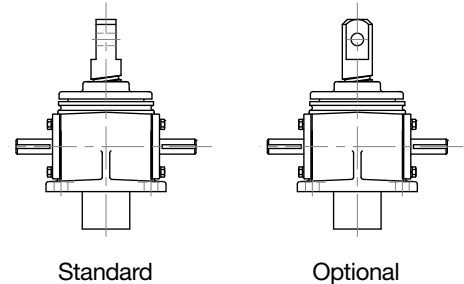

## 7. How is the load pad, T2 end, positioned on keyed jacks?

- Standard load pad mounting position – the holes on the load pad are on the jack centerlines.
- Optional load pad mounting position – the holes on the load pad end straddle the jack centerlines.

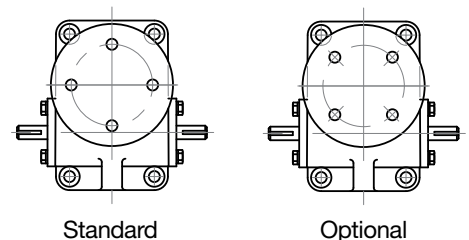



**8. Can I buy a jack with a clevis on both ends?** Yes. When freedom of movement in two axes is required, a double clevis jack may be specified.

- Double clevis jacks incorporate a clevis machined or pinned on the screw end and also a clevis welded to the protection tube.

Screw travel is limited. Contact sales@joycedayton.com for more information.

- Electric cylinders, integrated actuators, and linear actuators are also available with a clevis on both ends.

**9. What is meant by “self-locking”?**

Self-locking is a term used to describe jacks that require power to move in either direction. They hold their position when power to the system is off. See page 10 for more details.

**10. What if the jack is not self-locking?**

A brake is required on the input shaft of any jack that may lower under load (ball screw jacks, double-lead Acme screw jacks, integrated actuators, and electric cylinders that are more than 30% efficient). See page 10 for more details.

**11. How much side load can be placed on a screw jack?**

Standard jacks and actuators are not designed for dynamic side loads. The load must be positioned axially. Static side loads are limited. Contact sales@joycedayton.com for technical assistance. See page 10 for more details.

**12. How much backlash is in a machine screw jack?**

In machine screw jacks there are two types of backlash: worm to wormgear backlash (typically 8-15° worm rotation), and lifting screw to nut backlash, sometimes called endplay (up to 0.020 inches on new standard jacks). Refer to the JAX® Online browser-based software for information about specific jacks.

**13. Can I reduce machine screw backlash?**

Yes, screw backlash can be adjusted on translating and keyed style machine screw jacks via one of the following anti-backlash options: standard split-nut design; A90 external nut adjustment; or A95 design. See page 181.

**14. What is screw lead error?** The deviation from the mathematical lead expressed in inches per foot cumulative.

**15. What is the amount of lead error in a standard lifting screw?** Rolled Acme screws have up to .010 in/ft cumulative error, milled Acme screws have up to 0.003 in/ft cumulative error; and ball screws have up to 0.007 in/ft cumulative error. Contact Joyce for more information.

**16. Are Joyce/Dayton jacks and actuators user-serviceable?** The level to which products can be serviced in the field varies from product to product. Refer to the product Operation & Maintenance Manuals or contact Joyce for more information.

**17. What motor options are available?**

Motor options vary among product lines. Customers can use AC 3-phase, AC single-phase, DC motors, international voltage motors and others. Let us know your requirements.

**18. Are limit switches preset?** No.

- Shaft-mounted rotary cam limit switches must be set to the required positions during installation.
- Limit switches on linear actuators must be set after the actuators have been installed in order to tailor the stop position to the individual application.

**19. What do I need to consider when ordering a bellows boot to protect the lifting screw?**

- Closed height dimensions may increase when boots are added.
- The customer must specify boot collar diameter when ordering bellows boots for KFTN jacks.
- Zippered boots are also available.
- Special boot material is available.
- Horizontal screw applications may require boot guides.
- See pages 170-173

**20. Are jacks and actuators corrosion-resistant?** Stainless steel jacks are inherently corrosion resistant. All exposed surfaces are stainless steel and aluminum bronze. Most other jacks can be modified with special finishes, coatings, and seals. Contact Joyce with your requirements. See Finishes on page 182.

**21. What is a follower nut assembly and when is it helpful to have one?**

Follower nut assemblies allow customers to gauge the wear on the wormgear screw thread of translating jacks and on the traveling nut screw thread of KFTN jacks. This allows customers to replace the nut before its threads wear too thin to support the design load. These assemblies generally consist of a gear nut or traveling nut pinned to a second nut of dissimilar material. A preset gap separates the two nuts. As the wormgear or traveling nut threads wear, the preset gap narrows. The assembly is replaced when the gap measurement reaches the design limit. Follower nut assemblies are designed for specific applications. Contact Joyce for more information.

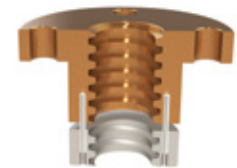

Versatile Joyce machine screw jacks lift and precisely position all kinds of loads from 250 pounds to 250 tons.

Upright or inverted, these precision jacks operate at full capacity whether the load is in tension or compression. WJ and RWJ series single lead jacks are self-locking under full lifting capacity. DWJ and DRWJ double lead series jacks offer increased travel speed.

Alloy steel input shafts, aluminum bronze wormgears and tapered roller or ball thrust bearings provide rugged reliability.

Double input shafts are standard. Single input shafts are available with right or left hand extension or additional length. Jacks are available with one of four standard end conditions or special ends to meet your requirements. All jack designs can be fitted with protective boots.

An optional anti-backlash feature (page 181) compensates for thread wear, assuring minimum play between lifting screw and wormgear for smooth, precise operation. Jacks equipped with the anti-backlash feature are rated at full capacity under static conditions. For anti-backlash jack capacity under dynamic conditions, please contact [sales@joycedayton.com](mailto:sales@joycedayton.com).

Joyce can customize machine screw jacks to meet your specifications.

# MACHINE SCREW JACKS

Joyce offers Machine Screw Jacks in several designs including:

- Translating
- Keyed for non-rotation
- Keyed for traveling nut (KFTN)
- Double clevis
- Trunnion

A guide for ordering is on pages 20 and 21.



# MACHINE SCREW JACKS ORDERING INFORMATION

Instructions: Select a model number from this chart.

Miniature	1-Ton	2-Ton	2-Ton Reverse Base	3-Ton	5-Ton	10-Ton	15-Ton	20-Ton
WJ250 WJ500* WJ1000	WJ51 WJ201	WJT62 WJT122 WJT242 WJT252	RWJT62 RWJT122 RWJT242 RWJT252	WJ63 WJ123 WJ243 WJ253	WJT65 WJT125 WJT245 WJT255	WJ810 WJ2410 WJ2510	WJ815 WJ2415 WJ2515	WJ820 WJ2420 WJ2520
		DWJ62* DWJ122* DWJ242*	DRWJ62* DRWJ122* DRWJ242*	DWJ63* DWJ123* DWJ243*	DWJ65* DWJ125* DWJ245*	DWJ810* DWJ2410*	DWJ815* DWJ2415*	DWJ820* DWJ2420*
25-Ton	30-Ton	35-Ton	50-Ton	50-Ton Reverse Base	75-Ton	100-Ton	150-Ton	250-Ton
WJ1125 WJ3225	WJ1130 WJ3230	WJ1135 WJ3235	WJT1150 WJT3250	RWJT1150 RWJT3250	WJ1175 WJ3275	WJ12100 WJ36100	WJ12150 WJ36150	WJ50250
DWJ1125* DWJ3225*	DWJ1130* DWJ3230*							

**Important Note:** \*Not self-locking, may lower under load. Brake motors or external locking systems are recommended.

**D:** Double Lead Screw

**R:** Reverse Base Jack, (only available on 2-ton and 50-ton jacks).

## Sample Part Number: WJT65U1N-18.50-STDX-STDX-B

### Jack Configuration

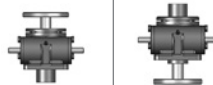

**U=Upright**    **I=Inverted**

### End Conditions

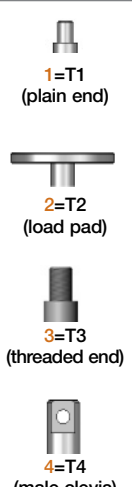

**1=T1**  
(plain end)

**2=T2**  
(load pad)

**3=T3**  
(threaded end)

**4=T4**  
(male clevis)

### Left Side Shaft Code

(see below)



**XXXX=Remove**  
**STDX=Standard**  
**CUST=Custom**

For optional shaft codes, see page 21.

### Right Side Shaft Code

(see below)

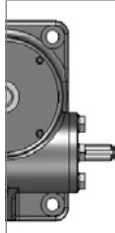

**XXXX=Remove**  
**STDX=Standard**  
**CUST=Custom**

For optional shaft codes, see page 21.

### Additional Options\*

**X=Standard Jack**, no additional options

**S=Additional Specification Required** (comment as necessary)

**Anti-Backlash**  
p. 181

**A=Split Nut**  
**A90=A90 Design**  
**A95=A95 Design**

**Protective Boots**  
pp. 170-173

**B=Protective Boot**  
**D=Dual Protective Boot**

**Finishes** p. 182

**F1=Do Not Paint**  
**F2=Epoxy Paint**  
**F3=Outdoor Paint Process**

**Motor Options**

**M1=Less Motor**  
**M2=Brake Motor**  
**M3=Single Phase Motor (120VAC)**  
**M4=50Hz Motor**  
**M5=Special Motor**

**Grease/Seals**

**H1=High Temperature Operation**  
**H2=Food Grade**

**Screw Stops**

**ST0=Extending**  
**ST1=Retracting**  
**ST2=Both**

\* Specify as many options as needed

### Machine Screw Jack Rise

Rise is travel expressed in inches and not the actual screw length.

### Jack Designs



**S=Translating**    **K=Keyed for Non Rotation**    **N=Traveling Nut**    **D=Double Clevis**    **A=KFTN Trunnion\***  
**T=Trunnion\***

\*Standard trunnion mounts available on 2-ton through 20-ton jacks. (See page 183)

# MACHINE SCREW JACKS SHAFT CODES

**Instructions:** Select the appropriate shaft codes for both right and left hand shafts. One shaft code must be specified for each side of the jack.

**Screw Stops (p. 10) and Boots (pp. 170-173)**

Screw stops are optional on machine screw jacks. When specified, the closed height of the jack and/or the protection tube length may be increased.

When boots are added to machine screw jacks, the closed height of the jack may be increased.

**Mechanical Counters (p. 180)**

**CNT0**=0.001" Increments

Note: Contact Joyce for availability and options.



**Hand Wheels (p. 180)**

**HW04**=4" dia  
**HW06**=6" dia  
**HW08**=8" dia  
**HW10**=10" dia  
**HW12**=12" dia



Recommended for self-locking jacks only.

**Geared Potentiometers (p. 175)**

**POTA**=0-10V  
**POTB**=4-20mA  
**POTC**=0-10V w/2 switches  
**POTD**=4-20mA w/2 switches

IP65 rated enclosures



**Encoders (pp. 176-177)**

**ENCA**=Absolute Encoder 0-10 VDC, programmable  
**ENCB**=Absolute Encoder 4-20mA, programmable  
**ENCC**=Absolute Encoder CAN Open  
**ENCD**=Absolute Encoder SSI  
**ENCS**=Stainless Steel Incremental Encoder 1024 PPR  
**ENCX**=Incremental Encoder 200 PPR  
**ENCY**=Incremental Encoder 1024 PPR



**Motors for Systems and Direct Drives (pp. 178-179)**

- All standard motors are 3-phase, 208-230/460 VAC or 230/460 VAC. Other motor options are available. Specify the appropriate motor size from the chart on the right.
- Refer to the "Additional Options" chart on the preceding page as needed.
- Brake motors (M2) are recommended for jacks that are not self-locking, and jacks with double lead screws.
- If the motor frequency will be varied to provide a "soft" start an inverter duty motor may be required.

**Motors**

Size	Code
1/4 HP	K
1/3 HP	A
1/2 HP	B
3/4 HP	C
1 HP	D
1-1/2 HP	E
2 HP	F
3 HP	L
5 HP	G
7-1/2 HP	H
10 HP	I
15 HP	J

**Motor Mounts (pp. 178-179)**

Ordering Example:

**MMA A**

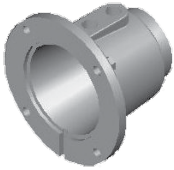

**MMA**=56C Motor code from chart at left  
**MMB**=140TC For servo motor mounts see p. 178  
**MMC**=180TC  
**MMD**=210TC

Standard motor adapters are aluminum.

**Mechanical Limit Switches (p. 174)**

Ordering Example: **LA13**

Models		Number of DPDT Switches (see p. 174)	Available Positions							
Model	Code		1	2*	3	4	5	6*	7	8
LS7-402	LI	NOTE: Will always be 0 for LS7 models								
LS8-402	LA									
LS8-404	LB									

Left Side Shaft Options  
Right Side Shaft Options

\*2, 3, 5, 10, 15, and 20 ton jacks are available with positions #1, #3, and #5  
 \*25, 30, 35, 50, 75, 100, and 150 ton jacks are available with positions #1, #4, #7, and #8  
 \*These positions are not standard. Contact Joyce with your requirements.

# MACHINE SCREW JACKS SPECIFICATIONS

Model	Capacity	Screw Diameter (Inches)	Thread Pitch/Lead	Worm Gear Ratio	Worm Shaft Turns for 1" Travel	Tare Torque (Inch Lbs.)	Starting Torque (Inch Lbs.)	Operating Torque (Inch Lbs.)	Efficiency Rating % Approx.	Screw Torque (Inch Lbs.)	Basic Jack Weight (Lbs.)	Jack Weight per Inch Travel (Lbs.)					
WJ250	250 lbs.	1/2	.125 pitch STUB ACME	5:1	40	1	.025W*	.018W* @ 500 RPM	23.0	.050W*	1.2	0.1					
WJ500	500 lbs.	5/8	.125 pitch .250 lead STUB ACME	5:1	20	1	.041W*	.030W* @ 500 RPM	27.2	.079W*	1.3	0.1					
WJ1000	1,000 lbs.	5/8	.125 pitch STUB ACME	5:1	40	1	.030W*	.021W* @ 500 RPM	19.9	.059W*	1.3	0.1					
WJ51	1 ton	3/4	.200 pitch ACME 2C	5:1	25	3	.038W*	.026W* @ 500 RPM	25.0	.075W*	6	0.3					
WJ201				20:1	100		.017W*	.009W* @ 500 RPM	15.9								
(R)WJT62	2 ton	1	.250 pitch ACME 2C	6:1	24	4	.041W*	.028W* @ 500 RPM	24.2	.098W*	15	0.3					
(R)WJT122				12:1	48		.025W*	.015W* @ 500 RPM	22.0								
(R)WJT242				24:1	96		.018W*	.009W* @ 500 RPM	18.3								
(R)WJT252				25:1	100		.015W*	.0085W* @ 500 RPM	17.0								
D(R)WJ62			6:1	12	.250 pitch .500 lead ACME 2C		12:1	24	4	.057W*			.039W* @ 500 RPM	33.7	.139W*	15	0.3
D(R)WJ122			12:1	24						.035W*			.022W* @ 500 RPM	30.5			
D(R)WJ242			24:1	48						.025W*			.013W* @ 500 RPM	25.4			
WJ63	3 ton	1	.250 pitch ACME 2C	6:1	24	6	.040W*	.029W* @ 500 RPM	24.3	.098W*	17	0.4					
WJ123				12:1	48		.025W*	.016W* @ 500 RPM	22.2								
WJ243				24:1	96		.017W*	.009W* @ 500 RPM	18.5								
WJ253				25:1	100		.0155W*	.009W* @ 500 RPM	17.8								
DWJ63			6:1	12	.250 pitch .500 lead ACME 2C		12:1	24	6	.055W*			.041W* @ 500 RPM	33.8	.139W*	17	0.4
DWJ123			12:1	24						.034W*			.022W* @ 500 RPM	30.7			
DWJ243			24:1	48						.024W*			.013W* @ 500 RPM	25.6			
WJT65	5 ton	1 1/2	.375 pitch STUB ACME	6:1	16	10	.065W*	.044W* @ 300 RPM	23.0	.151W*	32	0.7					
WJT125				12:1	32		.041W*	.025W* @ 300 RPM	20.6								
WJT245				24:1	64		.029W*	.015W* @ 300 RPM	16.7								
WJT255			25:1	100	.250 pitch ACME 2C		12:1	24	10	.022W*			.011W* @ 300 RPM	13.4	.131W*	32	0.7
DWJ65			6:1	12						.072W*			.050W* @ 300 RPM	26.8			
DWJ125			12:1	24						.045W*			.028W* @ 300 RPM	23.9			
DWJ245			24:1	48						.033W*			.017W* @ 300 RPM	19.6			
WJ810	10 ton	2	.500 pitch ACME 2C	8:1	16	20	.061W*	.043W* @ 200 RPM	23.1	.195W*	43	1.3					
WJ2410				24:1	48		.030W*	.018W* @ 200 RPM	18.8								
WJ2510			25:1	100	.250 pitch ACME 2C		8:1	12	20	.024W*			.014W* @ 200 RPM	11.3	.161W*	43	1.3
DWJ810			8:1	12						.070W*			.062W* @ 200 RPM	31.9			
DWJ2410			24:1	36						.333 pitch .666 lead ACME 2C			24:1	36			

**Important Note:** Series DWJ double lead screw jacks and WJ500 screw jacks are not self-locking. Brake motors or external locking systems are recommended.

(R): Reverse Base Jack.

\*W: Load in pounds.

**Tare Torque:** Initial torque to overcome seal and normal assembly drag. This value must be added to starting torque or operating torque values.

**Starting Torque:** Torque value required to start moving the rated load (dissipates to operating torque values once the load begins moving).

**Operating Torque:** Torque required to continuously raise a given load at the input RPM listed.

**Note:** If your actual input RPM is 20% higher or lower than the listed RPM, please refer to JAX® Online to determine actual torque values at your RPM.

**Screw Torque:** Torque required to resist screw rotation (Translating Design Jacks) and traveling nut rotation (Keyed for Traveling Nut Design Jacks).

**Lead:** The distance traveled axially in one rotation of the lifting screw.

**Pitch:** The distance from a point on a screw thread to a corresponding point on the next thread, measured axially.

**Note:** This chart is provided for reference only. For specific information such as column loading, allowable continuous travel and other performance factors please refer to JAX® Online software or contact Joyce.

# MACHINE SCREW JACKS SPECIFICATIONS

Model	Capacity	Screw Diameter (Inches)	Thread Pitch/Lead	Worm Gear Ratio	Worm Shaft Turns for 1" Travel	Tare Torque (Inch Lbs.)	Starting Torque (Inch Lbs.)	Operating Torque (Inch Lbs.)	Efficiency Rating % Approx	Screw Torque (Inch Lbs.)	Basic Jack Weight (Lbs.)	Jack Weight per Inch Travel (Lbs.)
WJ815	15 ton	2 1/4	.500 pitch ACME 2C	8:1	16	30	.069W*	.047W* @ 200 RPM	21.1	.210W*	59	1.4
WJ2415				24:1	48		.036W*	.020W* @ 200 RPM	16.6			
WJ2515			25:1	100	.026W*		.015W* @ 200 RPM	10.2				
DWJ815		2 1/4	.333 pitch .666 lead ACME 2C	8:1	12		.079W*	.058W* @ 200 RPM	34.4	.244W*		
DWJ2415				24:1	36		.041W*	.025W* @ 200 RPM	27.0			
WJ820	20 ton	2 1/2	.500 pitch ACME 2C	8:1	16	40	.075W*	.051W* @ 200 RPM	19.6	.227W*	77	1.9
WJ2420				24:1	48		.039W*	.022W* @ 200 RPM	15.4			
WJ2520			25:1	100	.029W*		.016W* @ 200 RPM	9.4				
DWJ820		2 1/2	.375 pitch .750 lead ACME 2C	8:1	10.67		.088W*	.061W* @ 200 RPM	24.5	.272W*		
DWJ2420				24:1	32		.046W*	.026W* @ 200 RPM	19.3			
WJ1125	25 ton	3 3/8	.666 pitch Stub ACME	11:1	16	50	.088W*	.055W* @ 200 RPM	18.3	.313W*	164	3.1
WJ3225				32:1	48		.053W*	.025W* @ 200 RPM	13.5			
DWJ1125		3 3/8	.562 pitch 1.125 lead ACME 2C	11:1	9.5		.106W*	.067W* @ 200 RPM	25.1	.384W*		
DWJ3225				32:1	28.5		.063W*	.030W* @ 200 RPM	18.6			
WJ1130	30 ton	3 1/2	.666 pitch ACME 2C	11:1	16	60	.088W*	.055W* @ 200 RPM	18.3	.313W*	164	3.0
WJ3230				32:1	48		.052W*	.025W* @ 200 RPM	13.5			
DWJ1130		3 1/2	.5625 pitch 1.125 lead ACME 2C	11:1	9.5		.107W*	.067W* @ 200 RPM	25.1	.384W*		
DWJ3230				32:1	28.5		.064W*	.030W* @ 200 RPM	18.6			
WJ1135	35 ton	3 3/4	.666 pitch ACME 2C	11:1	16	70	.093W*	.057W* @ 200 RPM	17.4	.328W*	240	3.4
WJ3235				32:1	48		.055W*	.026W* @ 200 RPM	12.9			
(R)WJT1150	50 ton	4 1/2	.666 pitch ACME 2C	11:1	16	100	.095W*	.063W* @ 150 RPM	15.8	.378W*	387	6.1
(R)WJT3250				32:1	48		.050W*	.027W* @ 150 RPM	12.4			
WJ1175	75 ton	5	.666 pitch ACME 2C	11:1	16	155	.107W*	.067W* @ 150 RPM	14.8	.418W*	610	6.5
WJ3275				32:1	48		.056W*	.028W* @ 150 RPM	11.7			
WJ12100	100 ton	6	.750 pitch ACME 2C	12:1	16	205	.112W*	.072W* @ 90 RPM	13.9	.495W*	1010	10.0
WJ36100				36:1	48		.059W*	.031W* @ 90 RPM	10.8			
WJ12150	150 ton	7	1.00 pitch ACME 2C	12:1	12	300	.134W*	.084W* @ 90 RPM	15.7	.595W*	1350	12.2
WJ36150				36:1	36		.070W*	.037W* @ 90 RPM	12.1			
WJ50250	250 ton	9	1.00 pitch ACME 2C	50:1	50	500		.036W* @ 60 RPM	8.8	.711W*	3415	21.0

**Important Note:** Series DWJ double lead screw jacks and WJ500 screw jacks are not self-locking. Brake motors or external locking systems are recommended.

(R): Reverse Base Jack.

\*W: Load in pounds.

**Tare Torque:** Initial torque to overcome seal and normal assembly drag. This value must be added to starting torque or operating torque values.

**Starting Torque:** Torque value required to start moving the rated load (dissipates to operating torque values once the load begins moving).

**Operating Torque:** Torque required to continuously raise a given load at the input RPM listed.

**Note:** If your actual input RPM is 20% higher or lower than the listed RPM, please refer to JAX® Online to determine actual torque values at your RPM.

**Screw Torque:** Torque required to resist screw rotation (Translating Design Jacks) and traveling nut rotation (Keyed for Traveling Nut Design Jacks).

**Lead:** The distance traveled axially in one rotation of the lifting screw.

**Pitch:** The distance from a point on a screw thread to a corresponding point on the next thread, measured axially.

**Note:** This chart is provided for reference only. For specific information such as column loading, allowable continuous travel and other performance factors please refer to JAX® Online software or contact Joyce.

# MACHINE SCREW JACKS COLUMN LOADING

Machine Screw Jack Column Loading Chart

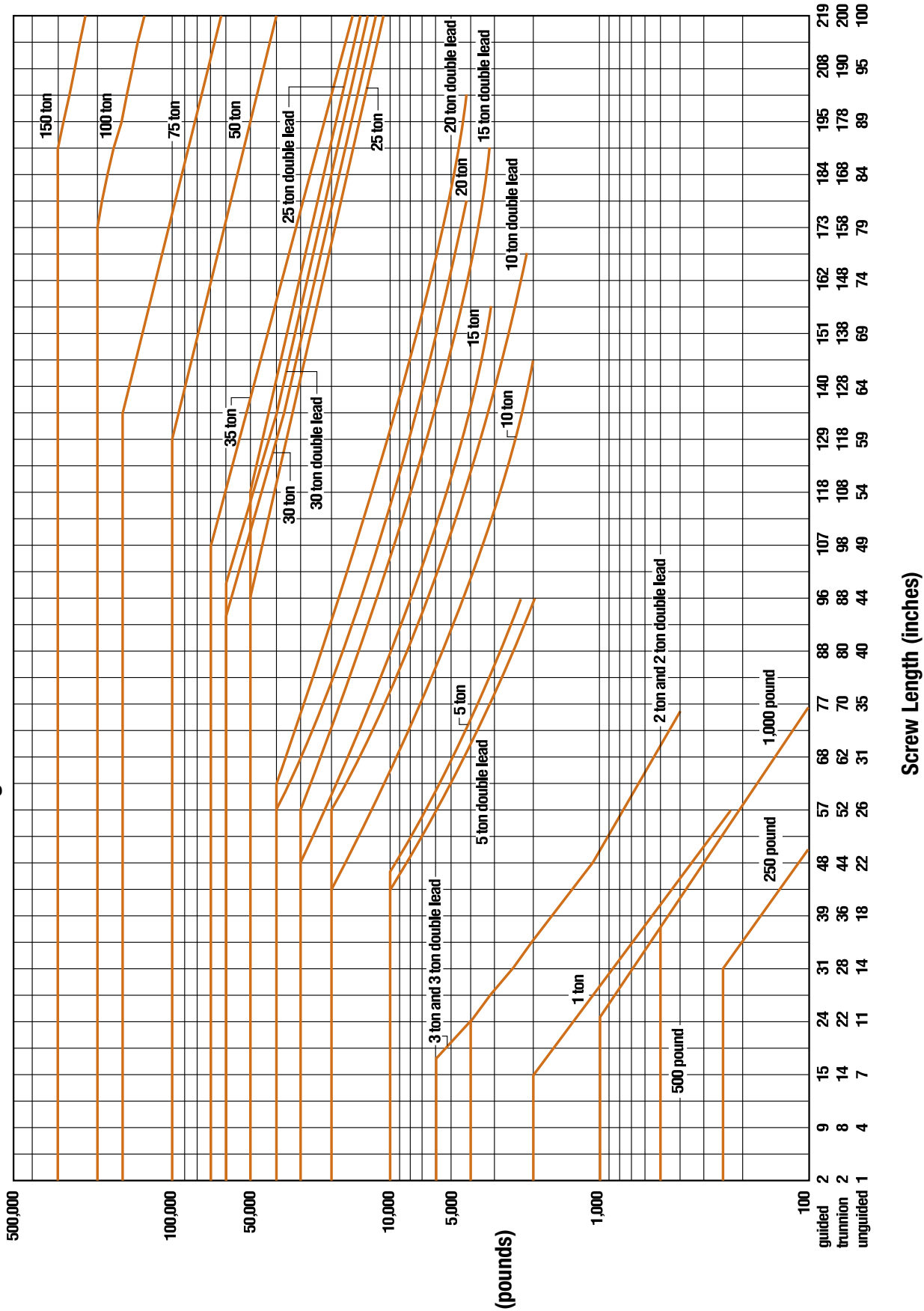

This chart includes a 2:1 Factor-of-Safety based on the Euler-Johnson equation for column loading (Oberg, Erik et al: Machinery's Handbook, 24th Edition, c. 1992 Industrial Press Inc.) The horizontal portion of each line represents the jack's maximum dynamic capacity. Under static conditions, these lines can be exceeded. Please contact factory for assistance.



# MACHINE SCREW JACKS

250 POUND - 1/2" SCREW

WJ 250

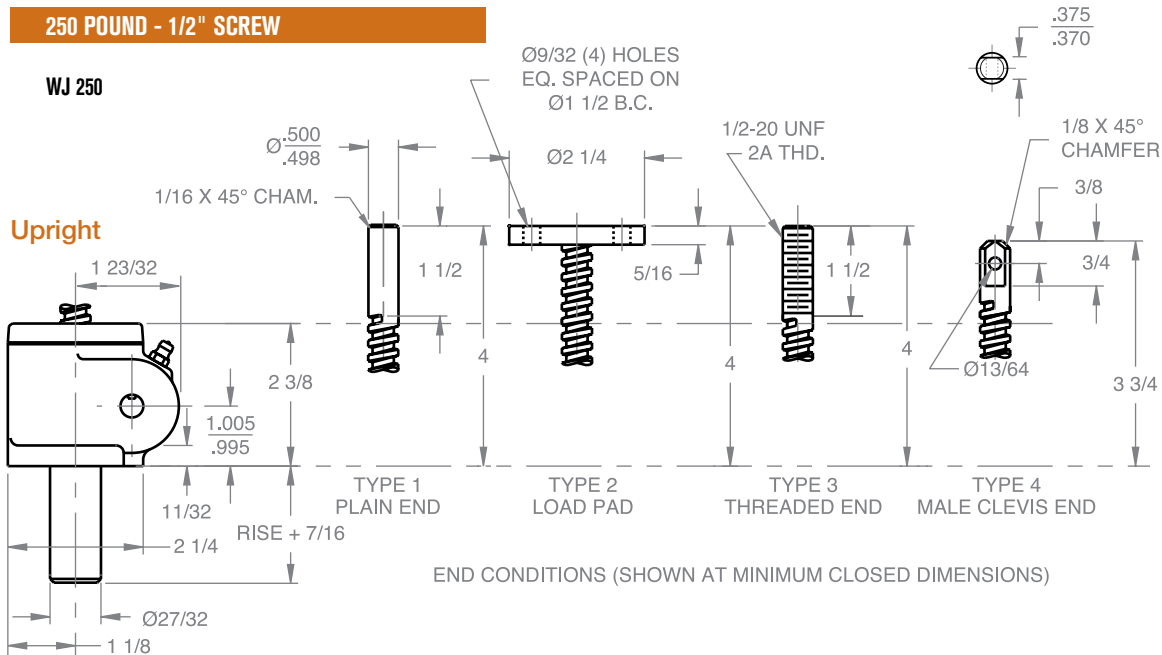

**Upright  
traveling nut**

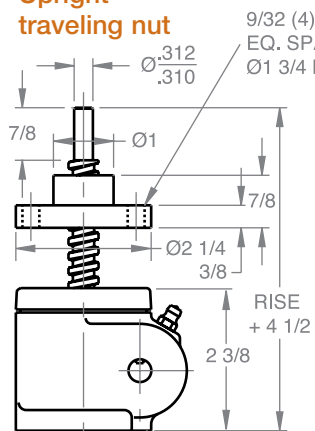

**Typical Plan View**

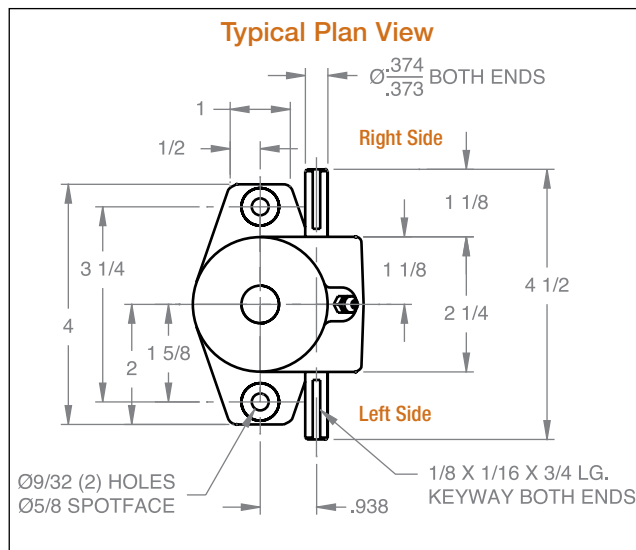

**Inverted  
traveling nut**

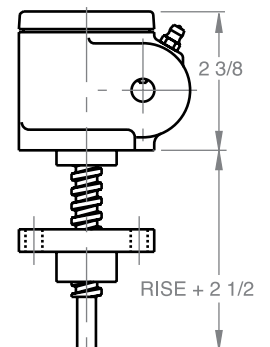

**Inverted**

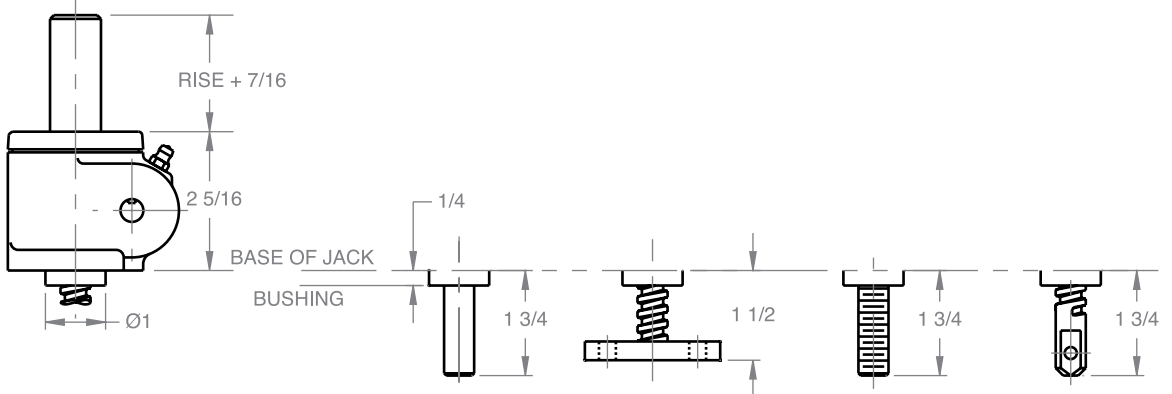

Material Notes: Housing and protection tube are aluminum. Lifting screw is 304 S.S., Input shaft (worm) is 416 S.S.

Note: Drawings are artist's conception — not for certification; dimensions are subject to change without notice.

# MACHINE SCREW JACKS

500 POUND - 5/8" SCREW

WJ 500

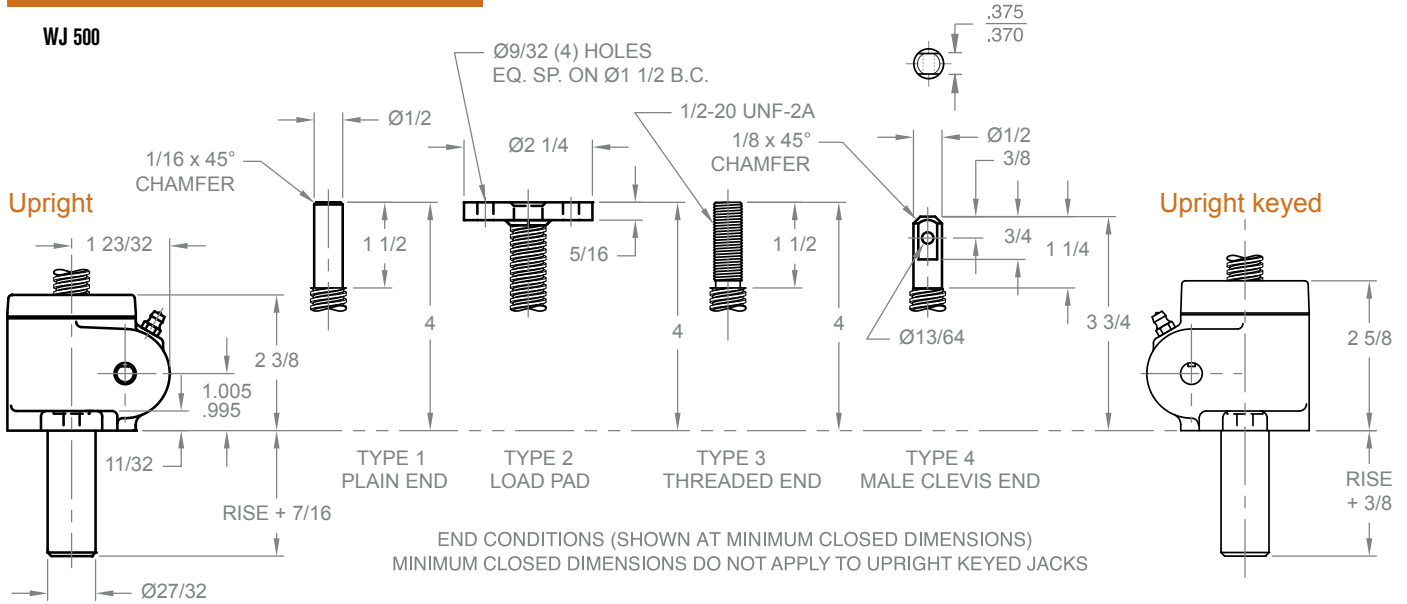

**Upright traveling nut**

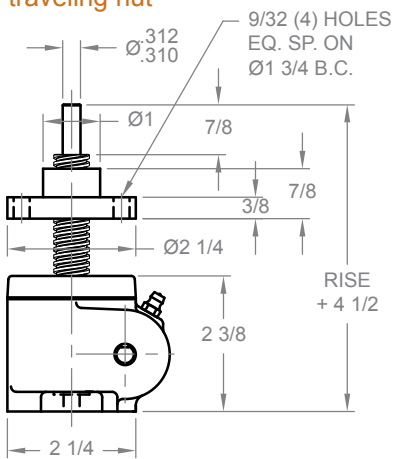

**Typical Plan View**

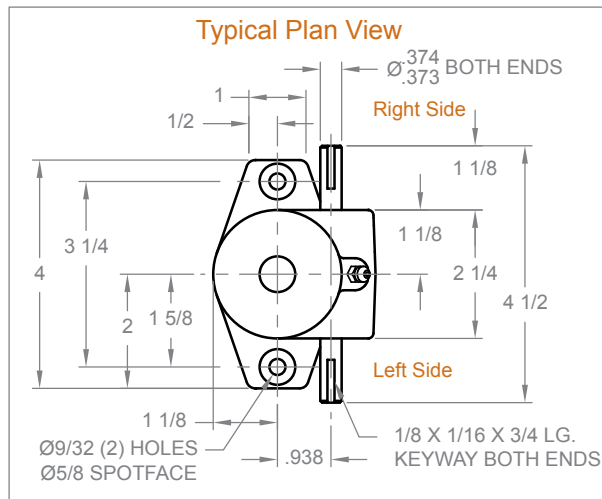

**Inverted traveling nut**

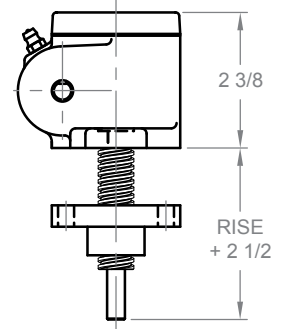

**Inverted**

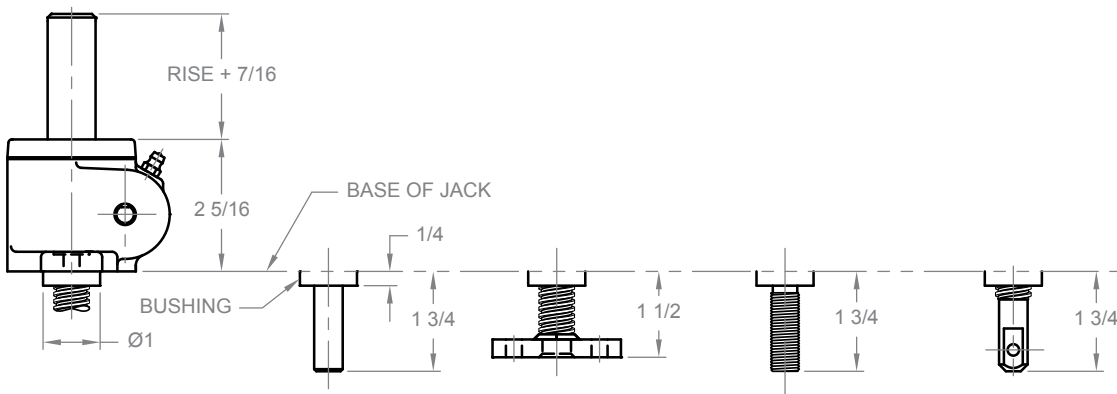

**Inverted keyed**

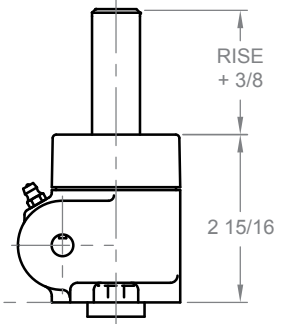

Material Notes: Housing and protection tube are aluminum. Lifting screw is 304 S.S. Input shaft (worm) is 416 S.S.

Note: Drawings are artist's conception - not for certification; dimensions are subject to change without notice.

# MACHINE SCREW JACKS

1000 POUND - 5/8" SCREW

WJ 1000

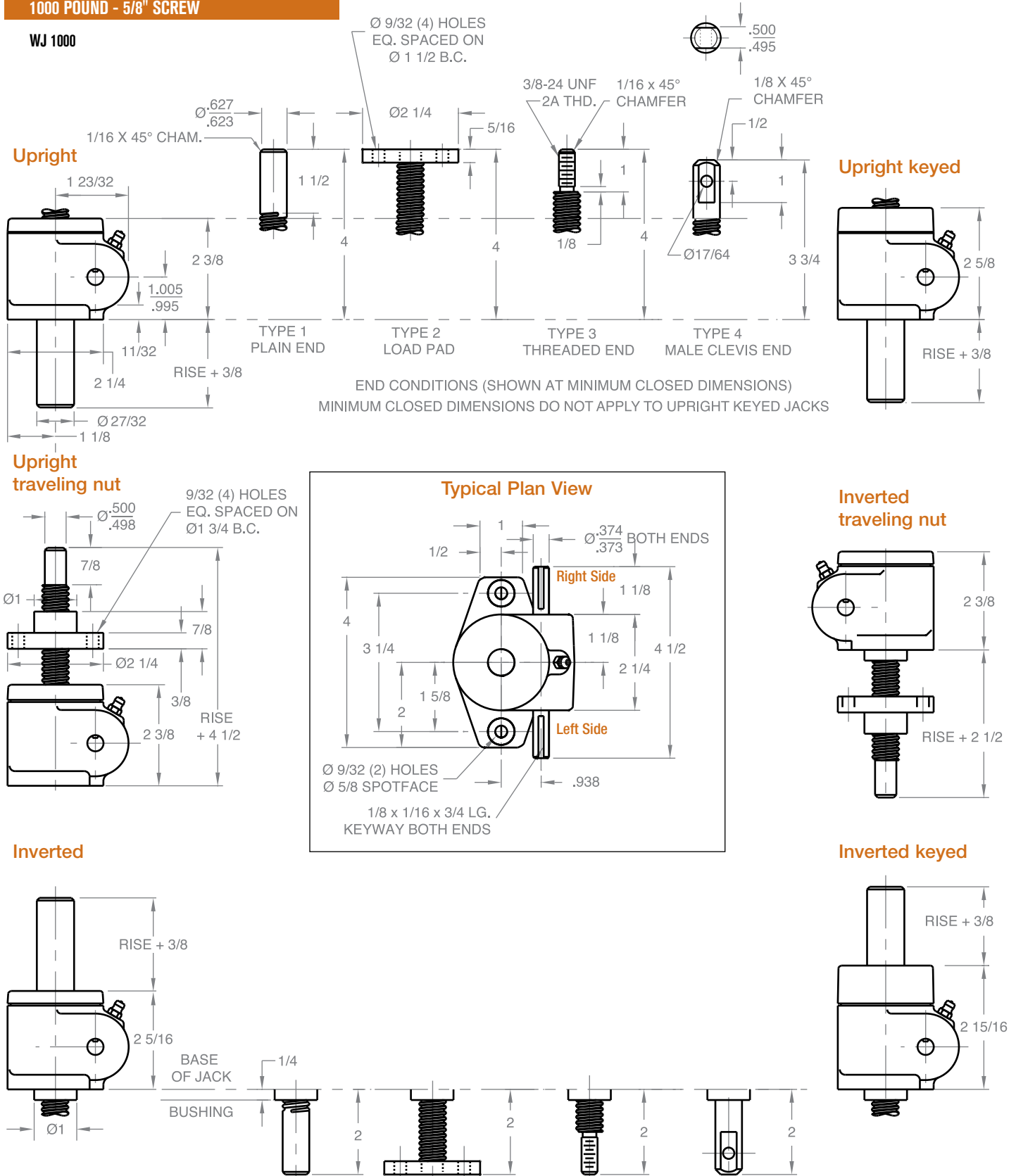

Material Notes: Housing and protection tube are aluminum. Lifting screw is 304 S.S. Input shaft (worm) is 416 S.S.

Note: Drawings are artist's conception — not for certification; dimensions are subject to change without notice.

# MACHINE SCREW JACKS

1 TON - 3/4" SCREW

WJ 51 / WJ 201

Upright

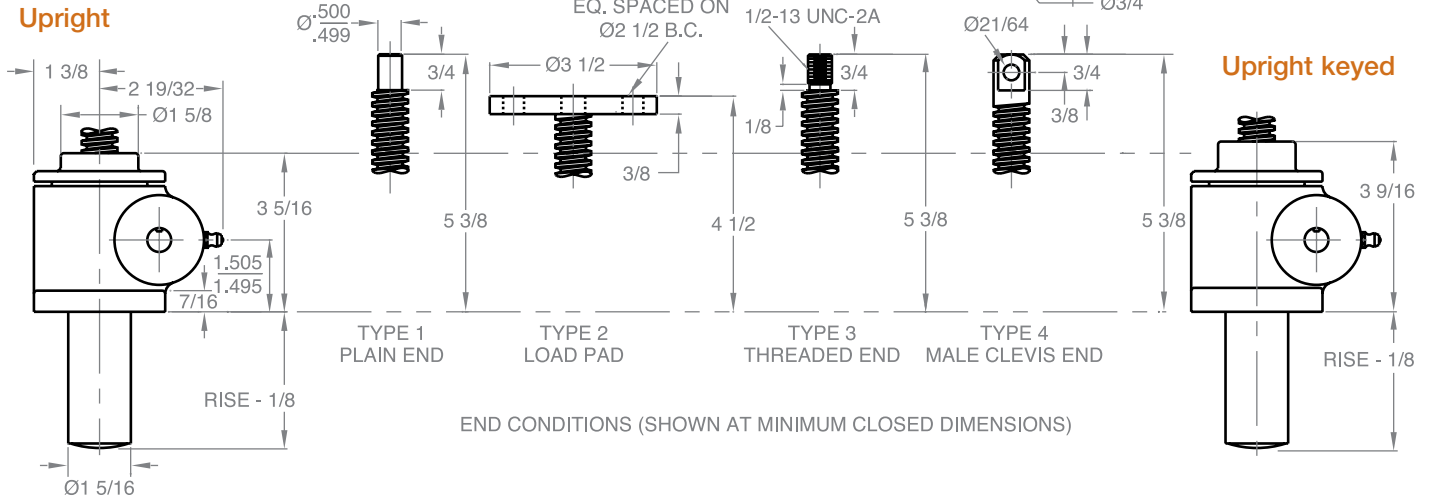

Upright keyed

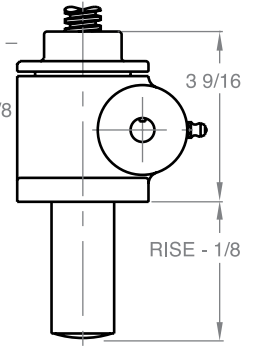

Upright traveling nut

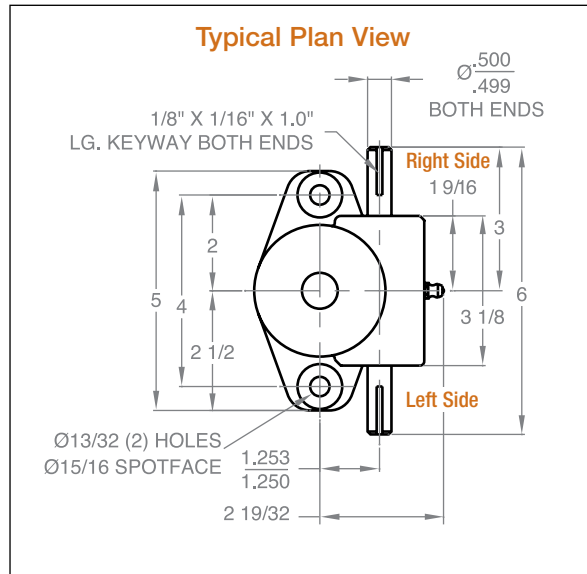
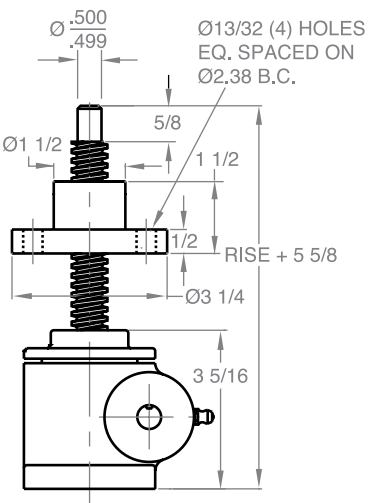

Inverted traveling nut

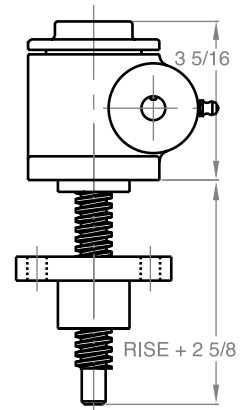

Inverted

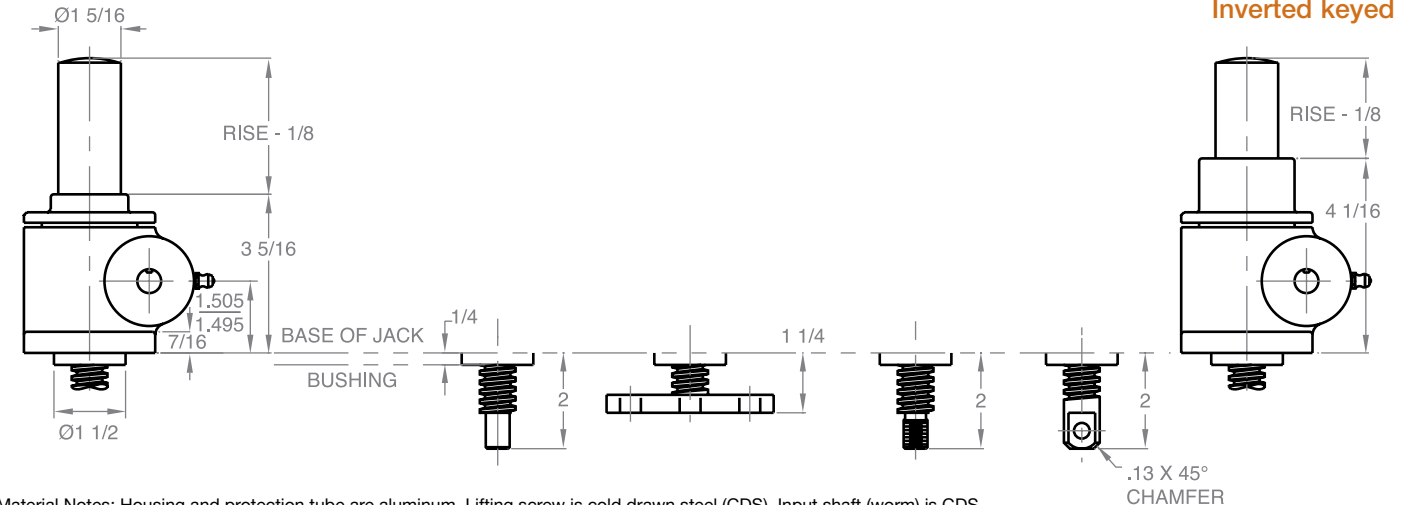

Inverted keyed

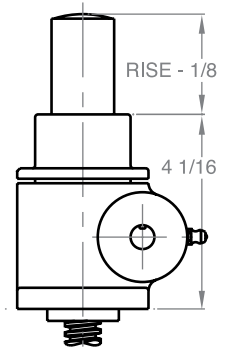

Material Notes: Housing and protection tube are aluminum. Lifting screw is cold drawn steel (CDS). Input shaft (worm) is CDS.

Note: Drawings are artist's conception — not for certification; dimensions are subject to change without notice.

# MACHINE SCREW JACKS

## 2 TON - 1" SCREW

WJT 62 / DWJ 62  
 WJT 122 / DWJ 122  
 WJT 242 / DWJ 242  
 WJT 252

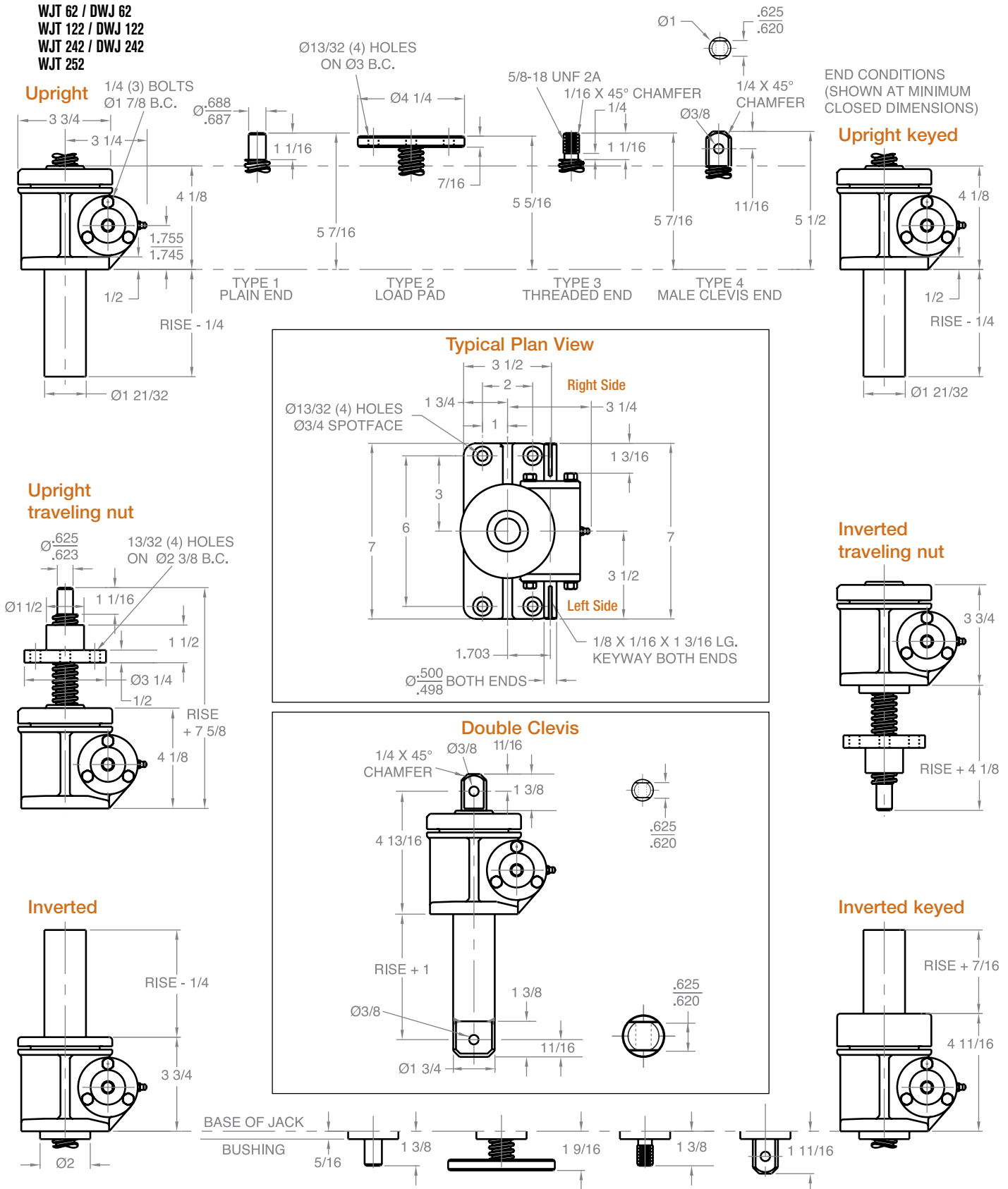

Note: Drawings are artist's conception — not for certification; dimensions are subject to change without notice.

# MACHINE SCREW JACKS

## 2 TON REVERSE BASE - 1" SCREW

RWJT 62 / DRWJ 62  
 RWJT 122 / DRWJ 122  
 RWJT 242 / DRWJ 242  
 RWJT 252

### Upright

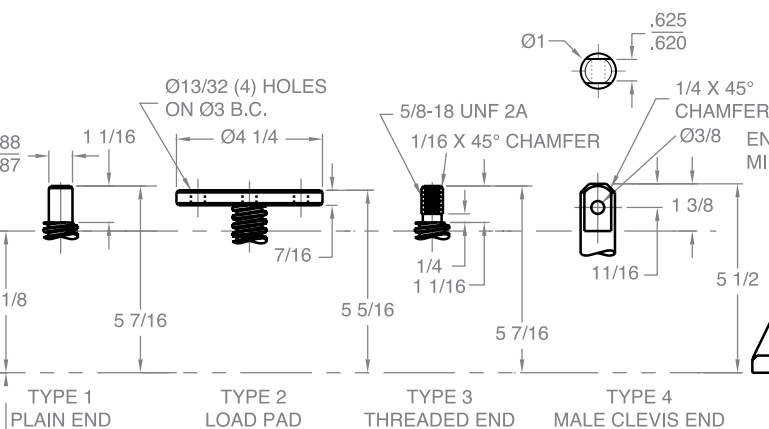
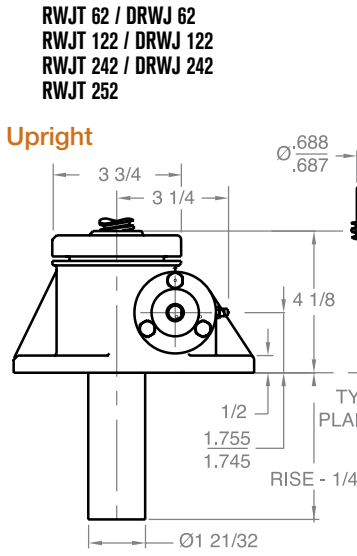

### Upright keyed

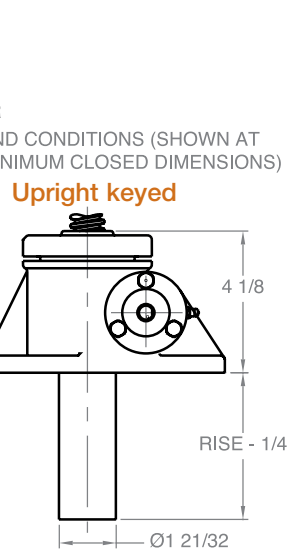

### Upright traveling nut

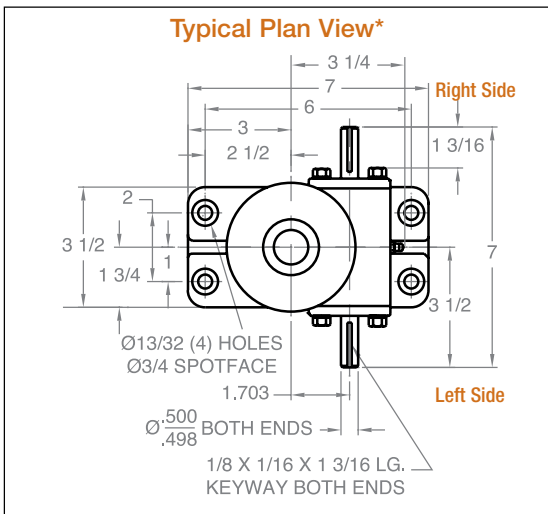
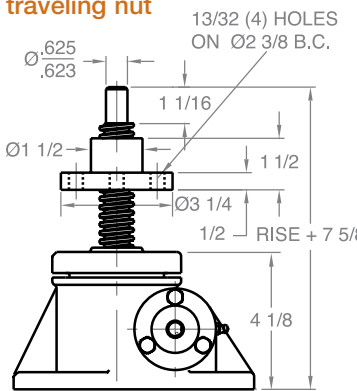

### Inverted traveling nut

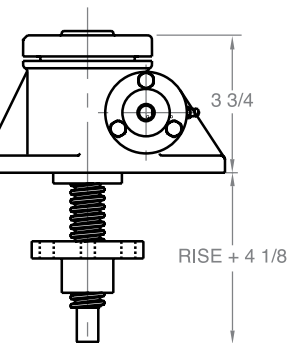

### Inverted

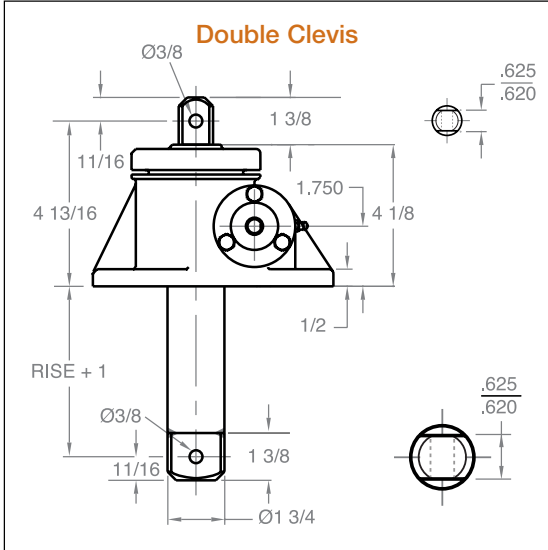
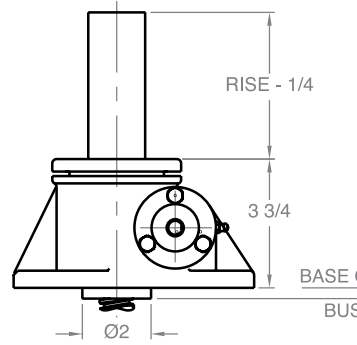

### Inverted keyed

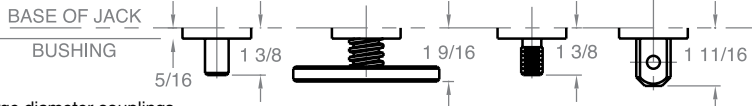
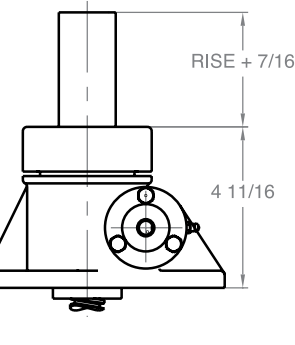

\*Ideal for DD motor mounts or for large diameter couplings.

Note: Drawings are artist's conception — not for certification; dimensions are subject to change without notice.

# MACHINE SCREW JACKS

## 3 TON - 1" SCREW

WJ 63 / WJ 123 / WJ 243 / WJ 253  
DWJ 63 / DWJ 123 / DWJ 243

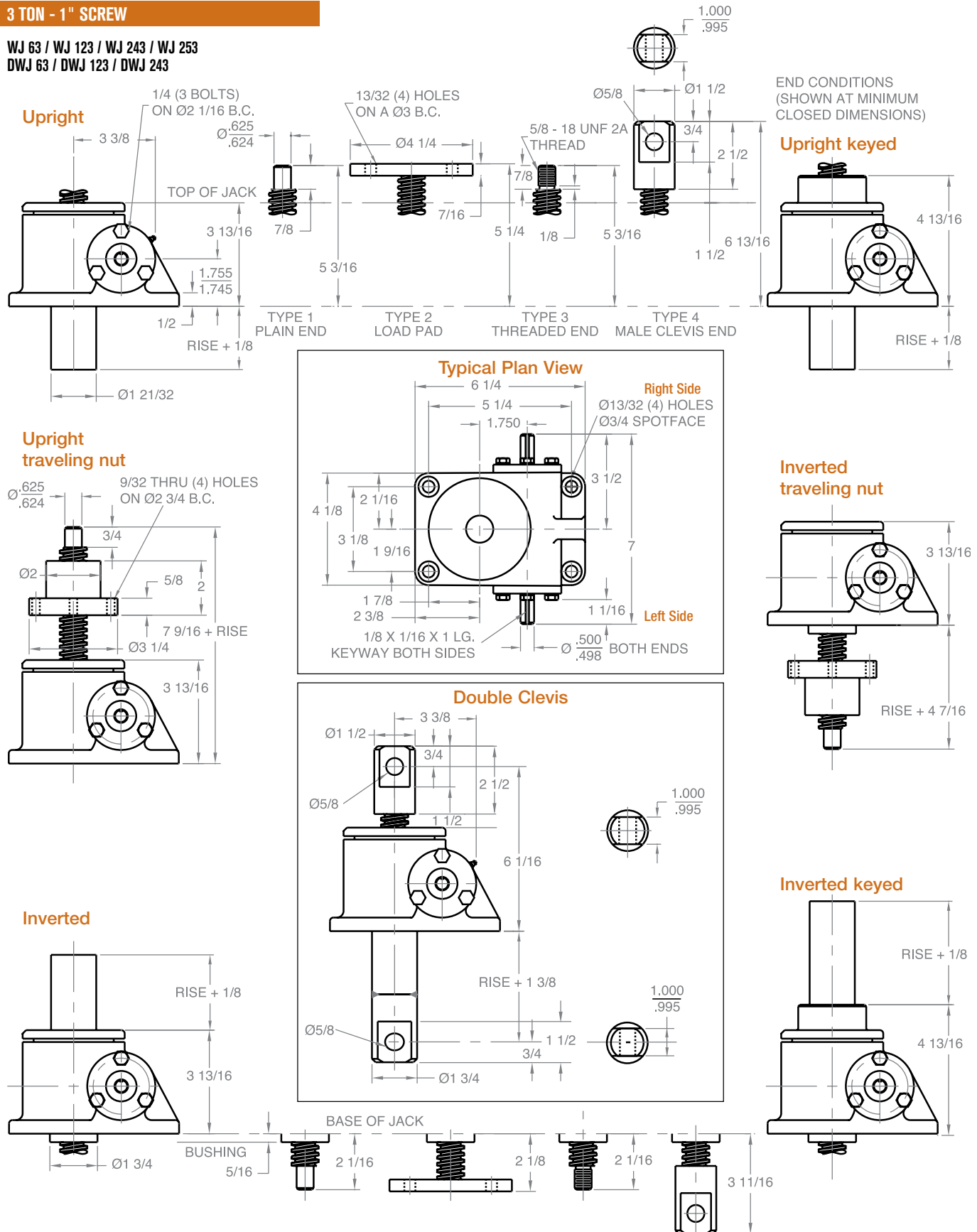

Note: Drawings are artist's conception — not for certification; dimensions are subject to change without notice. Minimum closed dimensions do not apply to upright keyed jacks.

# MACHINE SCREW JACKS

## 5 TON - 1 1/2" SCREW

WJT 65 / DWJ 65  
 WJT 125 / DWJ 125  
 WJT 245 / DWJ 245  
 WJT 255

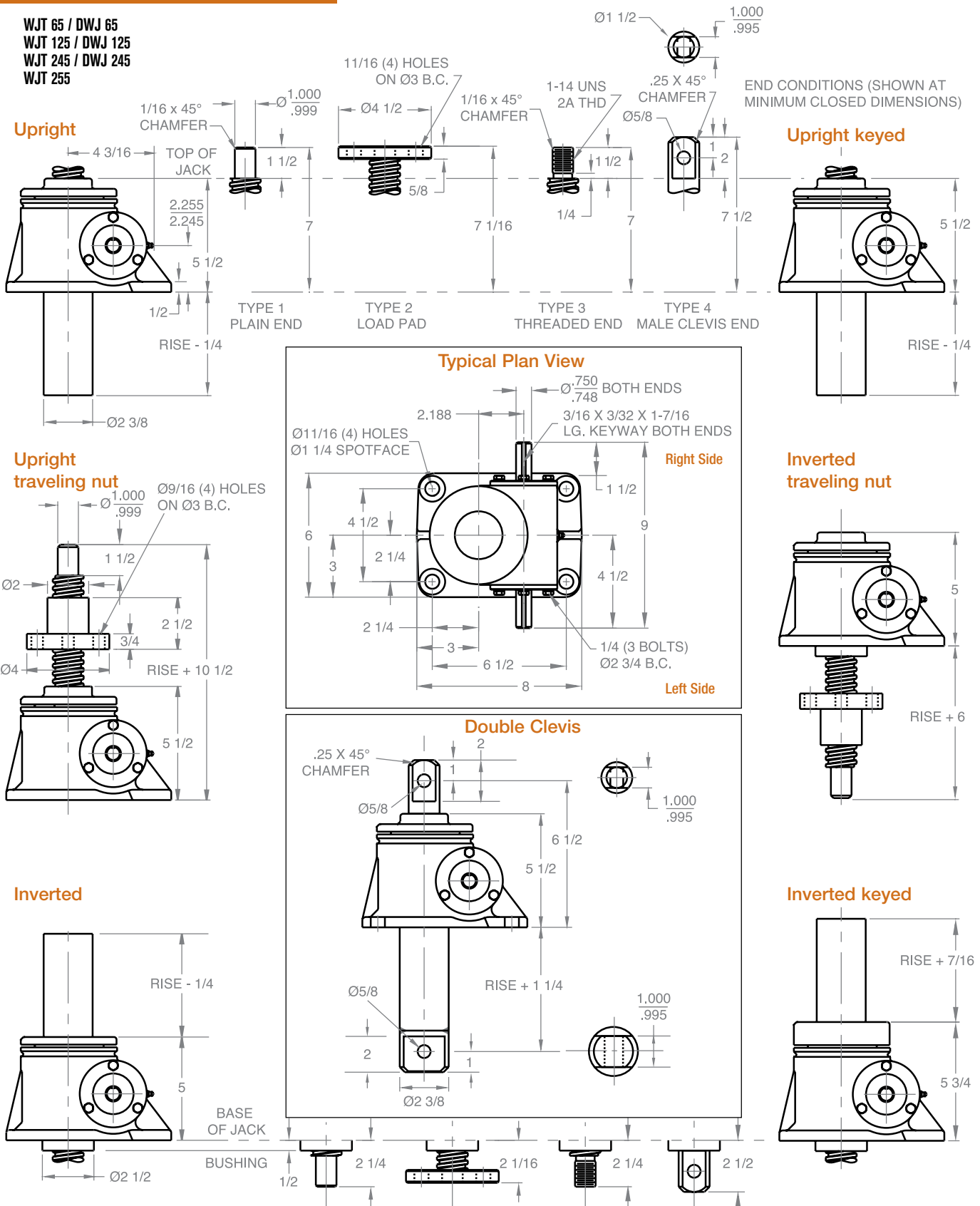

Note: Drawings are artist's conception — not for certification; dimensions are subject to change without notice.



# MACHINE SCREW JACKS

## 10 TON - 2" SCREW

WJ 810 / DWJ 810  
WJ 2410 / DWJ 2410  
WJ 2510

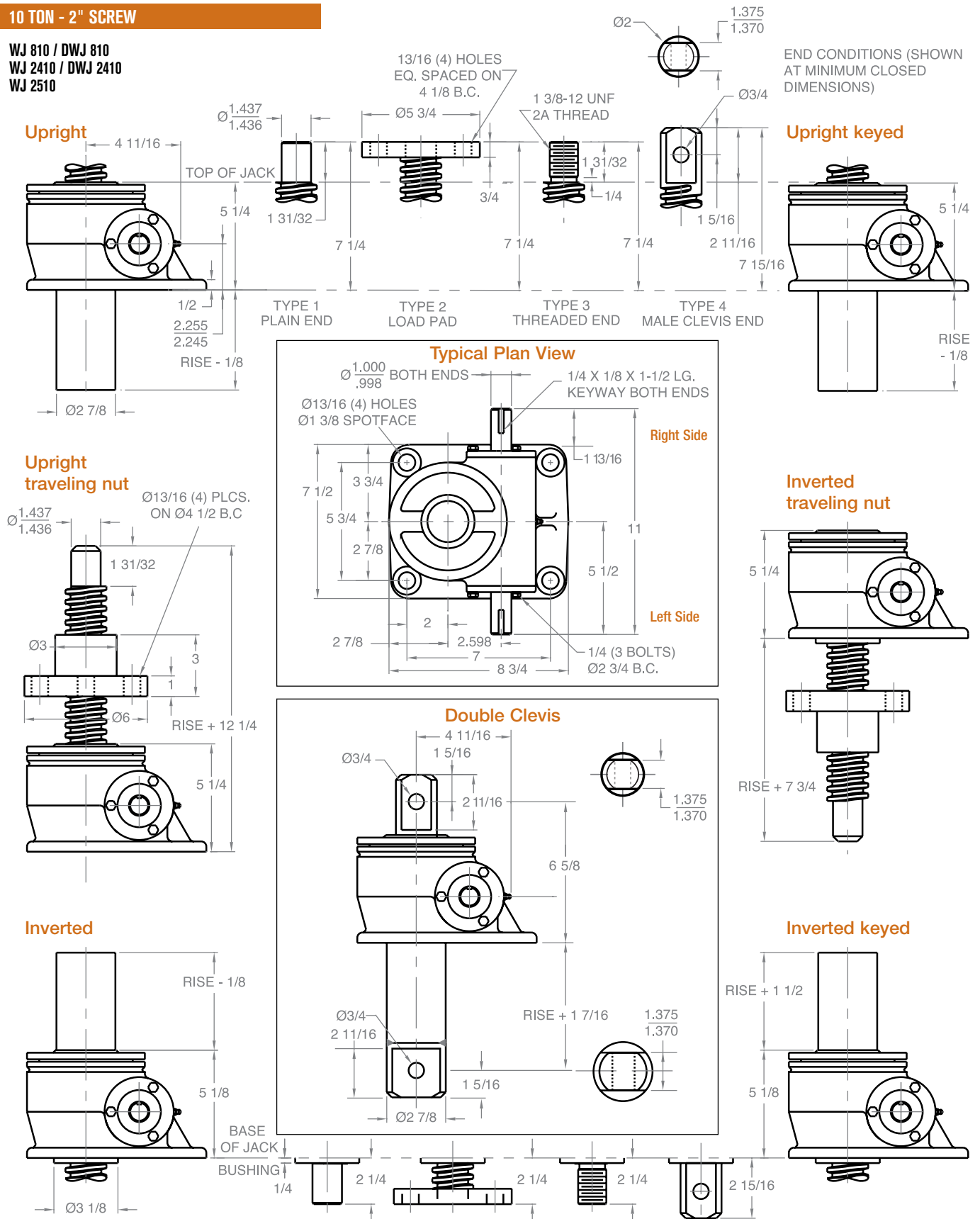

Note: Drawings are artist's conception — not for certification; dimensions are subject to change without notice.

# MACHINE SCREW JACKS

15 TON - 2 1/4" SCREW

WJ 815 / DWJ 815  
WJ 2415 / DWJ 2415  
WJ 2515

## Upright

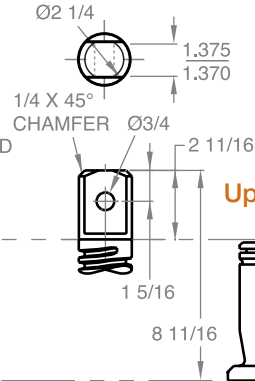
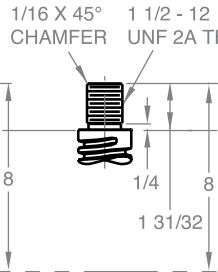
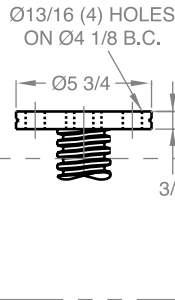
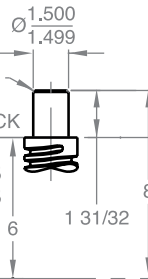
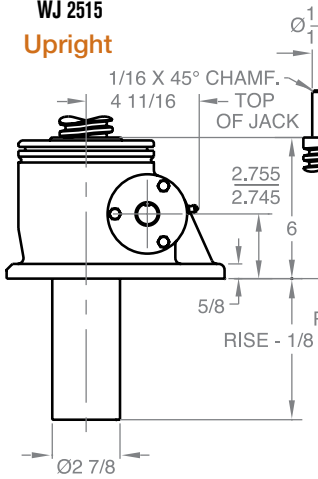

## Upright keyed

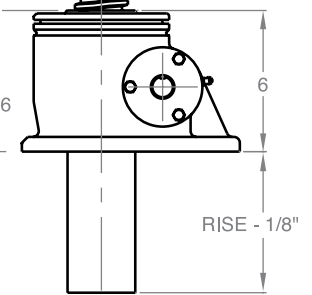

## Typical Plan View

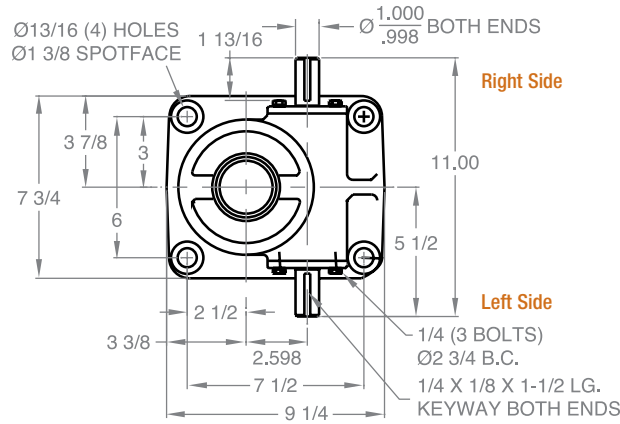

## Upright traveling nut

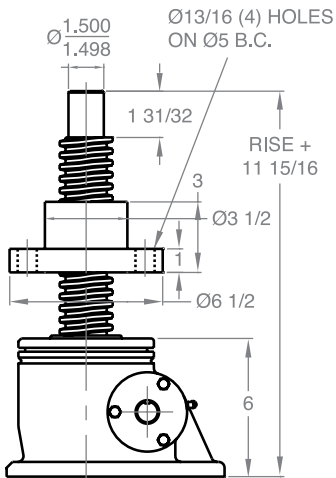

## Inverted traveling nut

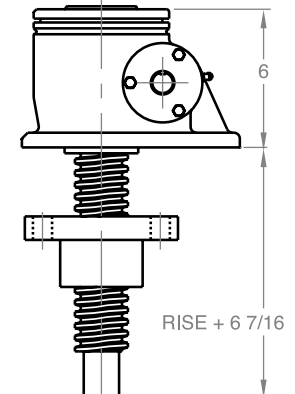

## Inverted

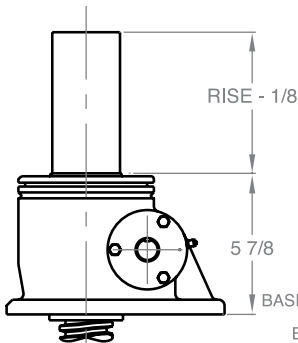

## Double Clevis

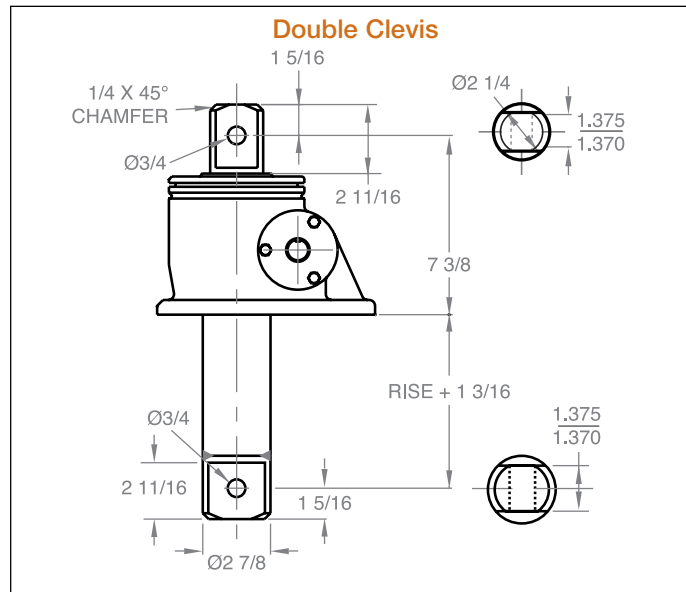

## Inverted keyed

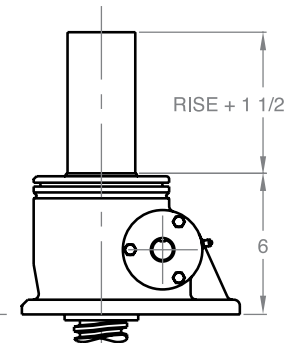

Note: Drawings are artist's conception — not for certification; dimensions are subject to change without notice.

# MACHINE SCREW JACKS

## 20 TON - 2 1/2" SCREW

WJ 820 / DWJ 820  
WJ 2420 / DWJ 2420  
WJ 2520

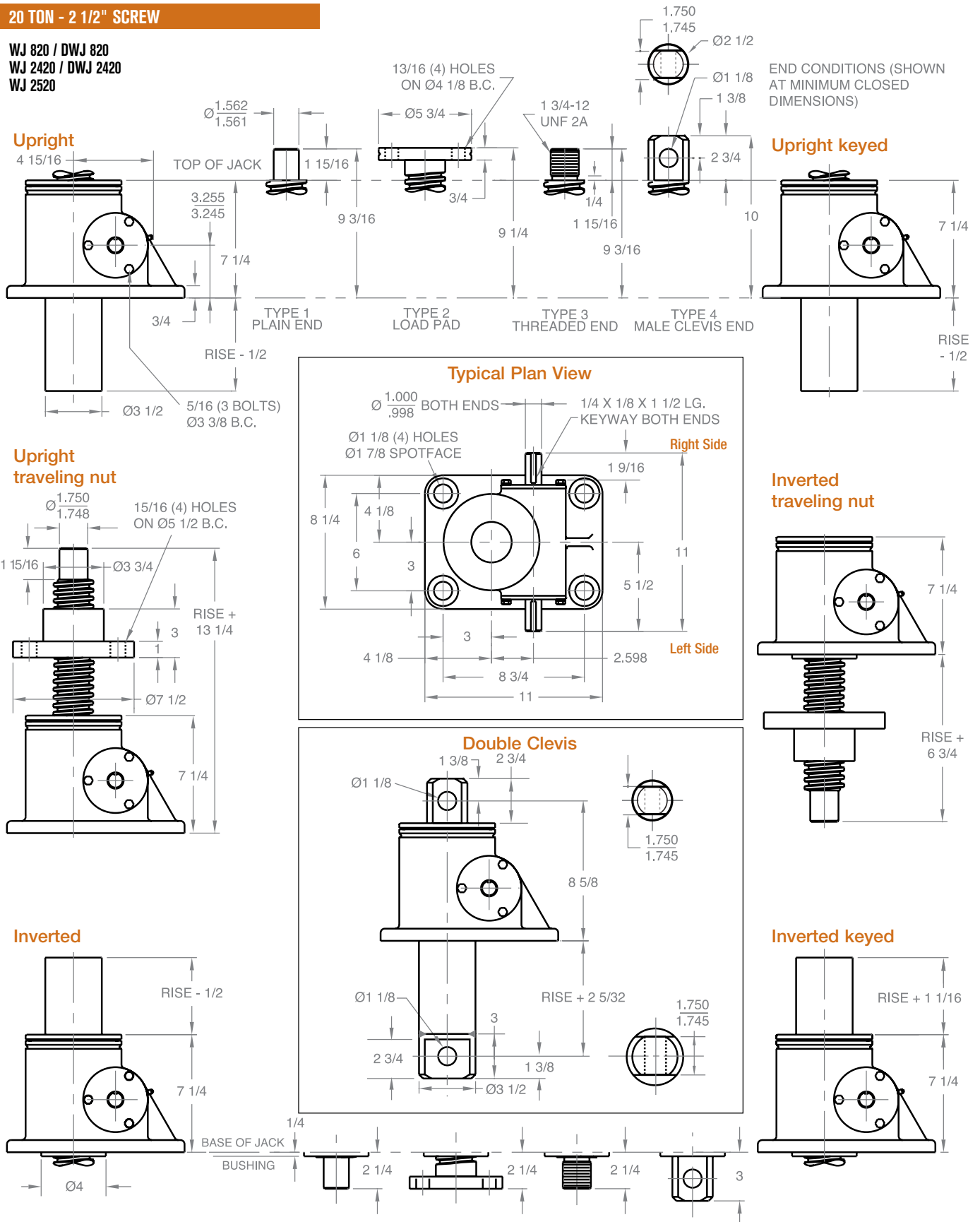

Note: Drawings are artist's conception — not for certification; dimensions are subject to change without notice.

# MACHINE SCREW JACKS

## 25 TON - 3 3/8" SCREW

WJ 1125 / DWJ 1125  
WJ 3225 / DWJ 3225

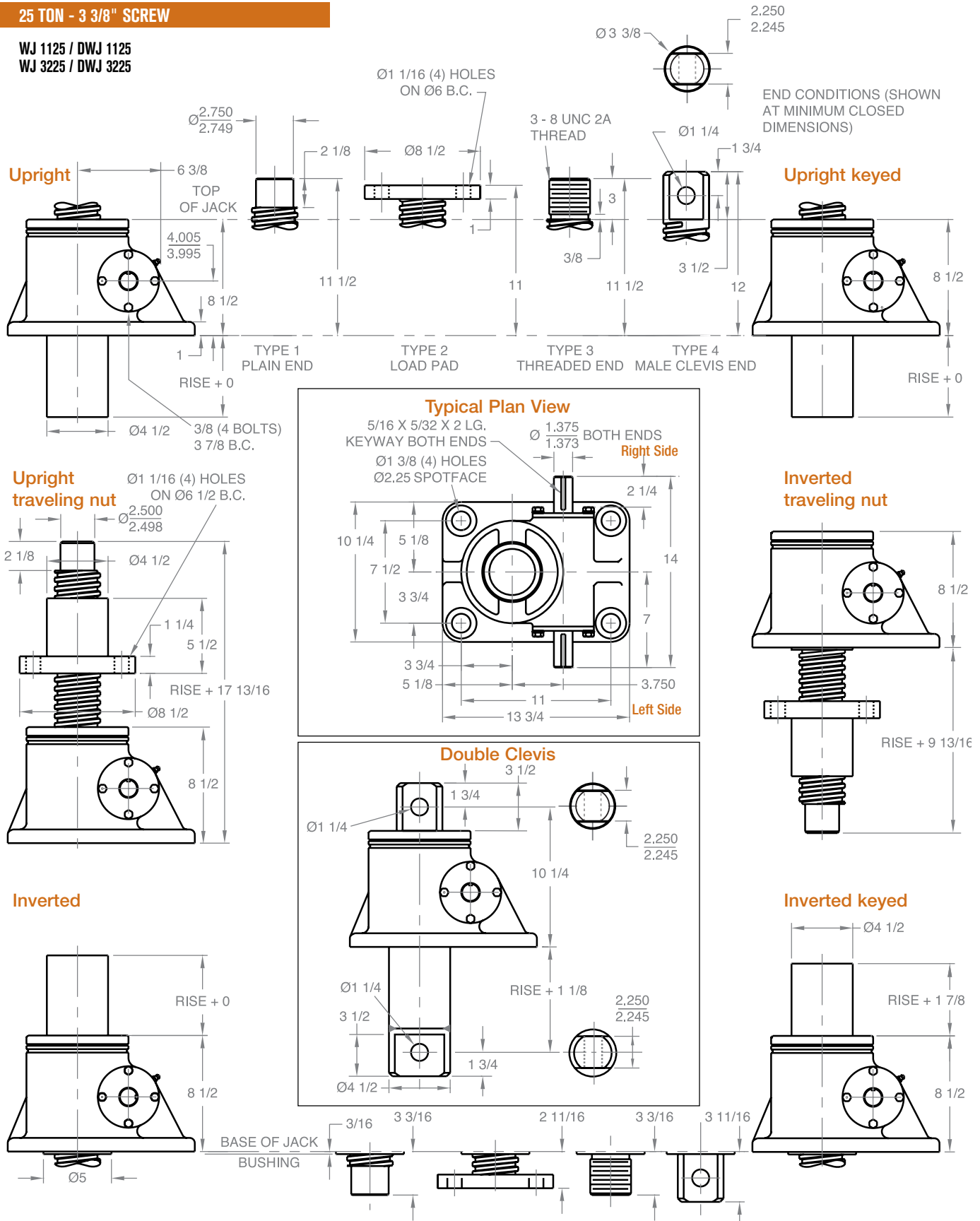

Note: Drawings are artist's conception — not for certification; dimensions are subject to change without notice.

# MACHINE SCREW JACKS

## 30 TON - 3 1/2" SCREW

WJ 1130 / DWJ 1130  
WJ 3230 / DWJ 3230

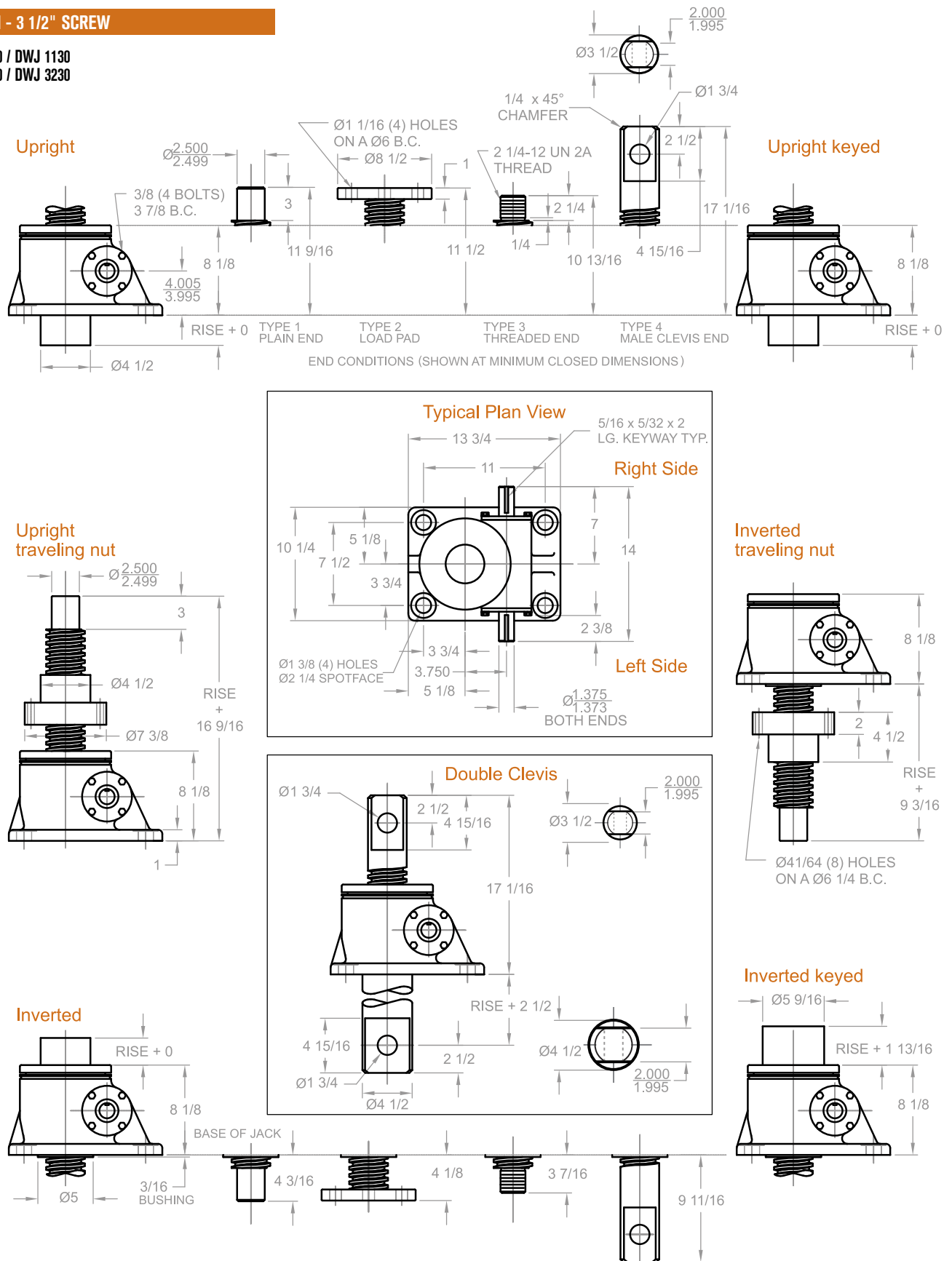

Note: Drawings are artist's conception — not for certification; dimensions are subject to change without notice.

# MACHINE SCREW JACKS

35 TON - 3 3/4" SCREW

WJ 1135  
WJ 3235

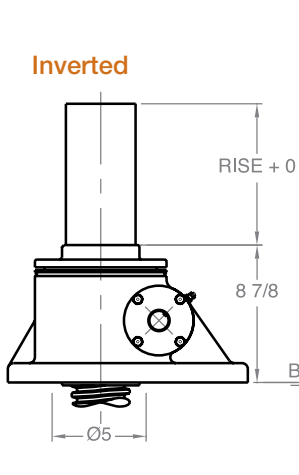
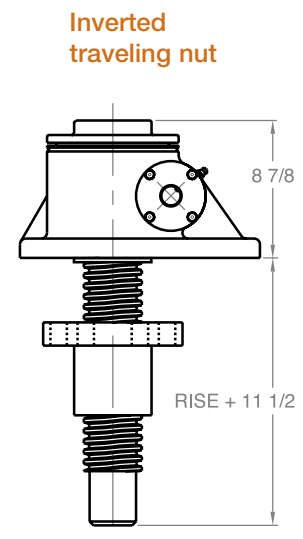
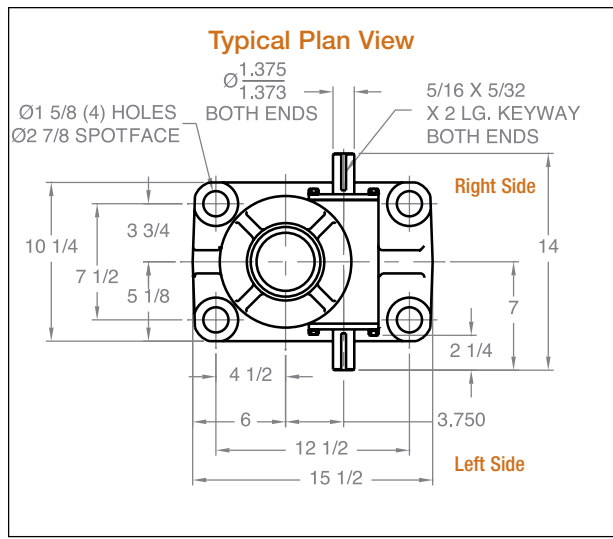
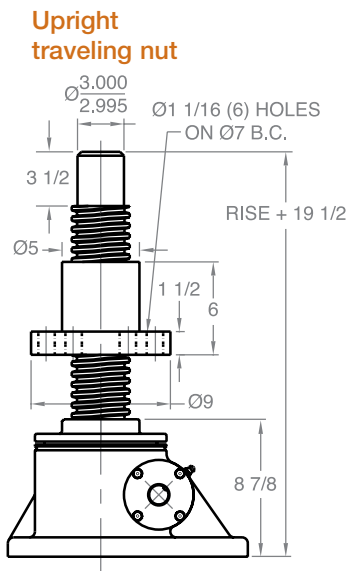
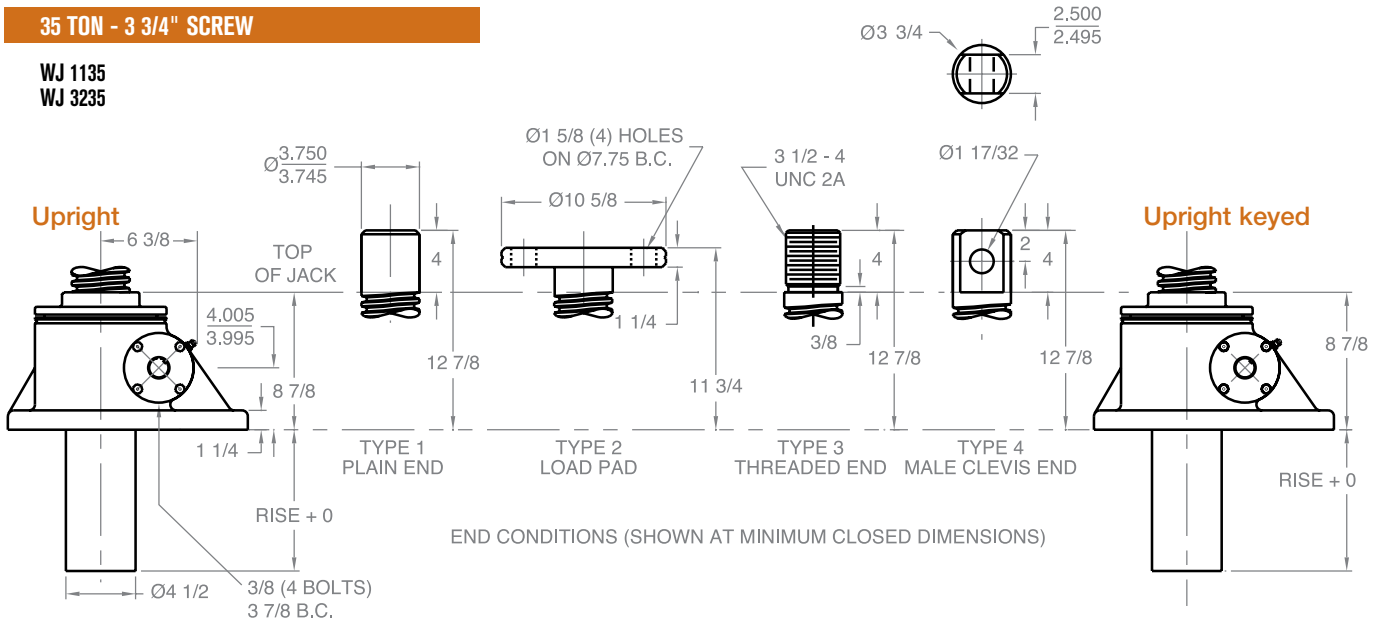

FOR DOUBLE CLEVIS DESIGN CONTACT JOYCE

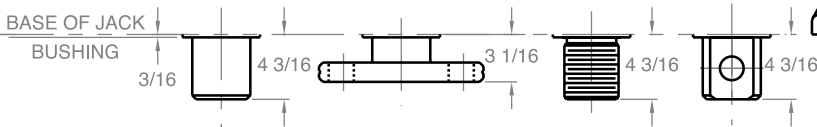
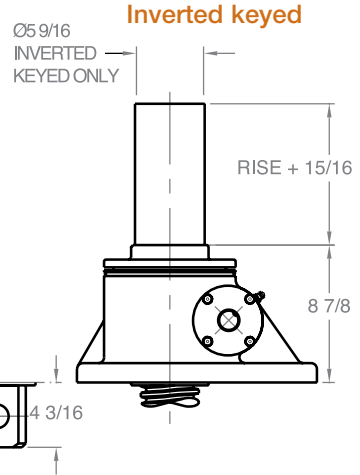

Note: Drawings are artist's conception — not for certification; dimensions are subject to change without notice.

# MACHINE SCREW JACKS

## 50 TON - 4 1/2" SCREW

WJT 1150  
WJT 3250

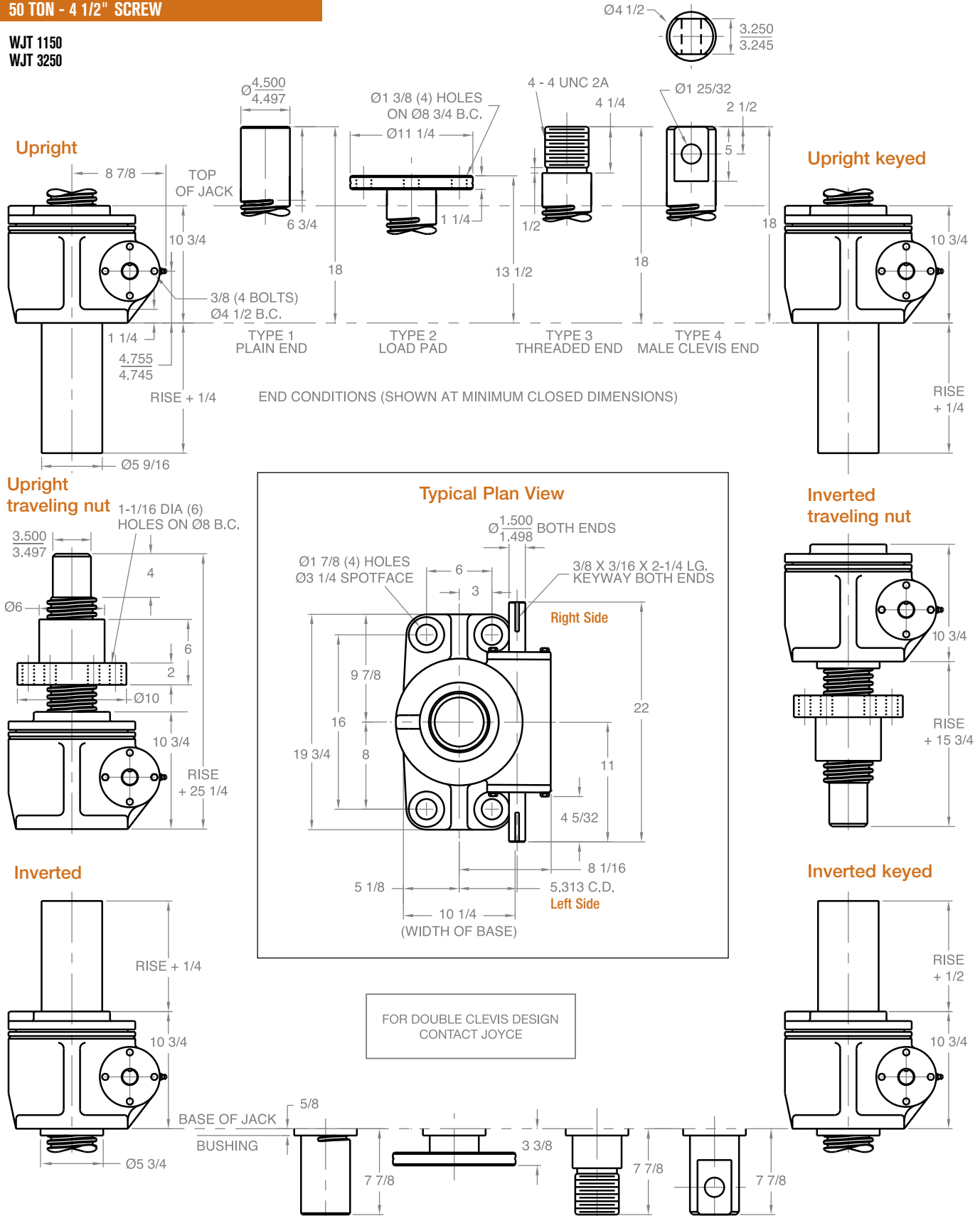

Note: Drawings are artist's conception — not for certification; dimensions are subject to change without notice.

# MACHINE SCREW JACKS

## 50 TON REVERSE BASE - 4 1/2" SCREW

RWJT 1150  
RWJT 3250

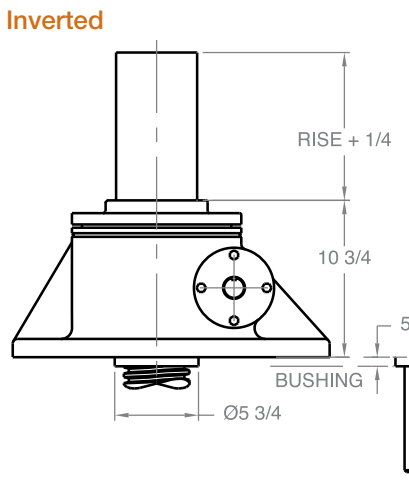
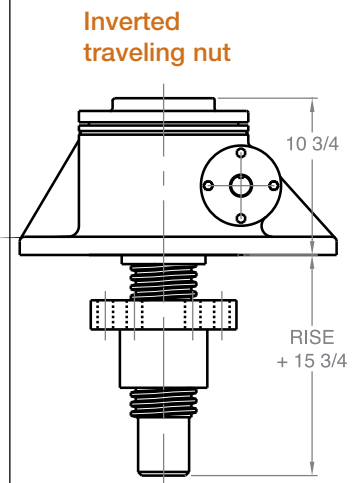
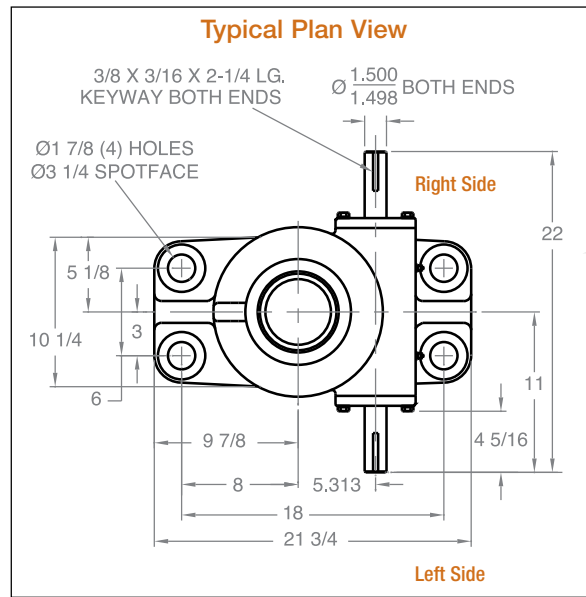
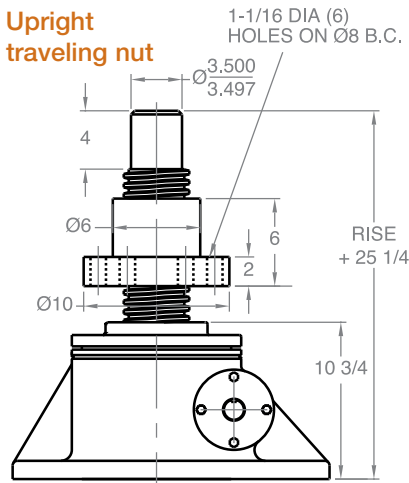
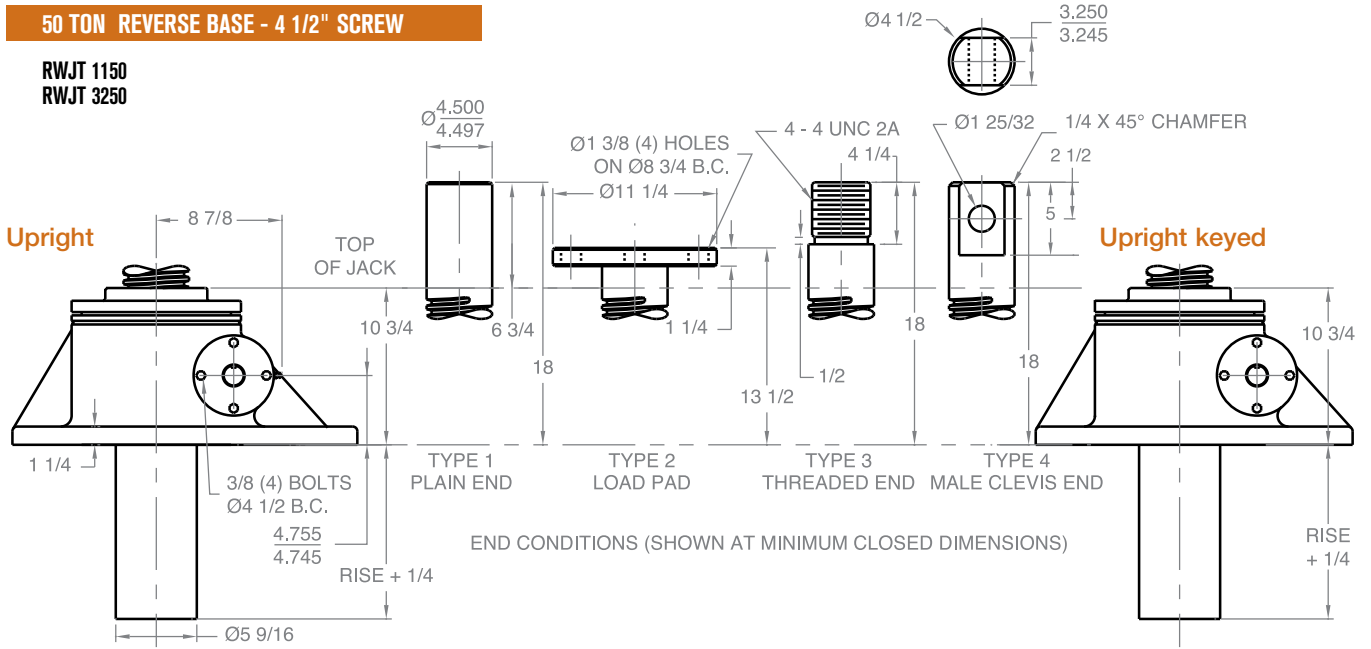

FOR DOUBLE CLEVIS DESIGN CONTACT JOYCE

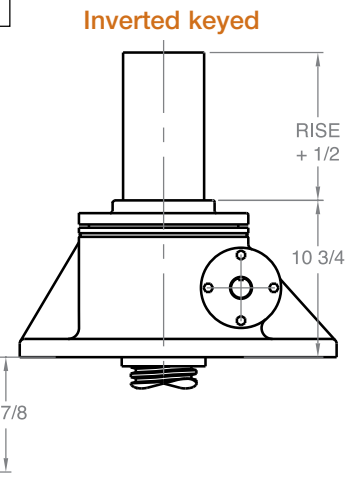

Note: Drawings are artist's conception — not for certification; dimensions are subject to change without notice.



# MACHINE SCREW JACKS

## 75 TON - 5" SCREW

WJ 1175  
WJ 3275

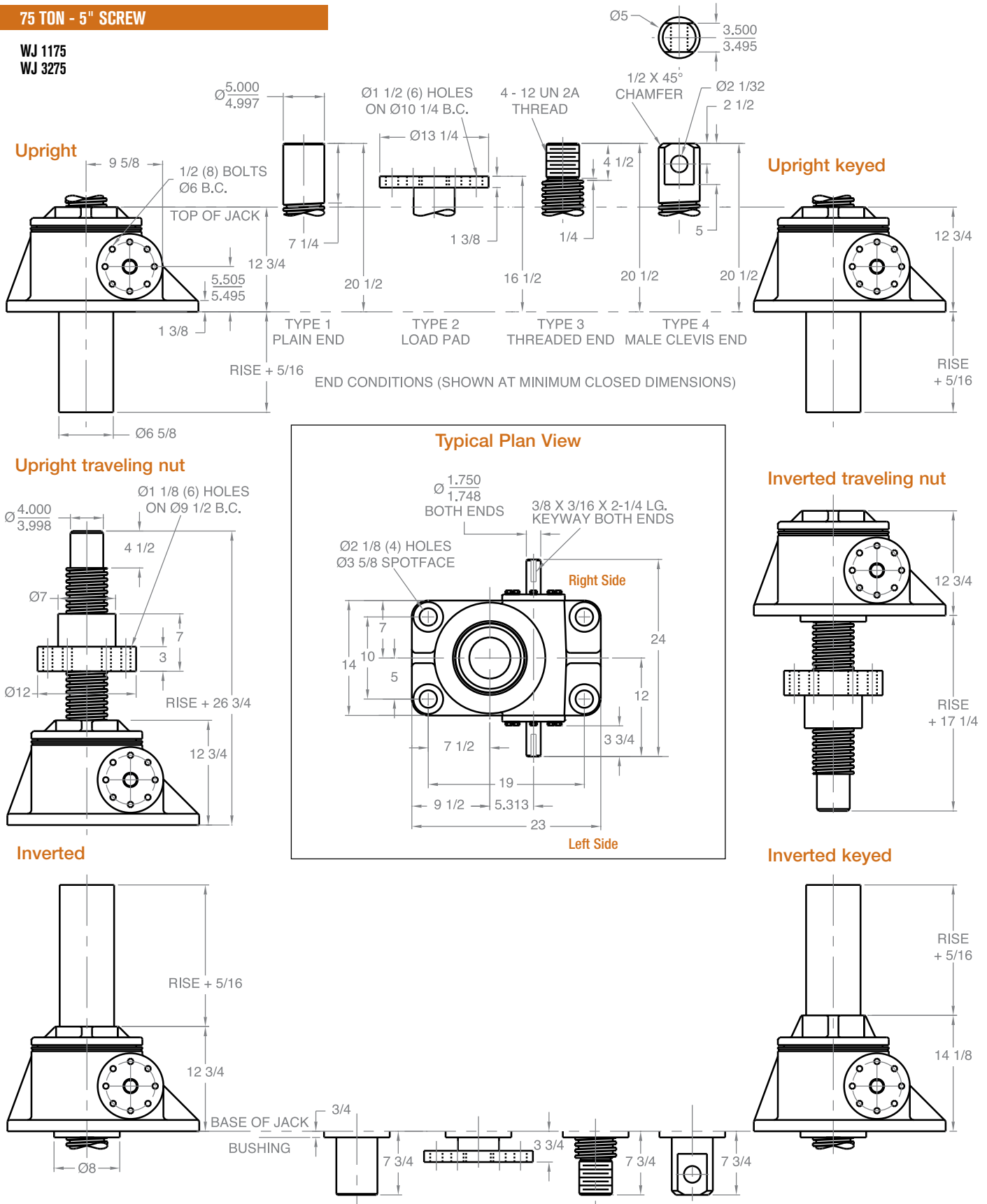

Note: Drawings are artist's conception — not for certification; dimensions are subject to change without notice.

# MACHINE SCREW JACKS

## 100 TON - 6" SCREW

WJ 12100  
WJ 36100

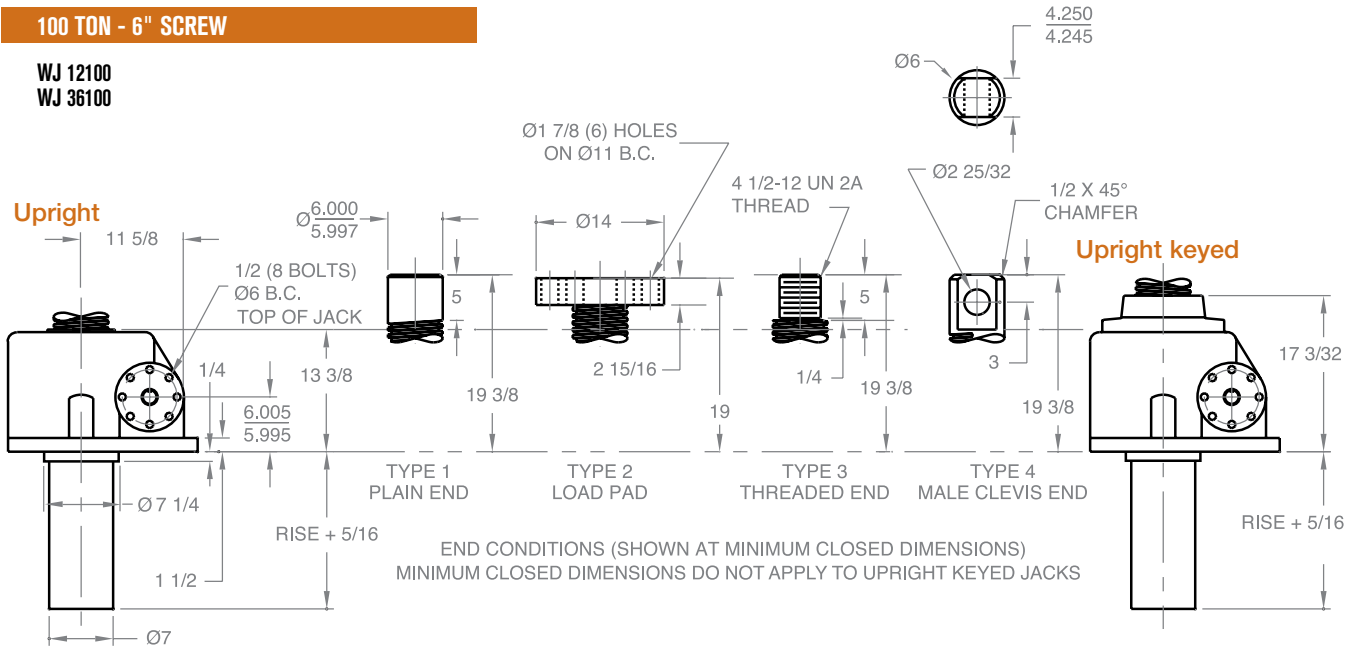

### Upright traveling nut

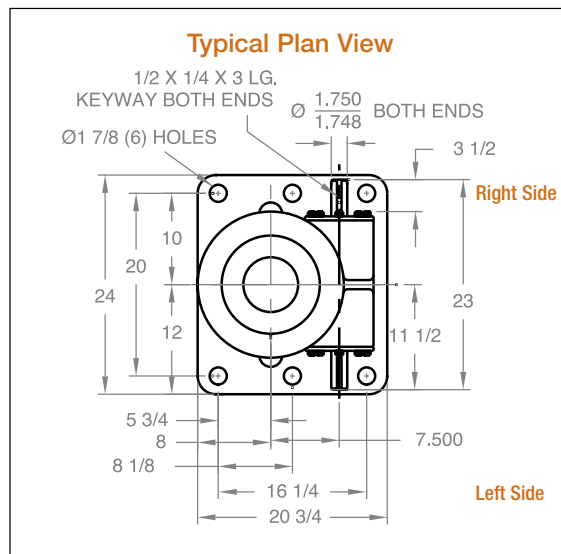
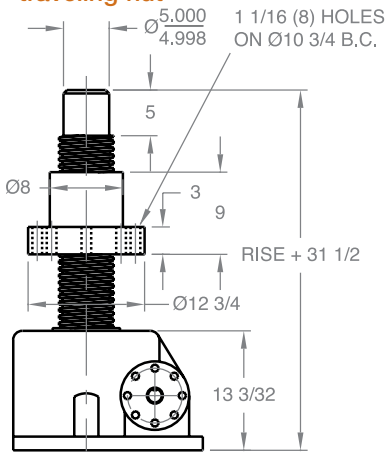

### Inverted traveling nut

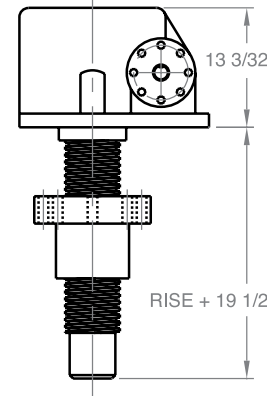

### Inverted

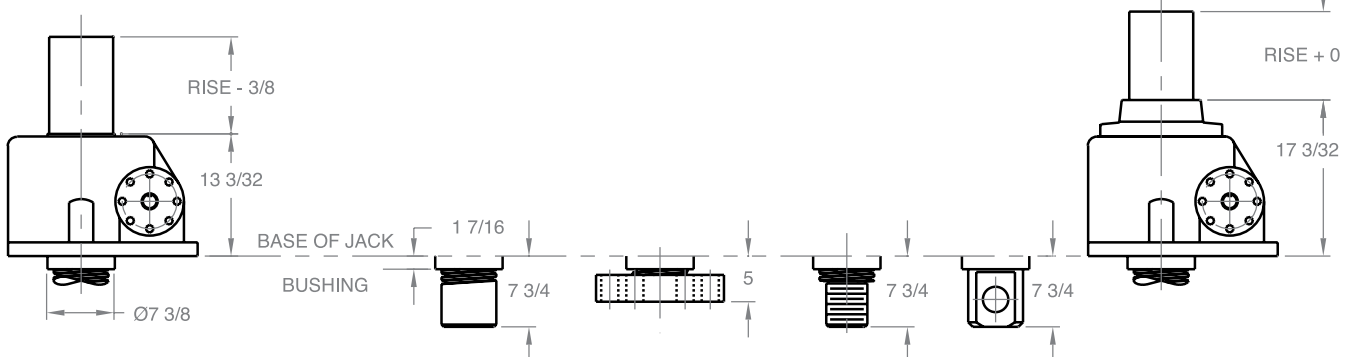

Note: Drawings are artist's conception — not for certification; dimensions are subject to change without notice. Minimum closed dimensions do not apply to upright keyed jacks.

# MACHINE SCREW JACKS

## 150 TON - 7" SCREW

WJ 12150  
WJ 36150

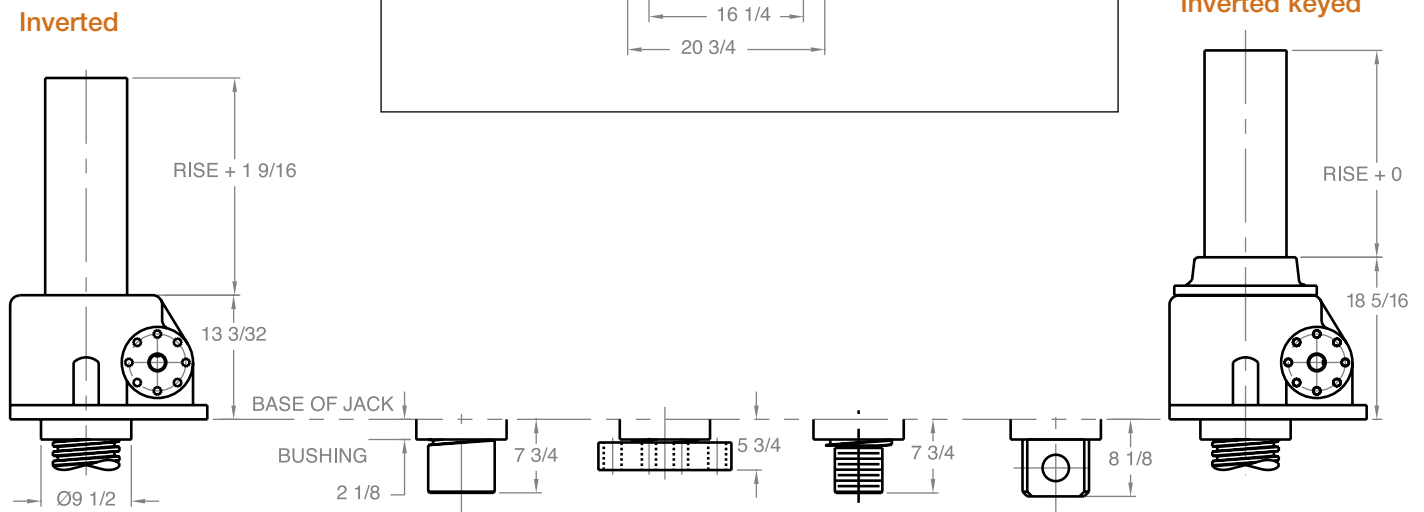
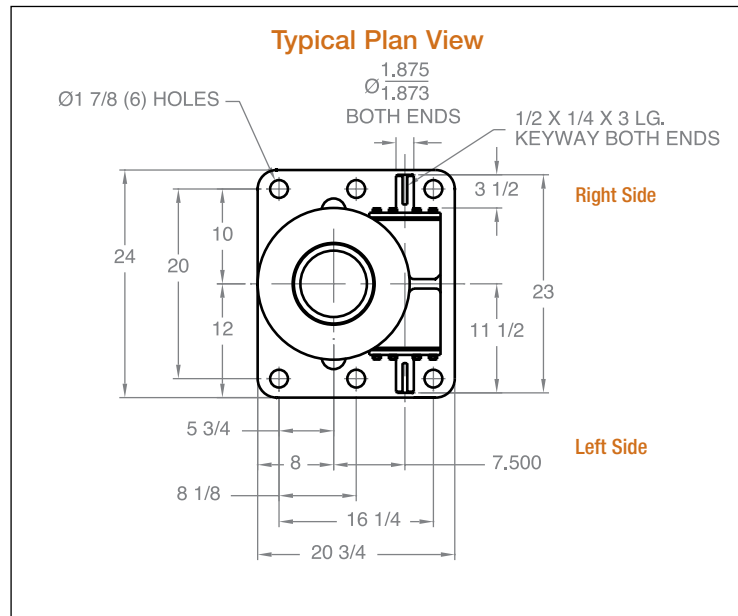
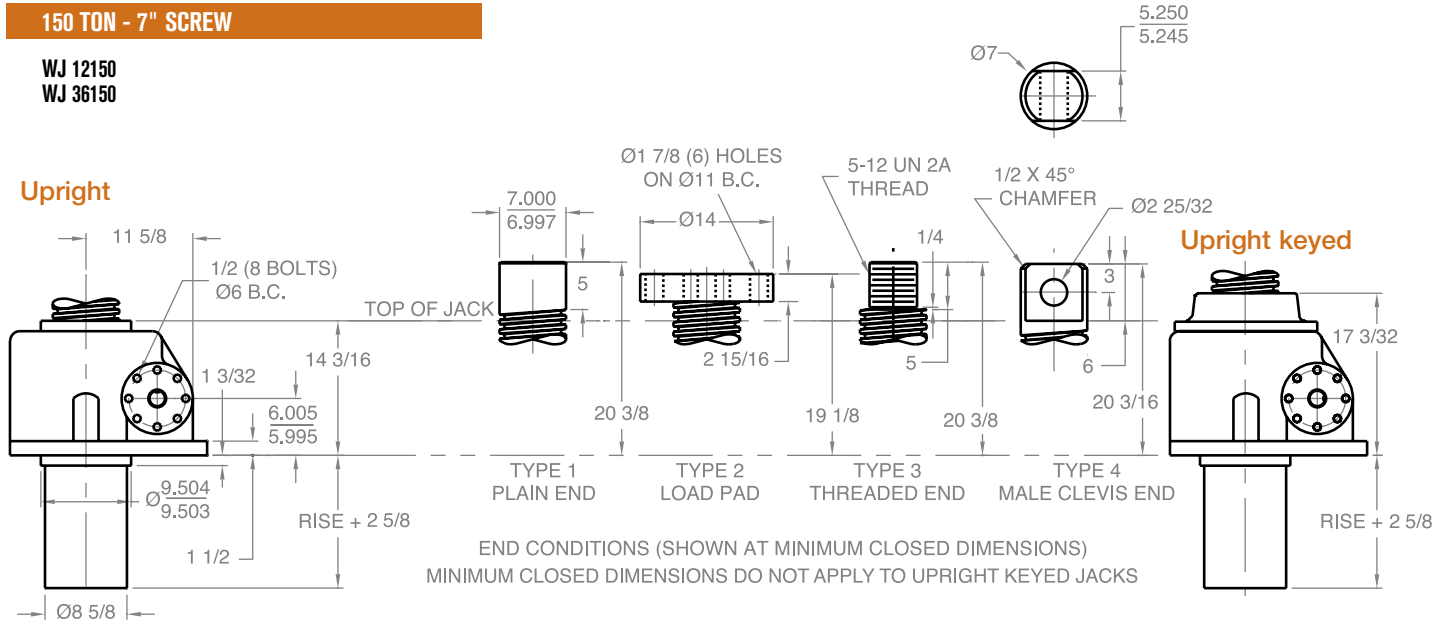

Note: Drawings are artist's conception — not for certification; dimensions are subject to change without notice. Minimum closed dimensions do not apply to upright keyed jacks.

# MACHINE SCREW JACKS

250 TON - 9" SCREW

WJ 50250

Upright

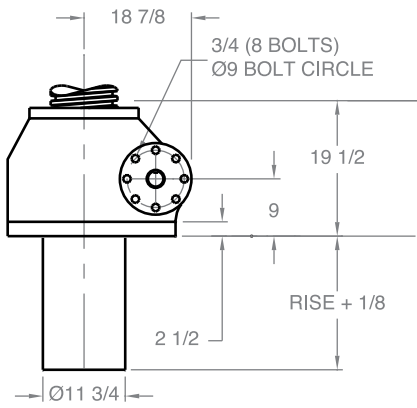

Ø2 3/4 (6) HOLES ON Ø17 B.C.

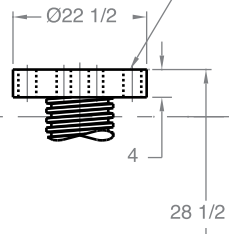

Upright keyed

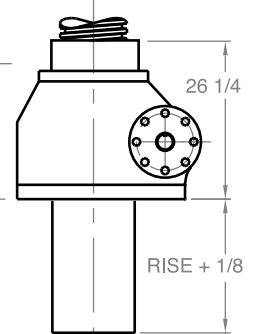

TOP OF JACK

TYPE 2 LOAD PAD

END CONDITION (SHOWN AT MINIMUM CLOSED DIMENSION)

Typical Plan View

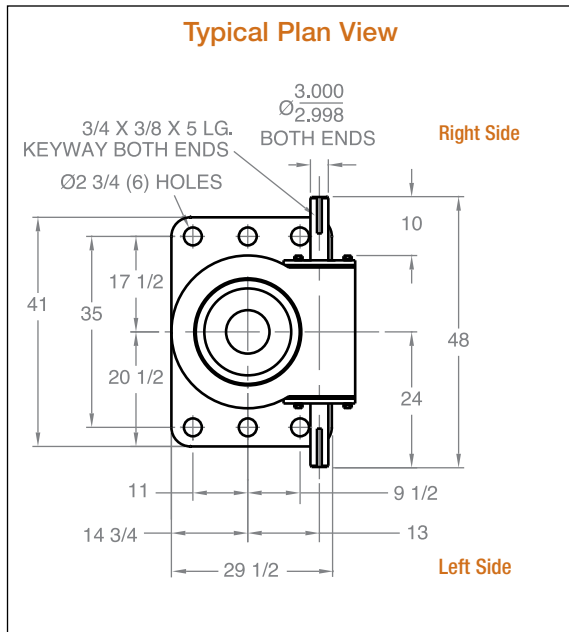

Inverted

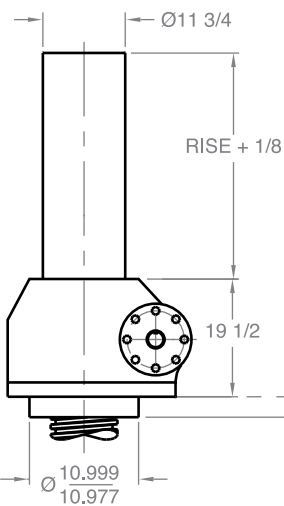

Inverted keyed

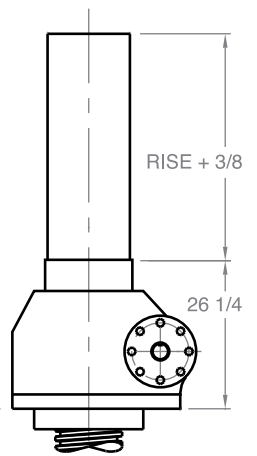

Note: Drawings are artist's conception — not for certification; dimensions are subject to change without notice. Minimum closed dimensions do not apply to upright keyed jacks.

# MACHINE SCREW ComDRIVES®



Joyce machine screw ComDRIVES® combine a machine screw jack, motor and gear reducer into a single compact unit. ComDRIVES are available in 2-ton through 30-ton capacities. They provide travel speeds up to 35.1 inches per minute. ComDRIVES with single lead screws (CD) are self-locking; those with double lead screws (DCD) may require a brake motor or external locking device to hold position.

Four standard end conditions are available and ComDRIVES can be fitted with protective boots. Limit switches, anti-backlash devices, and other options are also available.

#### ComDRIVE Benefits:

- Can power an entire jacking system.
- Reduces the number of components that must be specified.
- Simplifies design.
- Reduces installation costs with only a single plate needed to mount the jack body.
- Reduces the number of couplings and shafts required in multi-jack systems.
- Standard 230/460 volt, 3-phase, 60 hertz motor included.

ComDRIVES can be specified without the motor. The reducer flange accepts standard NEMA motor frame sizes.

Joyce can customize ComDRIVES to meet your specifications. Ask about larger size ComDRIVES.

#### Joyce offers Machine Screw ComDRIVES in several designs including:

- Translating
- Keyed for non-rotation
- Keyed for traveling nut (KFTN)
- Double clevis
- Trunnion mount

A guide for ordering is on pages 46 and 47.

# MACHINE SCREW ComDRIVES® ORDERING INFORMATION

Instructions: Select a model number from this chart.

2-Ton	3-Ton	5-Ton	10-Ton	15-Ton	20-Ton	25-Ton	30-Ton
CD62 CD122 CD242	CD63 CD123 CD243	CD65 CD125 CD245	CD810 CD2410	CD815 CD2415	CD820 CD2420	CD1125 CD3225	CD1130 CD3230
DCD62* DCD122* DCD242*	DCD63* DCD123* DCD243*	DCD65* DCD125* DCD245*	DCD810* DCD2410*	DCD815* DCD2415*	DCD820* DCD2420*	DCD1125* DCD3225*	DCD1130* DCD3230*

**Important Note:** \*Not self-locking, may lower under load. Brake motors or external locking systems are recommended.

**DCD:** Double lead screw.

(For 25:1 ratio contact Joyce.)

## Sample Part Number: CD65U2S-18.50-P1AB-STDX-B

### Jack Configuration

**U=Upright**    **I=Inverted**

### End Conditions

**1=T1**  
(plain end)

**2=T2**  
(load pad)

**3=T3**  
(threaded end)

**4=T4**  
(male clevis)

### Left Side Shaft Code

(see below)

**XXXX=Remove**  
**STDX=Standard**  
**CUST=Custom**

For optional shaft codes, see page 47.

### Right Side Shaft Code

(see below)

**XXXX=Remove**  
**STDX=Standard**  
**CUST=Custom**

For optional shaft codes, see page 47.

### Additional Options\*

**X=Standard Jack**, no additional options

**S=Additional Specification Required** (comment as necessary)

**Anti-Backlash p. 181**

**A=Split Nut**  
**A90=A90 Design**  
**A95=A95 Design**

**Protective Boots pp. 170-173**  
**B=Protective Boot**  
**D=Dual Protective Boot**

**Finishes p. 182**  
**F1=Do Not Paint**  
**F2=Epoxy Paint**  
**F3=Outdoor Paint Process**

**Motor Options**  
**M1=Less Motor**  
**M2=Brake Motor**  
**M3=Single Phase Motor (120VAC)**  
**M4=50Hz Motor**  
**M5=Special Motor**

**Grease/Seals**  
**H1=High Temperature Operation**  
**H2=Food Grade**

**Screw Stops**  
Extending and retracting stops are standard on ComDRIVES.

\* Specify as many options as needed

### ComDRIVE® Rise

Rise is travel expressed in inches and not the actual screw length. When companion jacks are ordered with the ComDRIVE®, their screws are lengthened to match the ComDRIVE®.

### Jack Designs

**S=Translating**    **K=Keyed for Non Rotation**    **N=Traveling Nut**    **D=Double Clevis**    **A=KFTN Trunnion\***  
**T=Trunnion\***

\*Standard trunnion mounts available on 2-ton through 20-ton jacks. (See page 183)

# MACHINE SCREW ComDRIVES<sup>®</sup> SHAFT CODES

**Instructions:** Select the appropriate shaft codes for both right and left hand shafts. One shaft code must be specified for each side of the ComDRIVE<sup>®</sup>.

## Screw Stops (p. 10) and Boots (pp. 170-173)

Extending and retracting screw stops are standard on ComDRIVES. When boots are added to ComDRIVES, the closed height of the unit may be increased.

## Mechanical Counters (p. 180)

CNT0=0.001" Increments

Note: Contact Joyce for availability and options.



## G geared Potentiometers (p. 175)

POTA=0-10V

POTB=4-20mA

POTC=0-10V w/2 switches

POTD=4-20mA w/2 switches

IP65 rated enclosures



## Encoders (pp. 176-177)

ENCA=Absolute Encoder 0-10 VDC, programmable

ENCB=Absolute Encoder 4-20mA, programmable

ENCC=Absolute Encoder CAN Open

ENCD=Absolute Encoder SSI

ENCS=Stainless Steel Incremental Encoder 1024 PPR

ENCX=Incremental Encoder 200 PPR

ENCY=Incremental Encoder 1024 PPR



## ComDRIVE Reducers (pp. 49-57)

Ordering Example: **P2AC**

Motor code from chart at right

### Mounting Positions

### Ratio

Code	P1	P2	P3	P4	Ratio
Left Side Shaft Options					5:1 Code A
					7.5:1 Code B
					10:1 Code C
Right Side Shaft Options					15:1 Code D
					Special Ratio Code X

### Motors

Size	Code
1/4 HP	K
1/3 HP	A
1/2 HP	B
3/4 HP	C
1 HP	D
1-1/2 HP	E
2 HP	F
3 HP	L
5 HP	G
7-1/2 HP	H
10 HP	I
15 HP	J

All standard motors are 3-phase, 208-230/460 VAC or 230/460 VAC. Other motor options are available including international voltages, and single phase AC. Specify the appropriate motor size from the chart above. Refer to the "Additional Options" chart on the preceding page as needed. Brake motors are required for ball screw ComDRIVES<sup>®</sup>. Contact Joyce for options that are not listed.

## Mechanical Limit Switches (p. 174)

Ordering Example: **LA13**

Models	
Model	Code
LS7-402	LI
LS8-402	LA
LS8-404	LB

Number of DPDT Switches (see p. 174)

NOTE:  
Will always be 0 for LS7 models

### Available Positions

	1	2*	3	4	5	6*	7	8
Left Side Shaft Options								
Right Side Shaft Options								

- 2, 3, 5, 10, 15, and 20 ton ComDRIVES are available with positions #1, #3, and #5.
- 25 and 30 ton ComDRIVES are available with positions #1, #4, #7 and #8.
- \* These positions are not standard. Contact Joyce with your requirements.

# MACHINE SCREW ComDRIVES<sup>®</sup> COLUMN LOADING

Machine Screw ComDRIVE<sup>®</sup> Column Loading Chart

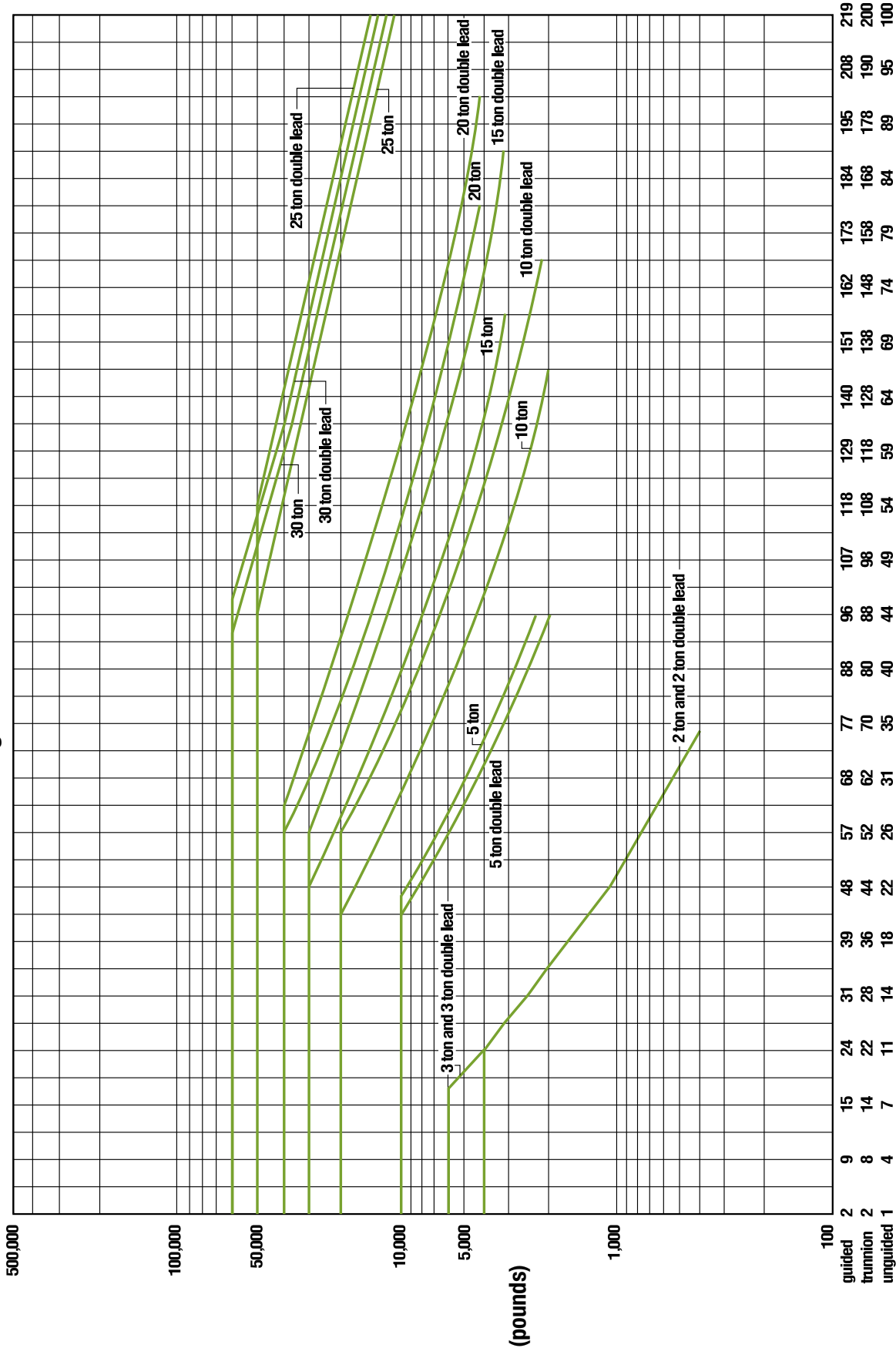

Screw Length (inches)

This chart includes a 2:1 Factor-of-Safety based on the Euler-Johnson equation for column loading (Oberg, Erik et al: Machinery's Handbook, 24th Edition, c. 1992 Industrial Press Inc.) The horizontal portion of each line represents the jack's maximum dynamic capacity. Under static conditions, these lines can be exceeded. Please contact factory for assistance.



# MACHINE SCREW ComDRIVES<sup>®</sup> SPECIFICATIONS

2 Ton Model Number		CD62			CD122		CD242			DCD62			DCD122		DCD242		
Reducer Ratio		5	7 1/2	10	5	7 1/2	5	7 1/2	10	5	7 1/2	10	7 1/2	5	7 1/2	10	
Travel Speed IPM		13.88	9.50	7.04	6.94	4.75	3.47	2.38	1.76	27.75	19.00	14.08	9.50	6.94	4.75	3.52	
Lifting Capacity, Lbs.	1/3 HP	1,865	2,650	3,500	3,350	4,000	4,000	4,000	4,000	1,300	1,850	2,450	3,300	3,830	4,000	4,000	
	1/2 HP	2,875	4,000	4,000	4,000					2,000	2,825	3,720	4,000	4,000			
	3/4 HP	4,000								3,060	4,000						

3 Ton Model Number		CD63			CD123		CD243			DCD63			DCD123		DCD243		
Reducer Ratio		5	7 1/2	10	5	7 1/2	5	7 1/2	10	5	7 1/2	10	7 1/2	5	7 1/2	10	
Travel Speed IPM		13.88	9.50	7.04	6.94	4.75	3.47	2.38	1.76	27.75	19.00	14.08	9.50	6.94	4.75	3.52	
Lifting Capacity, Lbs.	1/3 HP	1,910	2,700	3,555	3,425	4,790	5,610	6,000	6,000	1,335	1,890	2,485	3,350	3,925	5,415	6,000	
	1/2 HP	2,920	4,095	5,380	5,235	6,000	6,000			2,045	2,865	3,765	5,085	6,000	6,000		
	3/4 HP	4,430	6,000		6,000					3,100	4,340		6,000				

5 Ton Model Number		CD65		CD125		CD245		DCD65		DCD125		DCD245	
Reducer Ratio		5		10		10		5		10		10	
Travel Speed IPM		20.81		10.56		5.28		2.64		27.75		14.08	
Lifting Capacity, Lbs.	1 HP	3,760		6,980		10,000		10,000		3,320		6,170	
	1 1/2 HP	5,755								5,085			
	2 HP	7,750								6,845			

10 Ton Model Number		CD810		CD2410		DCD810		DCD2410	
Reducer Ratio		5		10		5		10	
Travel Speed IPM		20.81		10.56		6.94		3.52	
Lifting Capacity, Lbs.	1 HP	3,680		7,070		9,000		16,760	
	1 1/2 HP	5,760				14,090		4,925	
	2 HP	7,840				19,165		6,700	
	3 HP	12,150		20,000		20,000		20,000	
	5 HP							10,385	

15 Ton Model Number		CD815		CD2415		DCD815		DCD2415	
Reducer Ratio		5		10		5		10	
Travel Speed IPM		20.81		10.56		6.94		3.52	
Lifting Capacity, Lbs.	1 HP	3,140		6,200		7,535		14,385	
	1 1/2 HP	5,035				12,085		4,350	
	2 HP	6,925				16,620		5,990	
	3 HP	10,850		20,425		26,040		30,000	
	5 HP	18,515				30,000		16,010	

20 Ton Model Number		CD820		CD2420		DCD820		DCD2420	
Reducer Ratio		5		10		5		10	
Travel Speed IPM		20.81		10.56		6.94		3.52	
Lifting Capacity, Lbs.	1 HP	2,715		5,570		6,520		12,920	
	1 1/2 HP	4,475				10,745		3,730	
	2 HP	6,235				14,965		5,195	
	3 HP	9,880		18,785		23,715		40,000	
	5 HP	17,000				40,000		14,175	

25 Ton Model Number		CD1125		CD3225		DCD1125		DCD3225	
Reducer Ratio		5		10		5		10	
Travel Speed IPM		20.79		10.55		6.93		3.52	
Lifting Capacity, Lbs.	3 HP	9,050		17,165		20,390		36,800	
	5 HP	15,700		29,420		35,390		50,000	
	7 1/2 HP	23,930		45,755		50,000		19,530	
	10 HP	32,625		50,000				26,625	
	15 HP	49,410						40,325	

30 Ton Model Number		CD1130		CD3230		DCD1130		DCD3230	
Reducer Ratio		5		10		5		10	
Travel Speed IPM		20.82		10.57		6.94		3.52	
Lifting Capacity, Lbs.	3 HP	9,435		17,540		21,260		37,620	
	5 HP	16,100		29,815		36,280		60,000	
	7 1/2 HP	24,335		46,170		54,840		19,430	
	10 HP	33,040		60,000		60,000		26,385	
	15 HP	49,845						39,800	

**Important Note:** DCD models may lower under load. Brake motors or external locking systems are recommended.

# MACHINE SCREW ComDRIVES®

## 2 TON - 1" SCREW

CD 62 / DCD 62  
 CD 122 / DCD 122  
 CD 242 / DCD 242

### Upright

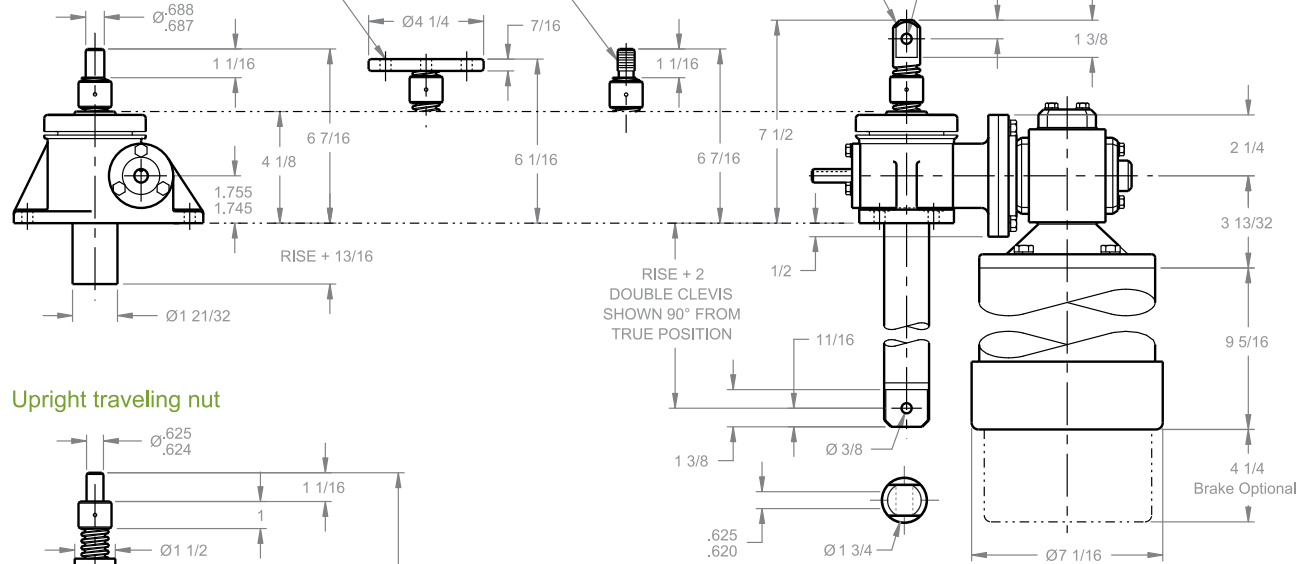

### Upright traveling nut

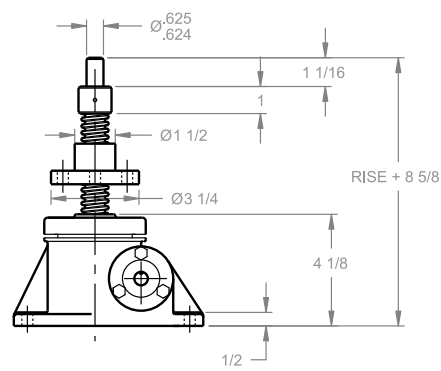

### Inverted traveling nut

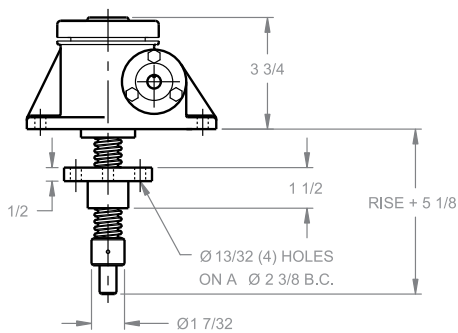

### Inverted

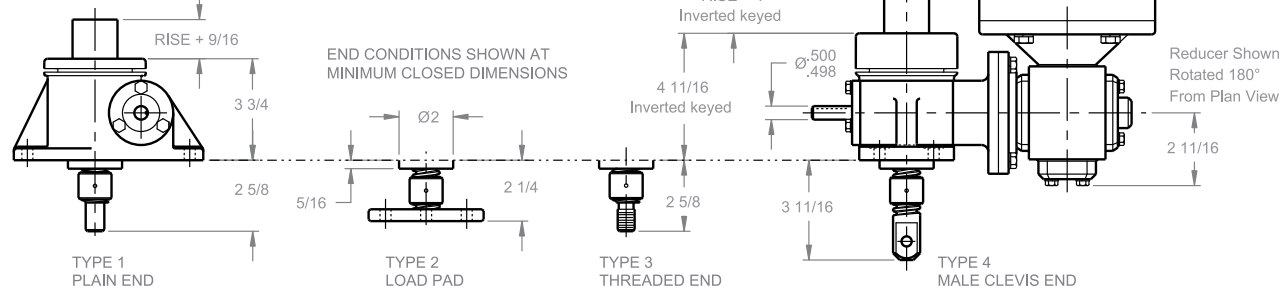

NOTE: FOR LIFTING CAPACITIES SEE PAGE 49

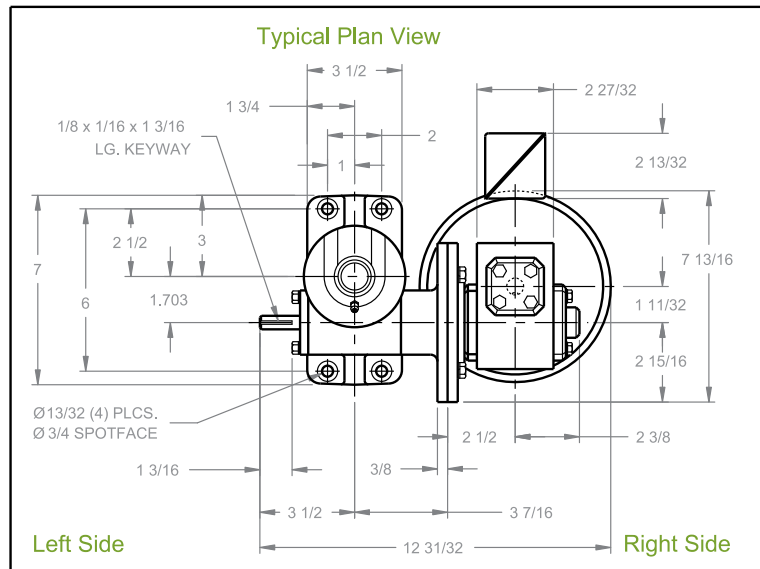

Note: Drawings are artist's conception — not for certification; dimensions are subject to change without notice.

# MACHINE SCREW ComDRIVES®

## 3 TON - 1" SCREW

CD 63 / DCD 63  
 CD 123 / DCD 123  
 CD 243 / DCD 243

### Upright

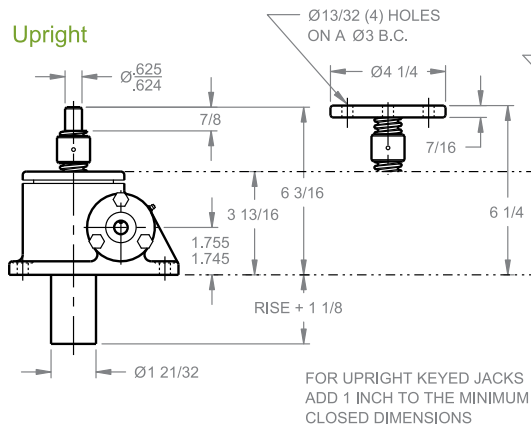

### Upright traveling nut

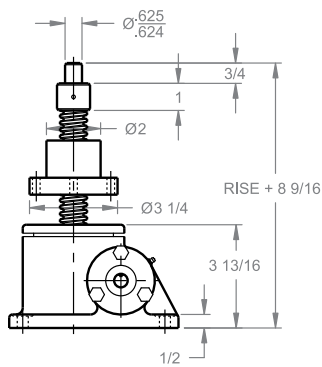

### Inverted traveling nut

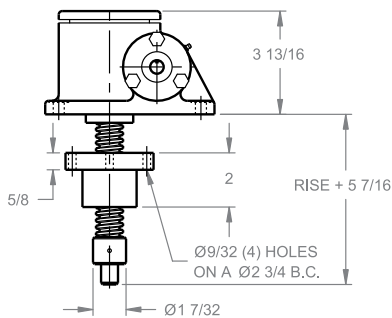

### Inverted

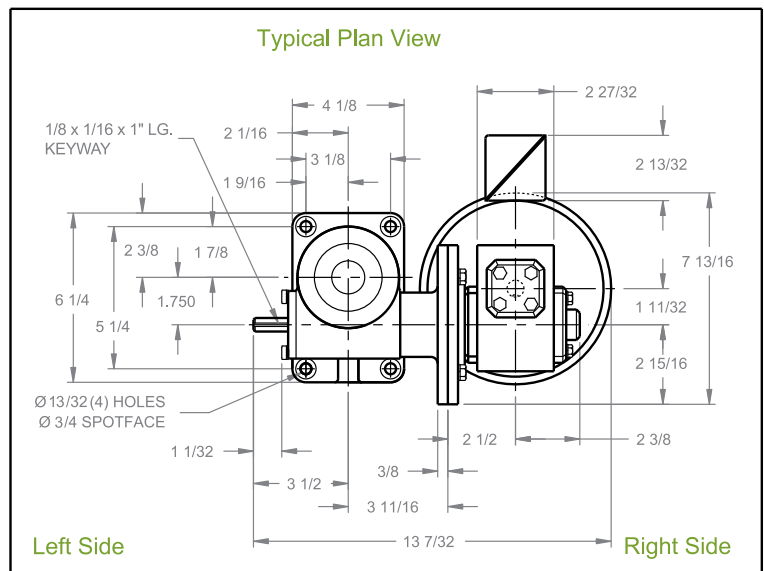
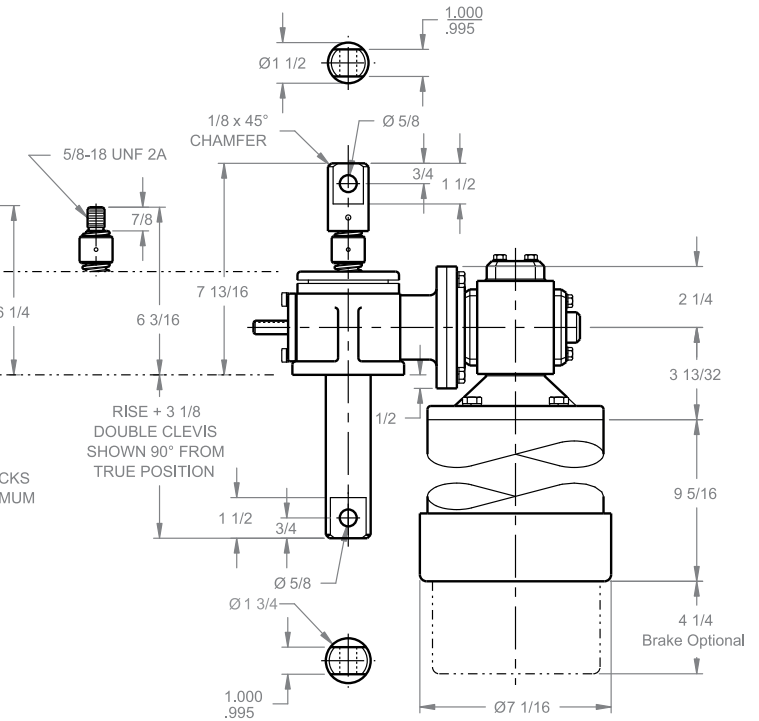
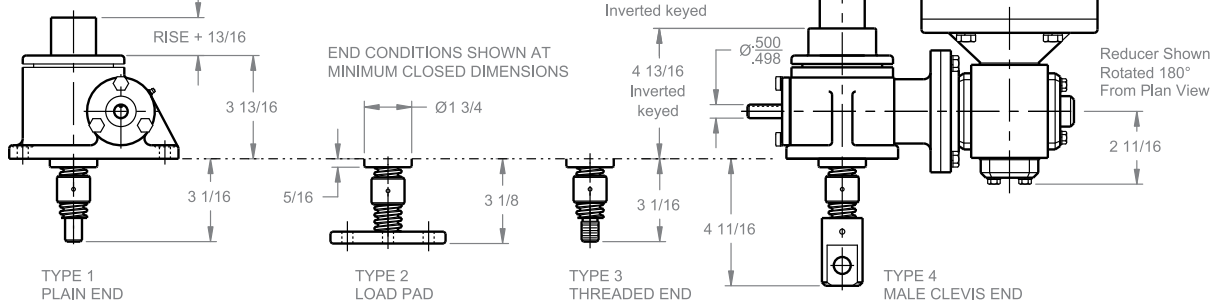

NOTE: FOR LIFTING CAPACITIES SEE PAGE 49

Note: Drawings are artist's conception — not for certification; dimensions are subject to change without notice.

# MACHINE SCREW ComDRIVES<sup>®</sup>

## 5 TON - 1 1/2" SCREW

CD 65 / DCD 65  
 CD 125 / DCD 125  
 CD 245 / DCD 245

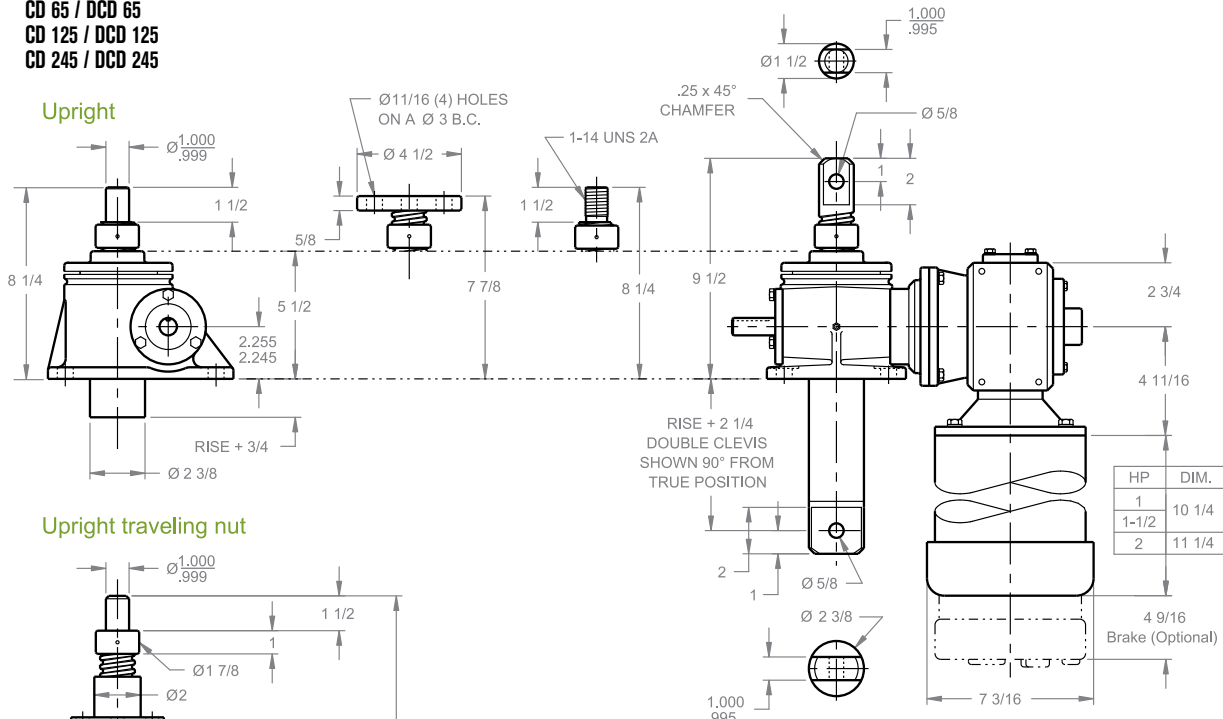

### Upright traveling nut

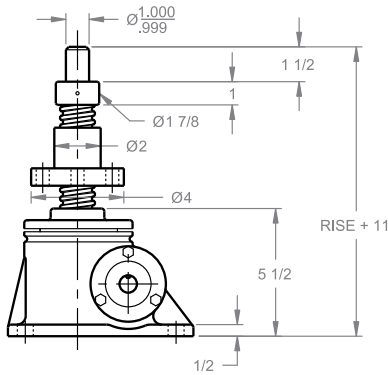

### Inverted traveling nut

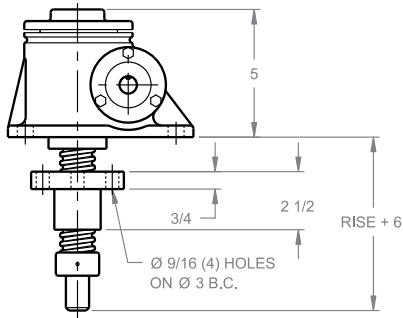

### Inverted

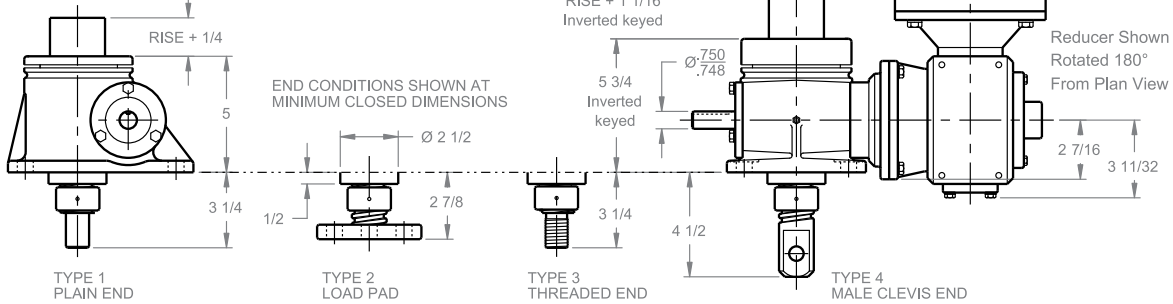

NOTE: FOR LIFTING CAPACITIES SEE PAGE 49

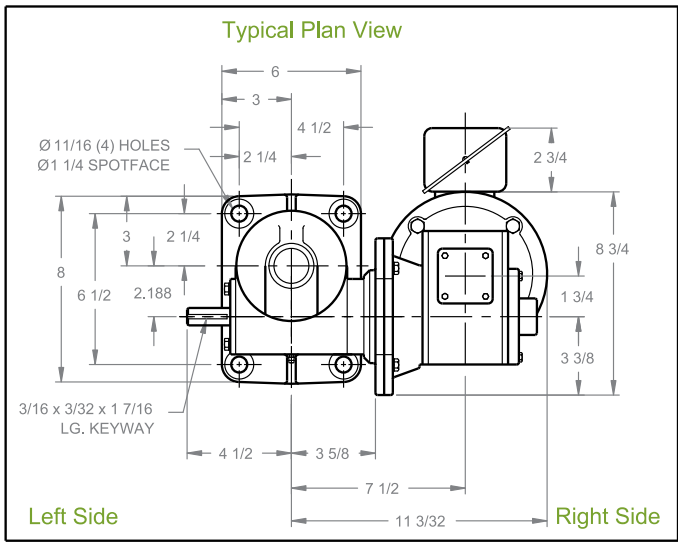

Note: Drawings are artist's conception — not for certification; dimensions are subject to change without notice.

# MACHINE SCREW ComDRIVES®

## 10 TON - 2" SCREW

CD 810 / DCD 810  
CD 2410 / DCD 2410

### Upright

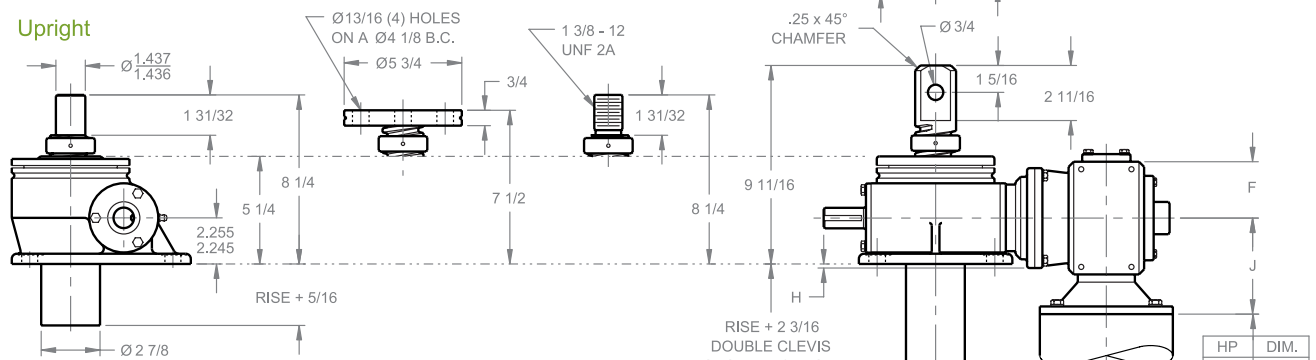

### Upright traveling nut

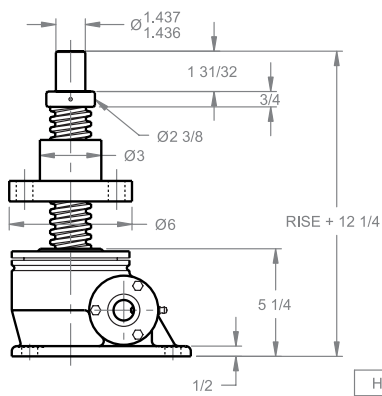

### Inverted traveling nut

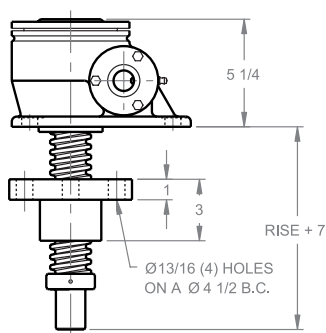

### Inverted

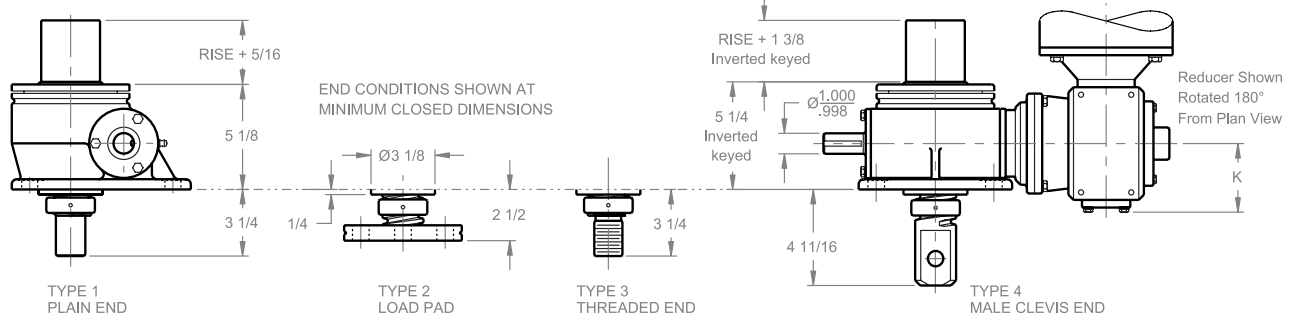

NOTE: FOR LIFTING CAPACITIES SEE PAGE 49

HP	DIM.
1	10 1/4
1-1/2	11 1/4
2	17 3/8
3	18 3/4

Brake (Optional)

HP	DIM.
1	4 9/16
1-1/2	7 9/16
2	
3	
5	

REDUCER DIMENSIONS

HP	1, 1 1/2, 2	3, 5
A	8 11/32	8 29/32
B	11 21/32	13 17/32
C	1 3/4	2 5/8
D	3 3/8	4 7/16
E	8 7/16	11 11/16
F	2 3/4	3 7/8
G	4 15/32	4 15/32
H	3/16	1 5/8
J	4 11/16	5 3/4
K	3 11/32	4 5/16

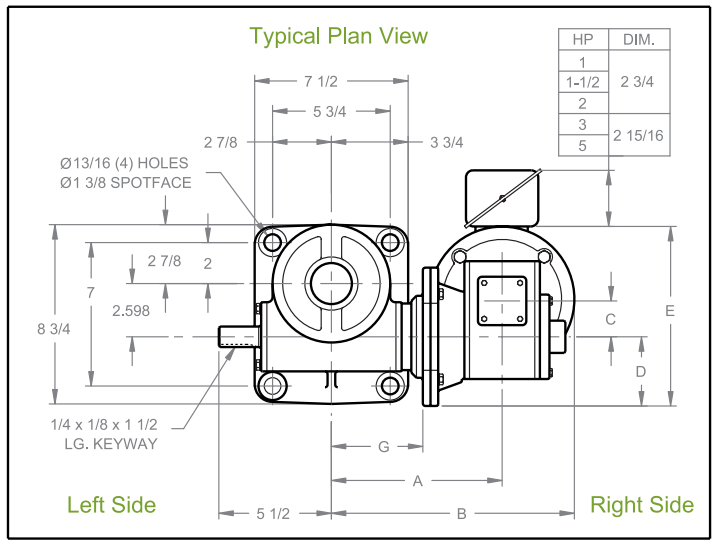

Note: Drawings are artist's conception — not for certification; dimensions are subject to change without notice.

# MACHINE SCREW ComDRIVES®

## 15 TON - 2 1/4" SCREW

CD 815 / DCD 815  
CD 2415 / DCD 2415

### Upright

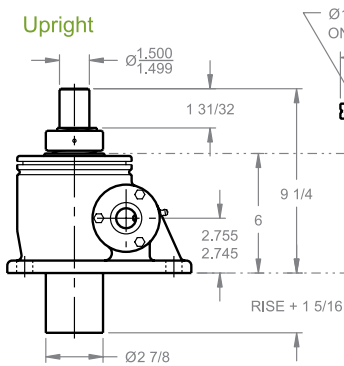

### Upright traveling nut

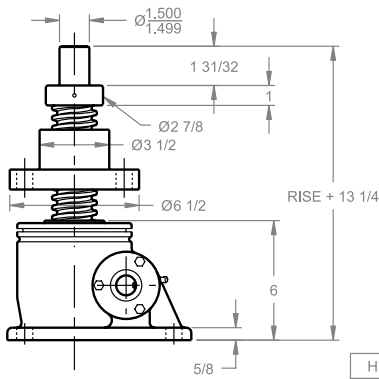

### Inverted traveling nut

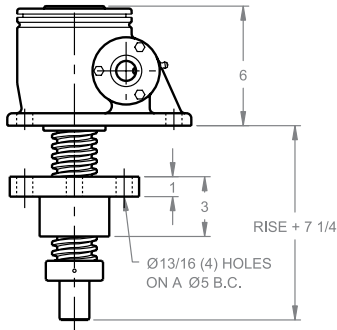

### Inverted

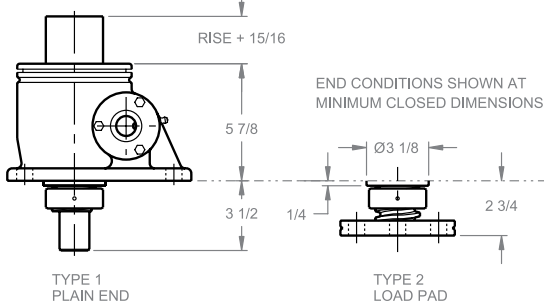

NOTE: FOR LIFTING CAPACITIES SEE PAGE 49

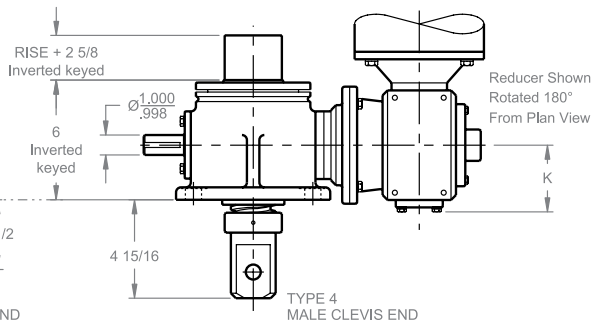
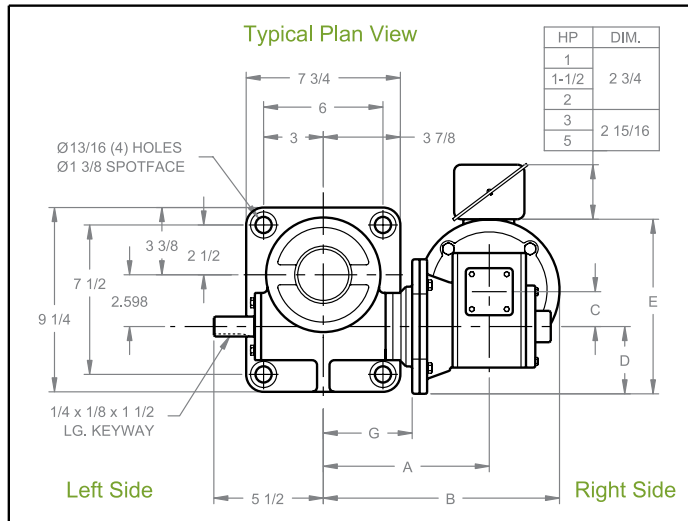
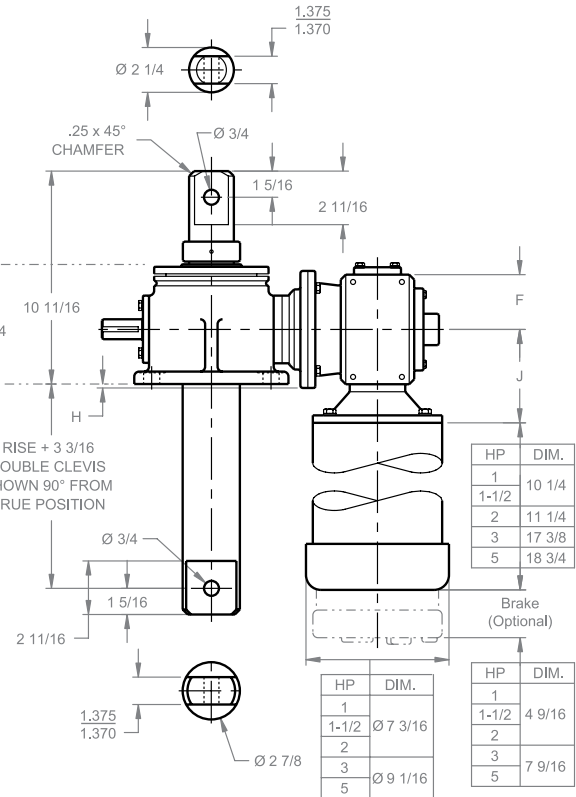

Note: Drawings are artist's conception — not for certification; dimensions are subject to change without notice.

# MACHINE SCREW ComDRIVES®

## 20 TON - 2 1/2" SCREW

CD 820 / DCD 820  
CD 2420 / DCD 2420

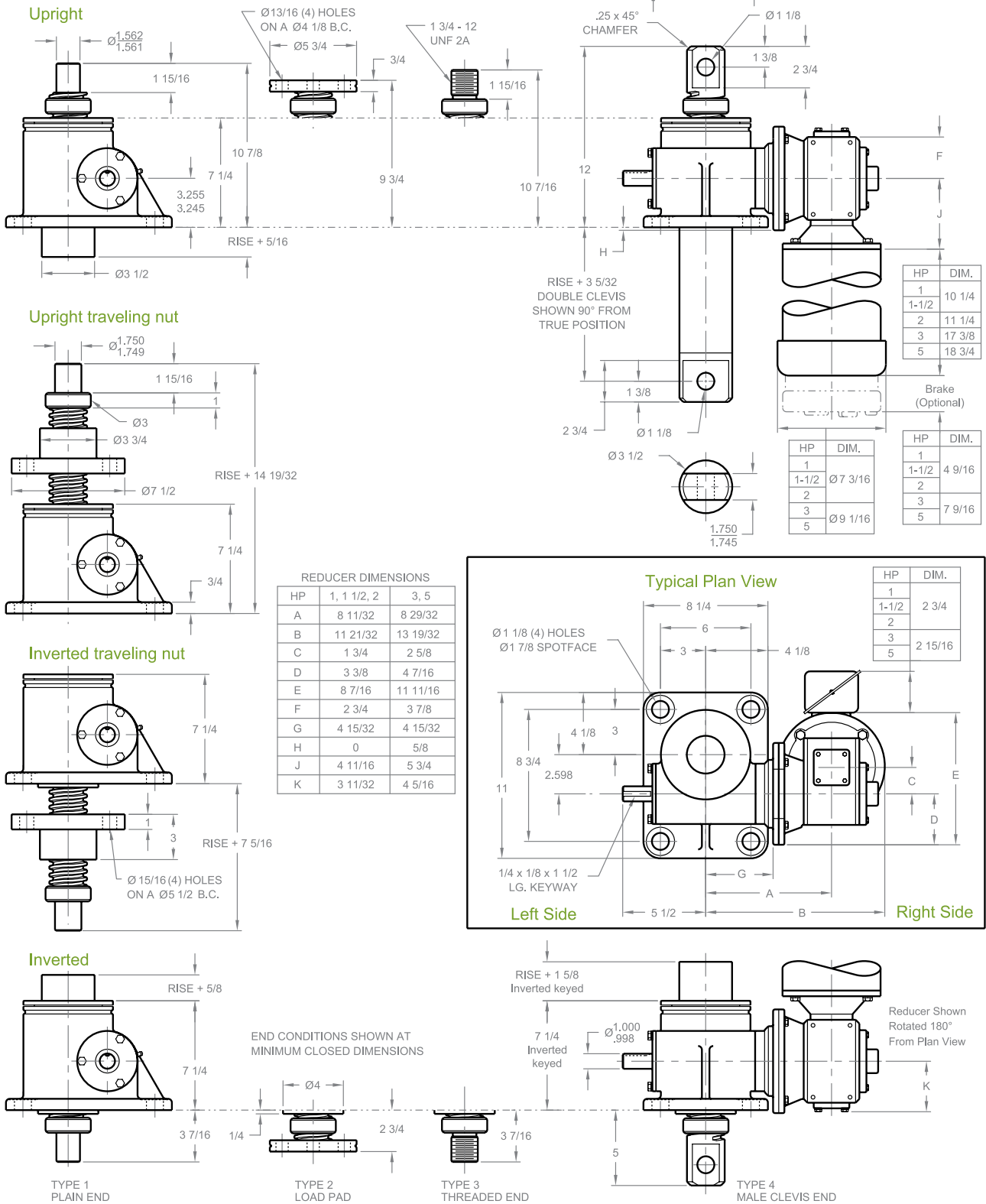

Note: Drawings are artist's conception — not for certification; dimensions are subject to change without notice.

# MACHINE SCREW ComDRIVES®

## 25 TON - 3 3/8" SCREW

CD 1125 / DCD 1125  
CD 3225 / DCD 3225

### Upright

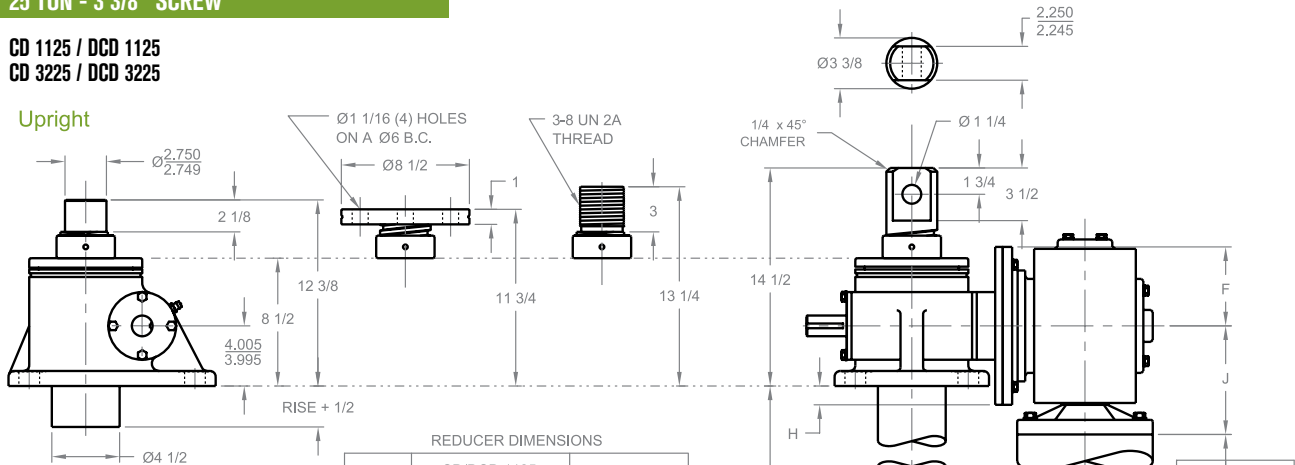

### Upright traveling nut

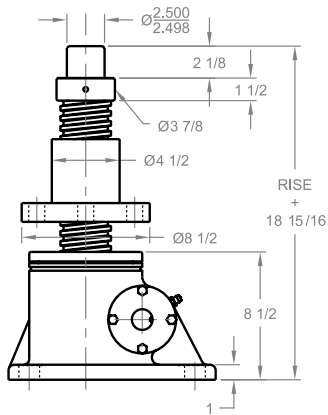

REDUCER DIMENSIONS						
MODEL	CD/DCD 1125 CD/DCD 3225			CD/DCD 1125		
RATIO	5:1	10:1	5:1	10:1	5:1	10:1
HP	3	5	5	7 1/2	7 1/2	15
A	9 17/32	9 31/32	9 31/32	11 19/32	11 19/32	11 19/32
B	13 1/32	13 29/32	13 29/32	16 3/32	16 3/32	16 3/32
C	2 5/8	3 1/4	3 1/4	4 1/4	4 1/4	4 1/4
D	4 7/16	5 1/2	5 1/2	6 1/2	6 1/2	6 1/2
E	11 9/16	12 3/4	12 3/4	15 1/4	15 1/4	15 1/4
F	3 9/16	4 1/2	4 1/2	5 1/4	5 1/4	5 1/4
G	5 1/2	5 1/2	5 1/2	5 1/2	5 1/2	5 1/2
H	0	1/2	1/2	1 1/4	1 1/4	1 1/4
J	4 11/16	6 3/4	6 3/4	7 1/4	7 1/4	7 1/4
K	3 11/32	4 5/16	4 5/16	6 1/8	6 1/8	6 1/8

RISE + 2 5/8  
DOUBLE CLEVIS  
SHOWN 90° FROM  
TRUE POSITION

HP	DIM.
3	17 3/8
5	18 3/4
7 1/2	15 13/16
10	16 5/8
15	16 5/8

BRAKE  
(OPTIONAL)

HP	DIM.
3	Ø9 1/16
5	Ø9 1/16
7 1/2	Ø10 7/8
10	Ø10 7/8
15	Ø12 3/8

HP	DIM.
3	7 9/16
5	8 1/4
7 1/2	8 1/4
10	8 7/8
15	9 1/16

### Inverted traveling nut

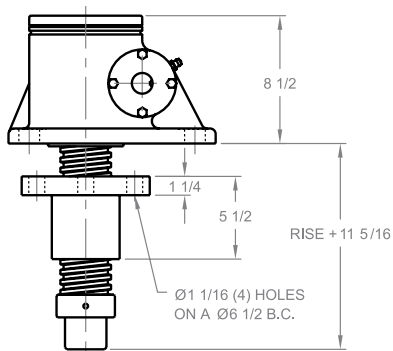

### Typical Plan View

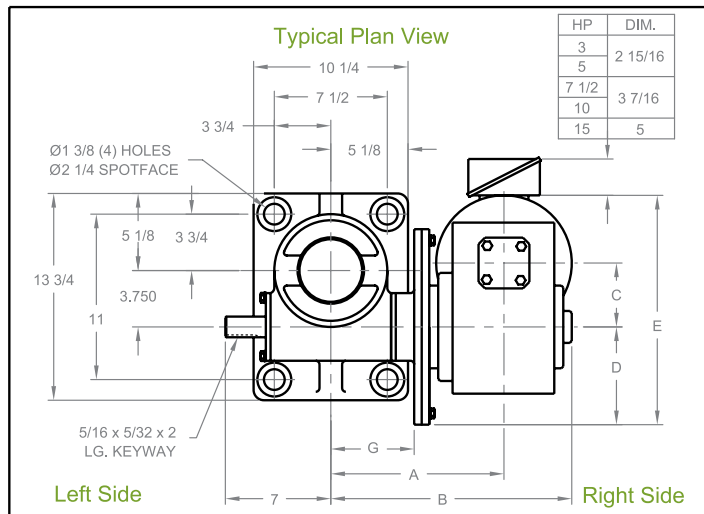

Left Side

Right Side

### Inverted

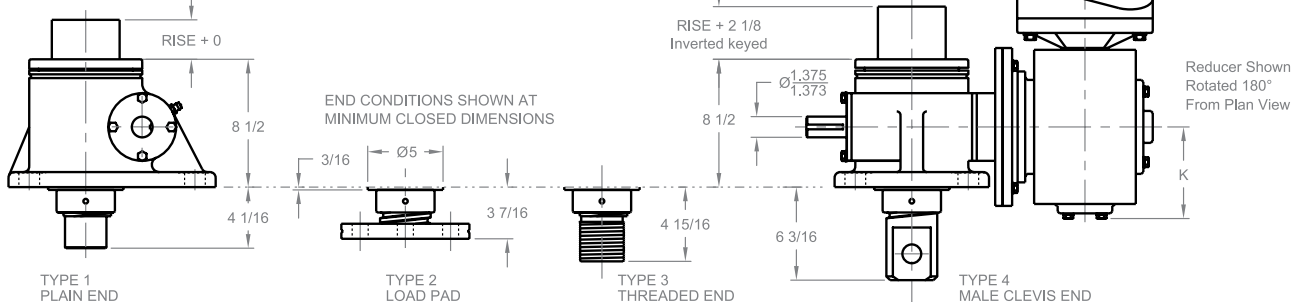

END CONDITIONS SHOWN AT  
MINIMUM CLOSED DIMENSIONS

Reducer Shown  
Rotated 180°  
From Plan View

Note: Drawings are artist's conception — not for certification; dimensions are subject to change without notice.



# MACHINE SCREW ComDRIVES®

## 30 TON - 3 1/2" SCREW

CD 1130 / DCD 1130  
CD 3230 / DCD 3230

### Upright

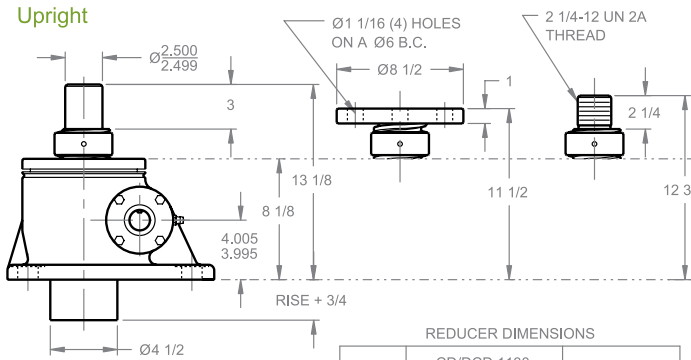

### Upright traveling nut

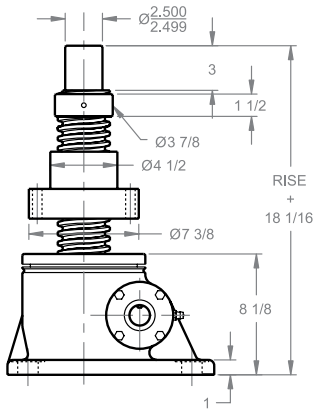

### Inverted traveling nut

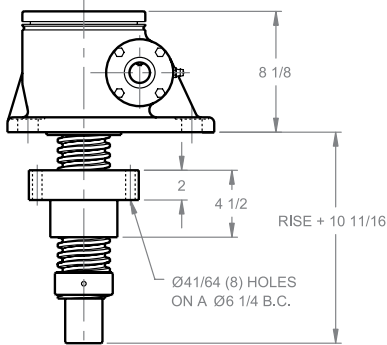

### Inverted

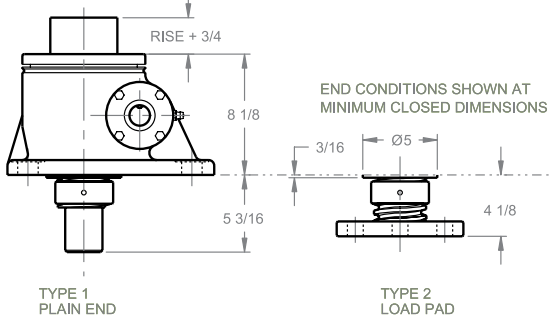

TYPE 1  
PLAIN END

TYPE 2  
LOAD PAD

TYPE 3  
THREADED END

TYPE 4  
MALE CLEVIS END

NOTE: FOR LIFTING CAPACITIES SEE PAGE 49

### REDUCER DIMENSIONS

MODEL	CD/DCD 1130				CD/DCD 3230			
	5:1	10:1	5:1	10:1	5:1	10:1	5:1	10:1
RATIO	5:1	10:1	5:1	10:1	5:1	10:1	5:1	10:1
HP	3	5	5	7 1/2	7 1/2	10	15	15
A	9 17/32	9 31/32	10 1/2	11 19/32	11 19/32	12 3/4	15 1/4	15 1/4
B	13 1/32	13 29/32	14 1/2	16 3/32	16 3/32	18 1/4	21 1/4	21 1/4
C	2 5/8	3 1/4	3 1/4	4 1/4	4 1/4	5 1/4	6 1/2	6 1/2
D	4 7/16	5 1/2	5 1/2	6 1/2	6 1/2	7 1/2	8 1/4	8 1/4
E	11 9/16	12 3/4	12 3/4	15 1/4	15 1/4	18 1/4	21 1/4	21 1/4
F	3 9/16	4 1/2	4 1/2	5 1/4	5 1/4	6 1/2	7 1/2	7 1/2
G	5 1/2	5 1/2	5 1/2	6 1/2	6 1/2	7 1/2	8 1/4	8 1/4
H	0	1/2	1/2	1 1/4	1 1/4	1 1/4	1 1/4	1 1/4
J	4 11/16	6 3/4	6 3/4	7 1/4	7 1/4	8 1/4	9 1/16	9 1/16
K	3 11/32	4 5/16	4 5/16	6 1/8	6 1/8	7 1/4	8 1/4	8 1/4

RISE + 4"  
DOUBLE CLEVIS  
SHOWN 90° FROM  
TRUE POSITION

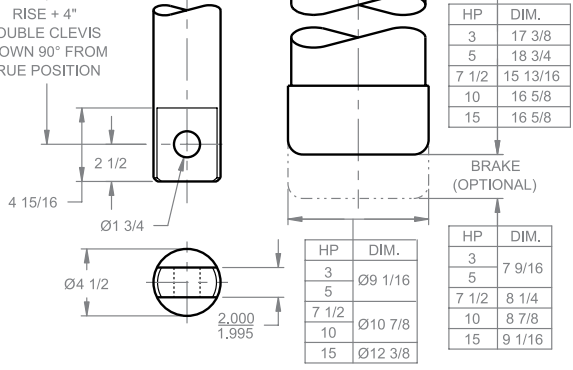

### Typical Plan View

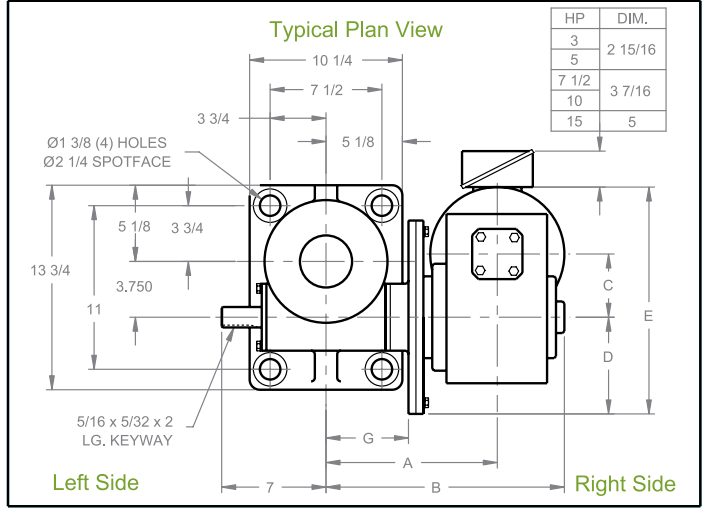

Note: Drawings are artist's conception — not for certification; dimensions are subject to change without notice.

Joyce stainless steel screw jacks are specifically designed for positioning and lifting applications that are located in wet, corrosive or other harsh environments. In most cases, these jacks can be easily retrofitted into applications where non-stainless steel jacks have already been installed.

They are available in 2-ton through 25-ton capacities with either single lead (SWJ) or double lead (DSWJ) lifting screws. SWJ series jacks are self-locking under full lifting capacity. DSWJ series jacks offer increased travel speeds and may require a brake motor or other external locking device to hold position.

- All exposed surfaces and components feature 316 or 17-4 stainless steel construction and bronze (bushings and traveling nut).
- Nitrile rubber seals protect all internal mechanisms.
- Tapered roller or ball thrust bearings provide rugged reliability.

They are available with one of four standard screw ends or special ends to meet your requirements. Double input shafts are standard. An optional anti-backlash feature (page 181) compensates for thread wear, assuring minimum play between lifting screw and wormgear for smooth, precise operation. All jack designs can be fitted with protective boots.

Joyce can customize stainless steel jacks to meet your specifications.

**Stainless steel jacks are widely used in many industries including the following:**

- **Food handling**
- **Paper mill**
- **Printing**
- **Defense**
- **Coastal installations**



# STAINLESS STEEL SCREW JACKS

Joyce offers Stainless Steel Screw Jacks in several designs including:

- Translating
- Keyed for non-rotation
- Keyed for traveling nut (KFTN)
- Double clevis

A guide for ordering is on pages 60 and 61.

# STAINLESS STEEL JACKS ORDERING INFORMATION

**Instructions:** Select a model number from this chart.

2-Ton	2-Ton Reverse Base	5-Ton	10-Ton	15-Ton	20-Ton	25-Ton
SWJ62 SWJ122 SWJ242	RSWJ62 RSWJ122 RSWJ242	SWJ65 SWJ125 SWJ245	SWJ810 SWJ2410	SWJ815 SWJ2415	SWJ820 SWJ2420	SWJ1125 SWJ3225
DSWJ62* DSWJ122* DSWJ242*	DRSWJ62* DRSWJ122* DRSWJ242*	DSWJ65* DSWJ125* DSWJ245*	DSWJ810* DSWJ2410*	DSWJ815* DSWJ2415*	DSWJ820* DSWJ2420*	DSWJ1125* DSWJ3225*

**Important Note:** \*Not self-locking, may lower under load. Brake motors or external locking systems are recommended.

**D:** Double Lead Screw.

**R:** Reverse Base Jack (only available on 2-ton jacks).

(For 25:1 ratio contact Joyce.)

## Sample Part Number: RSWJ62U2S-6.00-STDX-STDX-B

### Jack Configuration

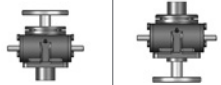

**U=Upright**    **I=Inverted**

### End Conditions

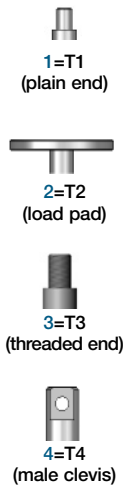

**1=T1**  
(plain end)

**2=T2**  
(load pad)

**3=T3**  
(threaded end)

**4=T4**  
(male clevis)

### Left Side Shaft Code

(see below)

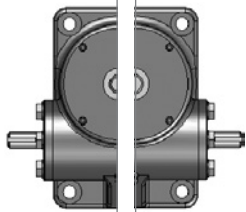

**XXXX=Remove**  
**STDX=Standard**  
**CUST=Custom**

For optional shaft codes, see page 61.

### Right Side Shaft Code

(see below)

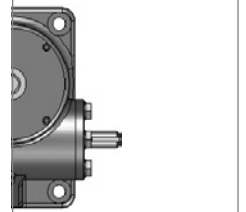

**XXXX=Remove**  
**STDX=Standard**  
**CUST=Custom**

For optional shaft codes, see page 61.

### Additional Options\*

**X=Standard Jack**, no additional options

**S=Additional Specification Required** (comment as necessary)

**Anti-Backlash**  
p. 181

**A=Split Nut**  
**A90=A90 Design**  
**A95=A95 Design**

**Protective Boots**  
pp. 170-173

**B=Protective Boot**  
**D=Dual Protective Boot**

**Finishes** p. 182

**F2=Epoxy Paint**  
**F3=Outdoor Paint Process**

**Motor Options**

**M1=Less Motor**  
**M2=Brake Motor**  
**M3=Single Phase Motor (120VAC)**  
**M4=50Hz Motor**  
**M5=Special Motor**

**Grease/Seals**

**H1=High Temperature Operation**  
**H2=Food Grade**

**Screw Stops**

**ST0=Extending**  
**ST1=Retracting**  
**ST2=Both**

\* Specify as many options as needed

### Stainless Steel Screw Jack Rise

Rise is travel expressed in inches and not the actual screw length.

### Jack Designs



**S=Translating**



**K=Keyed for Non Rotation**



**N=Traveling Nut**



**D=Double Clevis\***



**A=KFTN Trunnion\***  
**T=Trunnion\***

\*Contact Joyce with your requirements.

# STAINLESS STEEL JACKS SHAFT CODES

**Instructions:** Select the appropriate shaft codes for both right and left hand shafts. One shaft code must be specified for each side of the jack.

**Screw Stops (p. 10) and Boots (p. 170-173)**

Stainless steel screw stops are optional on stainless steel jacks. When specified, the closed height of the jack and the protection tube length may be increased.

When boots are added to stainless steel jacks, the closed height of the jack may be increased.

**Mechanical Counters (p.180)**

**CNT0=0.001" Increments**

Note: Contact Joyce for availability and options.



**Hand Wheels (p. 180)**

HW04=4" dia  
 HW06=6" dia  
 HW08=8" dia  
 HW10=10" dia  
 HW12=12" dia



Recommended for self-locking jacks only.

**Geared Potentiometers (p. 175)**

POTA=0-10V  
 POTB=4-20mA  
 POTC=0-10V w/2 switches  
 POTD=4-20mA w/2 switches  
 IP65 rated enclosures



**Encoders (pp. 176-177)**

ENCA=Absolute Encoder 0-10 VDC, programmable  
 ENCB=Absolute Encoder 4-20mA, programmable  
 ENCC=Absolute Encoder CAN Open  
 ENCD=Absolute Encoder SSI  
 ENCS=Stainless Steel Incremental Encoder 1024 PPR  
 ENCX=Incremental Encoder 200 PPR  
 ENCY=Incremental Encoder 1024 PPR



**Motors for Systems and Direct Drives (pp. 178-179)**

- All standard motors are 3-phase, 208-230/460 VAC or 230/460 VAC. Other motor options are available. Specify the appropriate motor size from the chart on the right.
- Refer to the "Additional Options" chart on the preceding page as needed.
- Brake motors (M2) are recommended for jacks that are not self locking and jacks with double lead screws.
- If the motor frequency will be varied to provide a "soft" start, an inverter duty motor may be required.

Motors	
Size	Code
1/4 HP	K
1/3 HP	A
1/2 HP	B
3/4 HP	C
1 HP	D
1-1/2 HP	E
2 HP	F
3 HP	L
5 HP	G
7-1/2 HP	H
10 HP	I
15 HP	J

**Motor Mounts (pp. 178-179)**

Ordering Example: **MMA A**

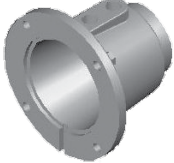

MMA=56C  
 MMB=140TC  
 MMC=180TC  
 MMD=210TC

Motor code from chart at left  
 For servo motor mounts see p. 178  
 Standard motor adapters are aluminum.

**Mechanical Limit Switches (p. 174)**

Ordering Example: **LA13**

Models		Number of DPDT Switches (see p. 174)	Available Positions							
Model	Code		1	2*	3	4	5	6*	7	8
LS7-402	LI	NOTE: Will always be 0 for LS7 models								
LS8-402	LA									
LS8-404	LB									

• 2, 5, 10, 15, and 20 ton stainless steel jacks are available with positions #1, #3, and #5.  
 • 25 ton stainless steel jacks are available with positions # 1, #4, #7, and #8.  
 \*These positions are not standard. Contact Joyce with your requirements.  
 Note: Limit Switch housings are not stainless steel. Choose STEEL IT® epoxy paint option instead.

# STAINLESS STEEL JACKS COLUMN LOADING

Stainless Steel Screw Jack Column Loading Chart

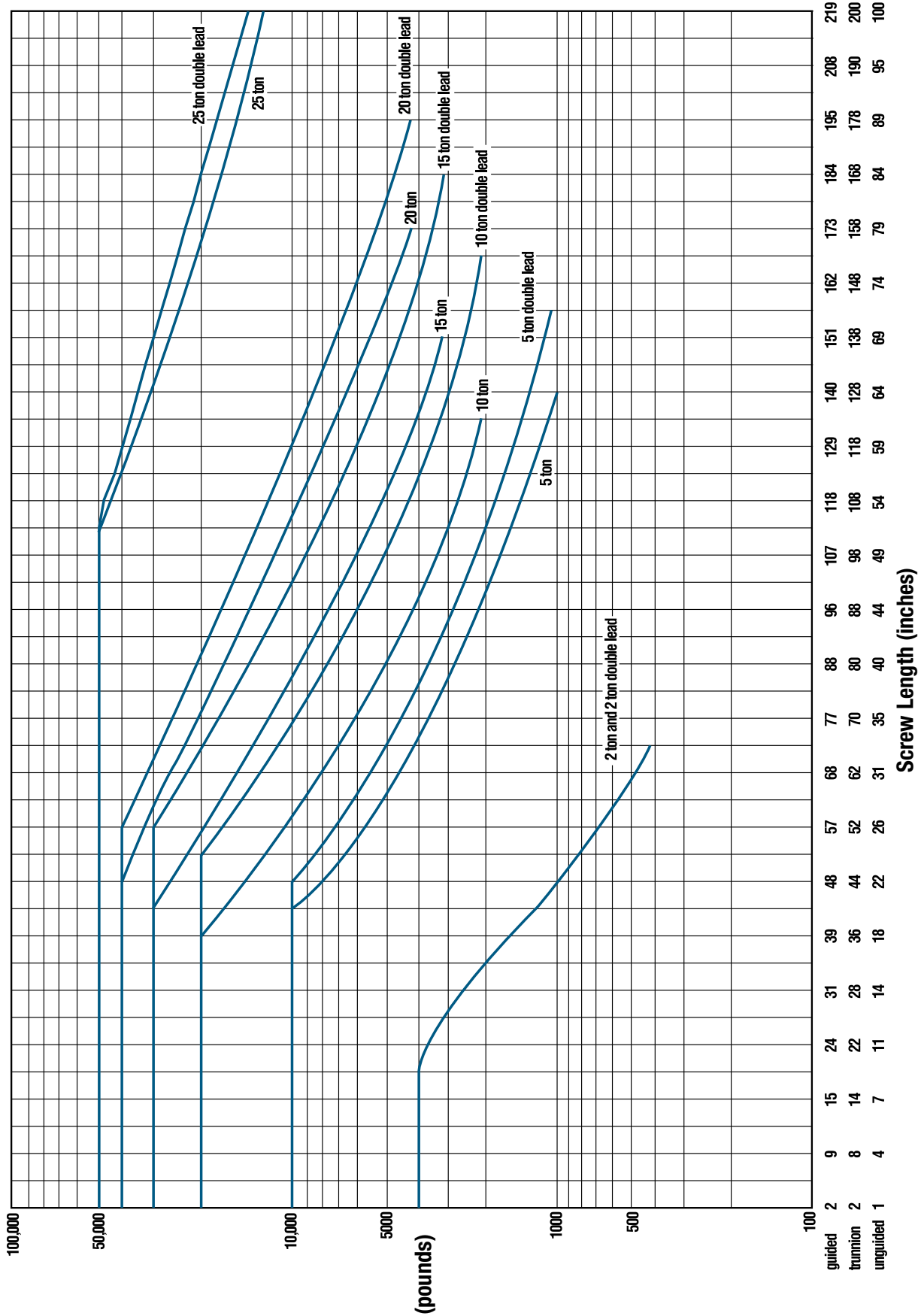

This chart includes a 2:1 Factor-of-Safety based on the Euler-Johnson equation for column loading (Oberg, Erik et al: Machinery's Handbook, 24th Edition. c. 1992 Industrial Press Inc.)  
The horizontal portion of each line represents the jack's maximum dynamic capacity. Under static conditions, these lines can be exceeded. Please contact factory for assistance.

# STAINLESS STEEL JACKS SPECIFICATIONS

Model	Capacity	Screw Diameter (inches)	Thread Pitch/Lead	Worm Gear Ratio	Worm Shaft Turns for 1" Travel	Tare Torque (Inch Lbs.)	Starting Torque (Inch Lbs.)	Operating Torque (Inch Lbs.)	Efficiency Rating % Approx	Screw Torque (Inch Lbs.)	Basic Jack Weight (Lbs.)	Jack Weight per Inch Travel (Lbs.)
(R)SWJ62	2 ton	1	.250 pitch ACME 2C	6:1	24	6	.041W*	.028W* @ 500 RPM	24.2	.098W*	15	0.3
(R)SWJ122				12:1	48		.025W*	.015W* @ 500 RPM	22.0			
(R)SWJ242				24:1	96		.018W*	.009W* @ 500 RPM	18.3			
D(R)SWJ62			6:1	12	.057W*		.039W* @ 500 RPM	33.7				
D(R)SWJ122			12:1	24	.035W*		.022W* @ 500 RPM	30.5				
D(R)SWJ242			24:1	48	.025W*		.013W* @ 500 RPM	25.4				
SWJ65	5 ton	1 1/2	.375 pitch STUB ACME	6:1	16	15	.065W*	.044W* @ 300 RPM	23.0	.151W*	32	0.7
SWJ125				12:1	32		.041W*	.025W* @ 300 RPM	20.6			
SWJ245				24:1	64		.029W*	.015W* @ 300 RPM	16.7			
DSWJ65			6:1	12	.072W*		.050W* @ 300 RPM	26.8				
DSWJ125			12:1	24	.045W*		.028W* @ 300 RPM	23.9				
DSWJ245			24:1	48	.033W*		.017W* @ 300 RPM	19.6				
SWJ810	10 ton	2	.500 pitch ACME 2C	8:1	16	30	.061W*	.043W* @ 200 RPM	23.1	.195W*	43	1.3
SWJ2410				24:1	48		.030W*	.018W* @ 200 RPM	18.8			
DSWJ810			8:1	12	.070W*		.062W* @ 200 RPM	31.9	.228W*			
DSWJ2410			24:1	36	.035W*		.026W* @ 200 RPM	25.9				
SWJ815	15 ton	2 1/4	.500 pitch ACME 2C	8:1	16	45	.069W*	.047W* @ 200 RPM	21.1	.210W*	59	1.4
SWJ2415				24:1	48		.036W*	.020W* @ 200 RPM	16.6			
DSWJ815			8:1	12	.079W*		.058W* @ 200 RPM	34.4	.244W*			
DSWJ2415			24:1	36	.041W*		.025W* @ 200 RPM	27				
SWJ820	20 ton	2 1/2	.500 pitch ACME 2C	8:1	16	60	.075W*	.051W* @ 200 RPM	19.6	.227W*	77	1.9
SWJ2420				24:1	48		.039W*	.022W* @ 200 RPM	15.4			
DSWJ820			8:1	10.67	.088W*		.061W* @ 200 RPM	24.5	.272W*			
DSWJ2420			24:1	32	.046W*		.026W* @ 200 RPM	19.3				
SWJ1125	25 ton	3 3/8	.666 pitch STUB ACME	11:1	16	75	.088W*	.055W* @ 200 RPM	18.3	.313W*	164	3.1
SWJ3225				32:1	48		.053W*	.025W* @ 200 RPM	13.5			
DSWJ1125			11:1	9.5	.106W*		.067W* @ 200 RPM	25.1	.384W*			
DSWJ3225			32:1	28.5	.063W*		.030W* @ 200 RPM	18.6				

**Important Note:** Series DSWJ models may lower under load. Brake motors or external locking systems are recommended.

(R): Reverse Base Jack.

\*W: Load in pounds.

**Tare Torque:** Initial torque to overcome seal and normal assembly drag. This value must be added to starting torque or operating torque values.

**Starting Torque:** Torque value required to start moving the rated load (dissipates to operating torque values once the load begins moving).

**Operating Torque:** Torque required to continuously raise a given load at the input RPM listed.

**Note:** If your actual input RPM is 20% higher or lower than the listed RPM, please refer to JAX® Online to determine actual torque values at your RPM.

**Screw Torque:** Torque required to resist screw rotation (Translating Design Jacks) and traveling nut rotation (Keyed for Traveling Nut Design Jacks).

**Lead:** The distance traveled axially in one rotation of the lifting screw.

**Pitch:** The distance from a point on a screw thread to a corresponding point on the next thread, measured axially.

**Note:** This chart is provided for reference only. For specific information such as column loading, allowable continuous travel and other performance factors please refer to JAX® Online software or contact Joyce.

# STAINLESS STEEL JACKS

## 2 TON - 1" SCREW

SWJ 62 / DSWJ 62  
 SWJ 122 / DSWJ 122  
 SWJ 242 / DSWJ 242

### Upright

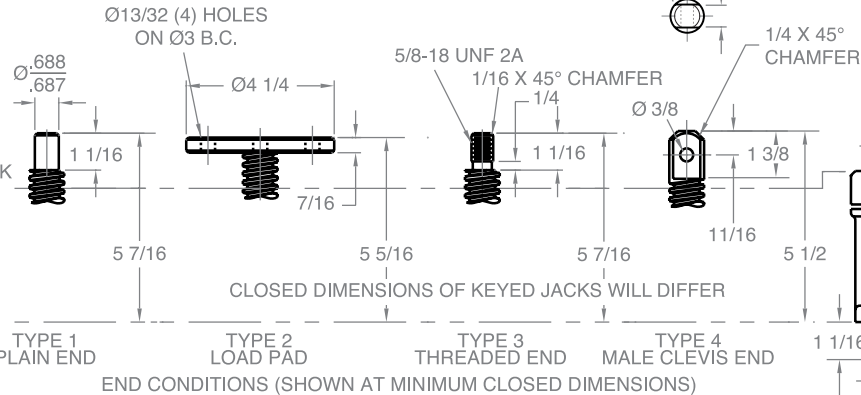
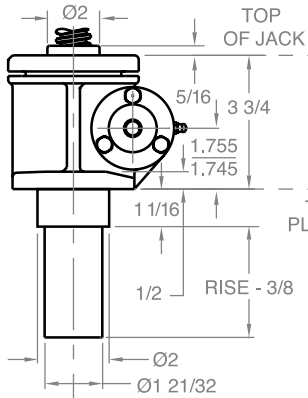

### Upright keyed

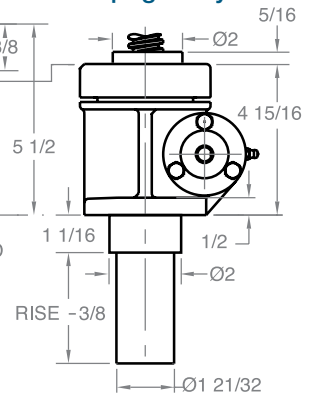

### Typical Plan View

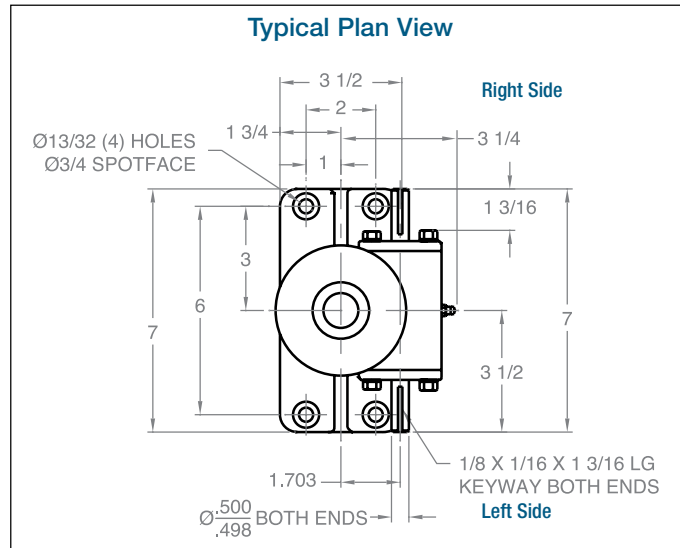

### Upright traveling nut

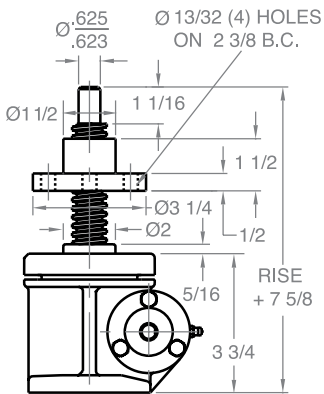

### Inverted traveling nut

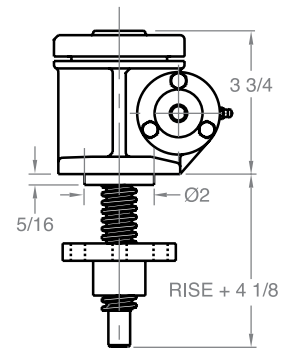

### Double Clevis

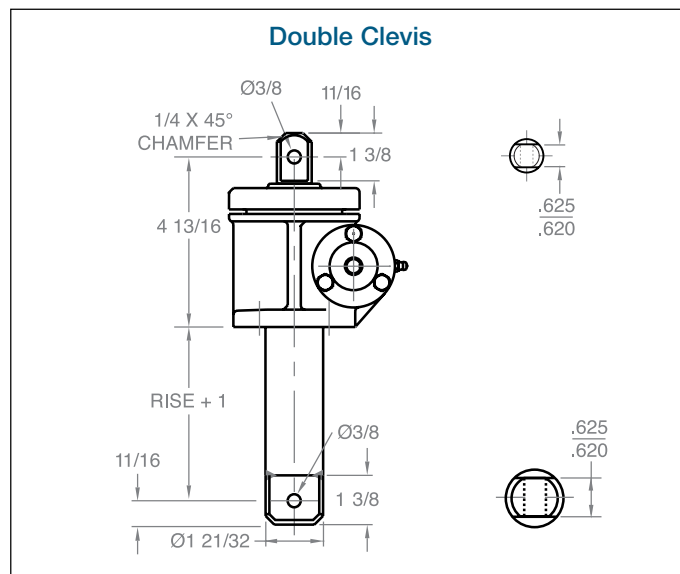

### Inverted

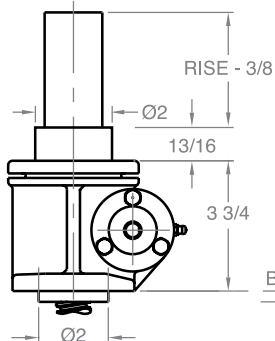

### Inverted keyed

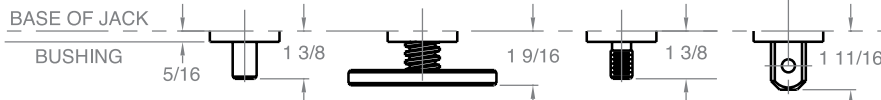
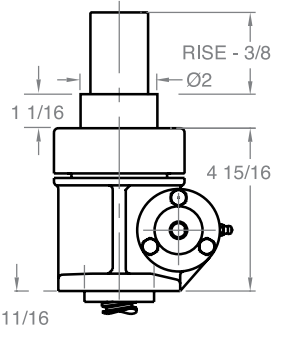

Note: Drawings are artist's conception — not for certification; dimensions are subject to change without notice.



# STAINLESS STEEL JACKS

## 2 TON REVERSE BASE - 1" SCREW

RSWJ 62 / DRSWJ 62  
 RSWJ 122 / DRSWJ 122  
 RSWJ 242 / DRSWJ 242

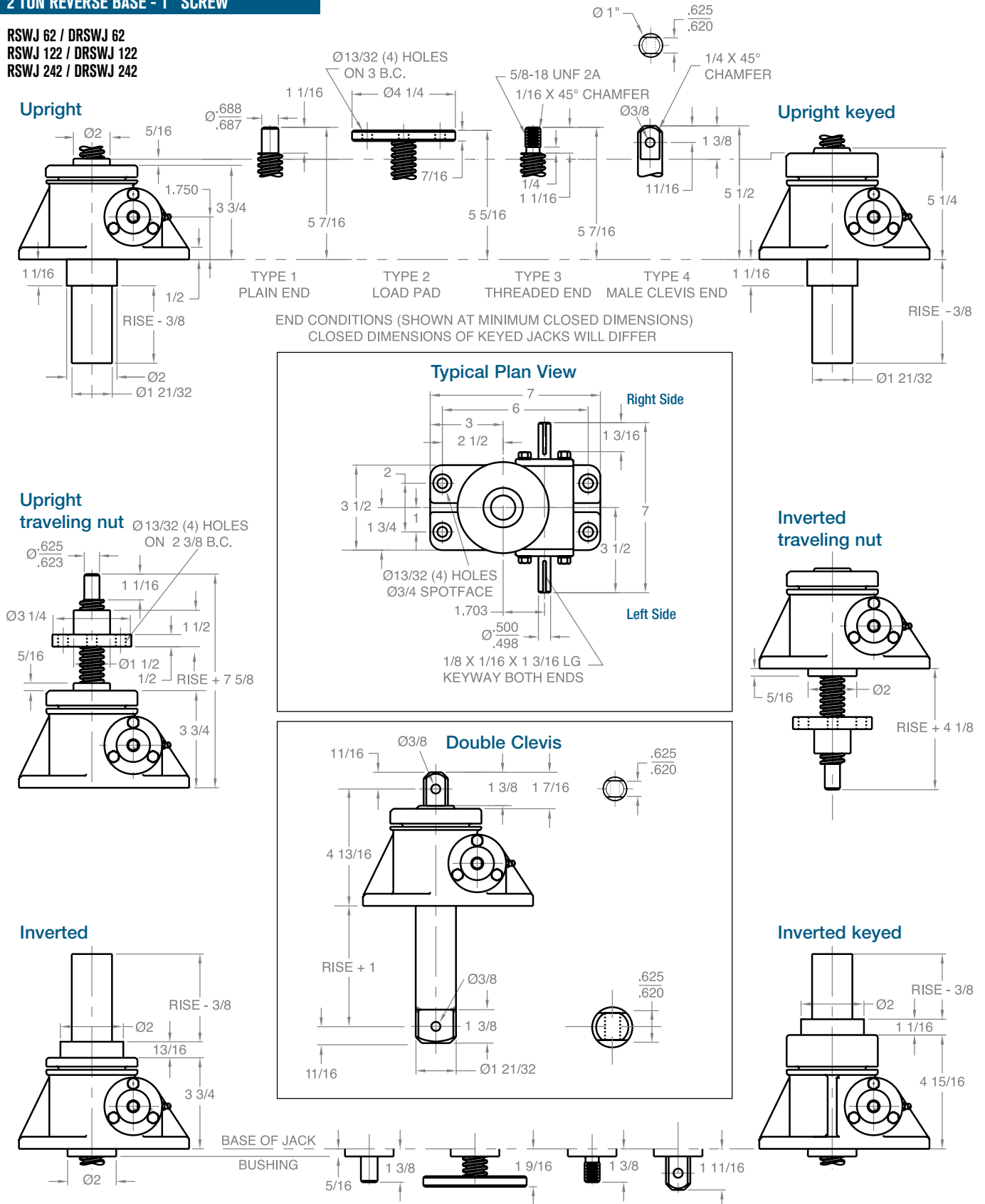

Note: Drawings are artist's conception — not for certification; dimensions are subject to change without notice.

# STAINLESS STEEL JACKS

5 TON - 1 1/2" SCREW

SWJ 65 / DSWJ 65  
 SWJ 125 / DSWJ 125  
 SWJ 245 / DSWJ 245

## Upright

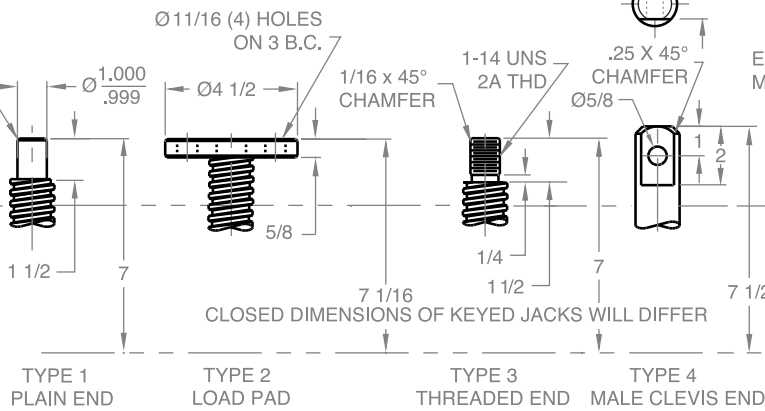
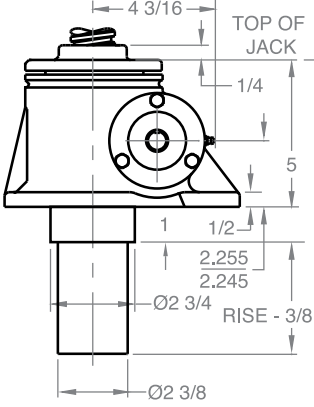

END CONDITIONS (SHOWN AT MINIMUM CLOSED POSITION)

## Upright keyed

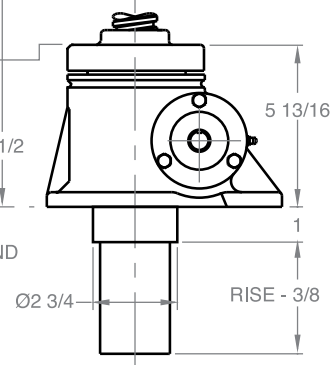

## Upright traveling nut

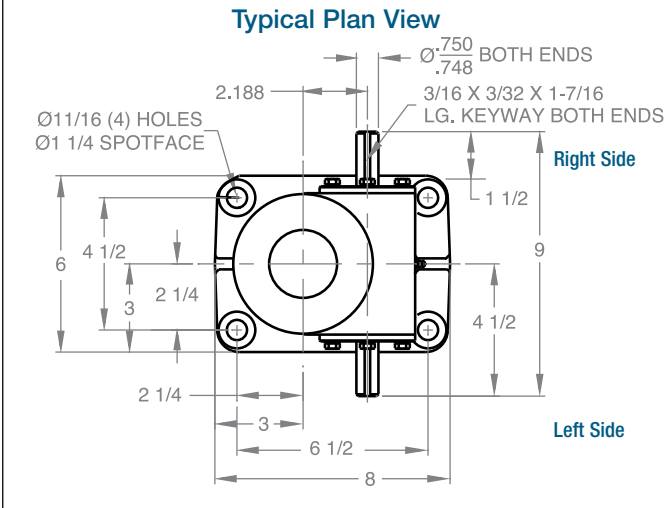
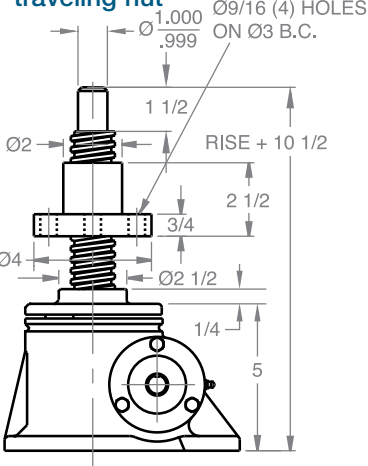

## Inverted traveling nut

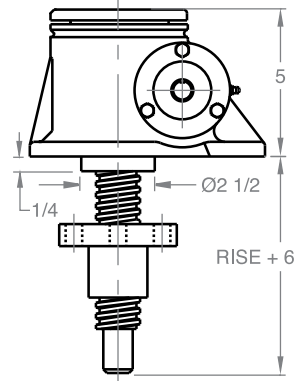

## Inverted

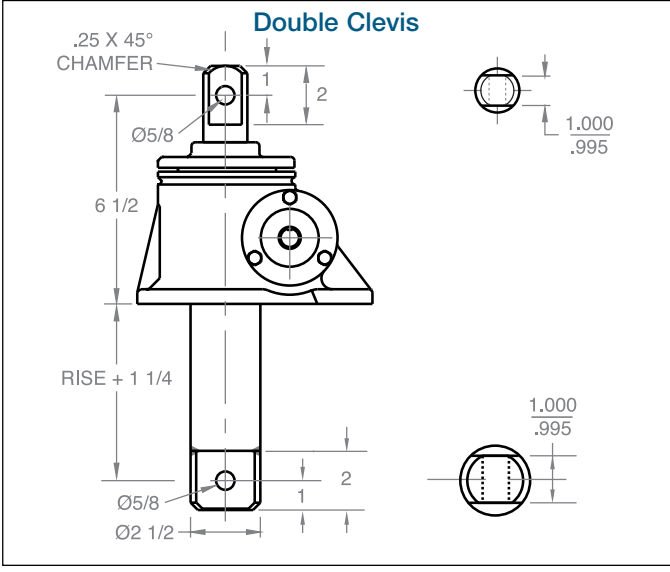
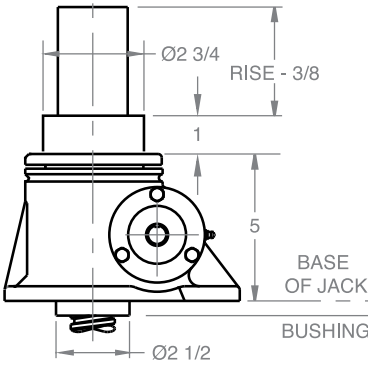

## Inverted keyed

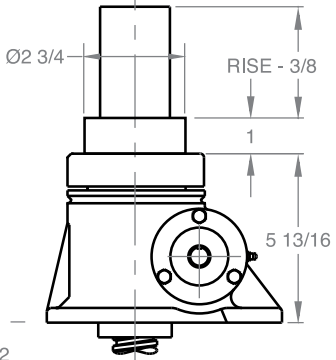

Note: Drawings are artist's conception — not for certification; dimensions are subject to change without notice.

# STAINLESS STEEL JACKS

## 10 TON - 2" SCREW

SWJ 810 / SWJ 2410  
DSWJ 810 / DSWJ 2410

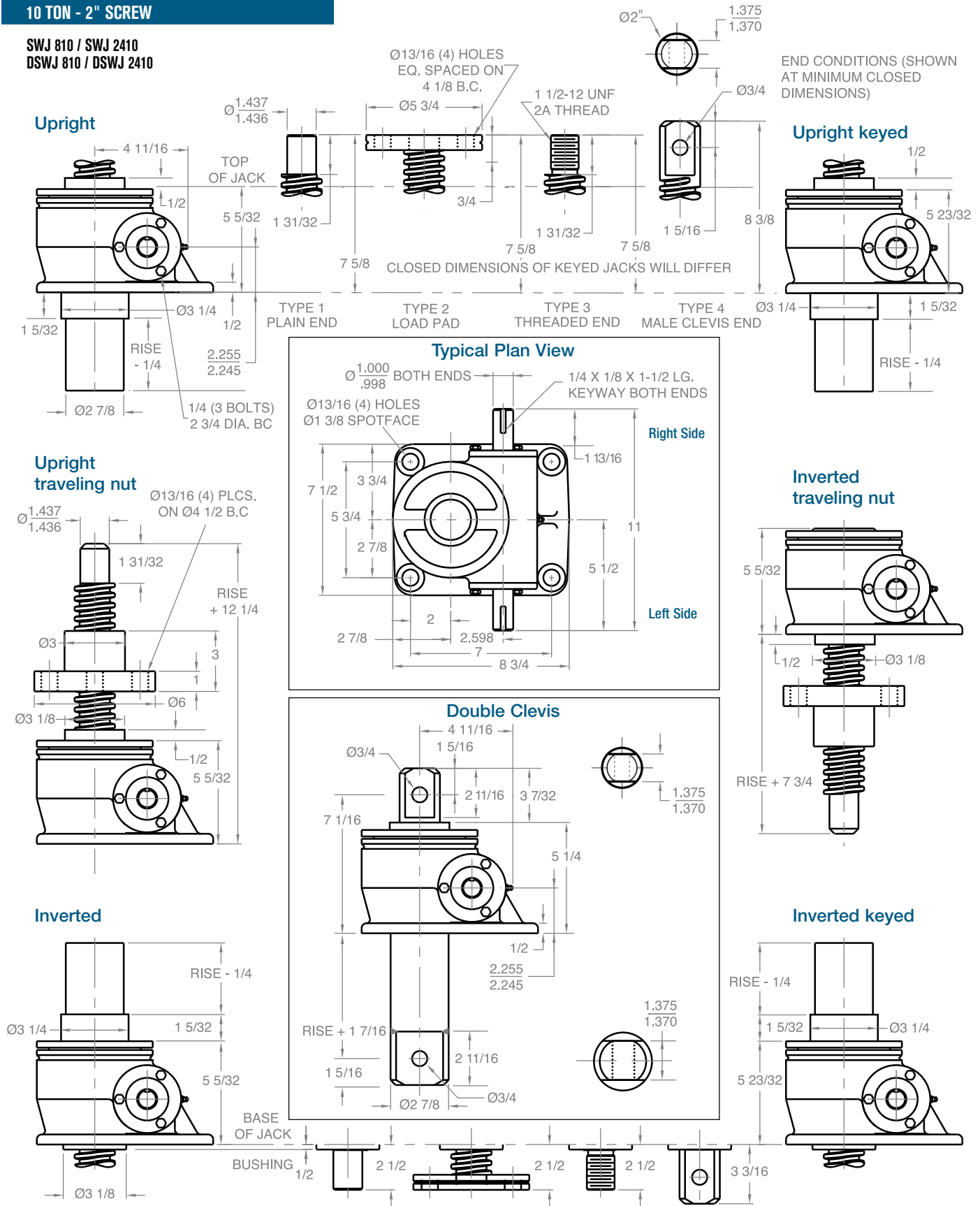

Note: Drawings are artist's conception — not for certification; dimensions are subject to change without notice.

# STAINLESS STEEL JACKS

## 15 TON - 2 1/4" SCREW

SWJ 815 / SWJ 2415  
DSWJ 815 / DSWJ 2415

END CONDITIONS  
(SHOWN AT MINIMUM  
CLOSED DIMENSIONS)

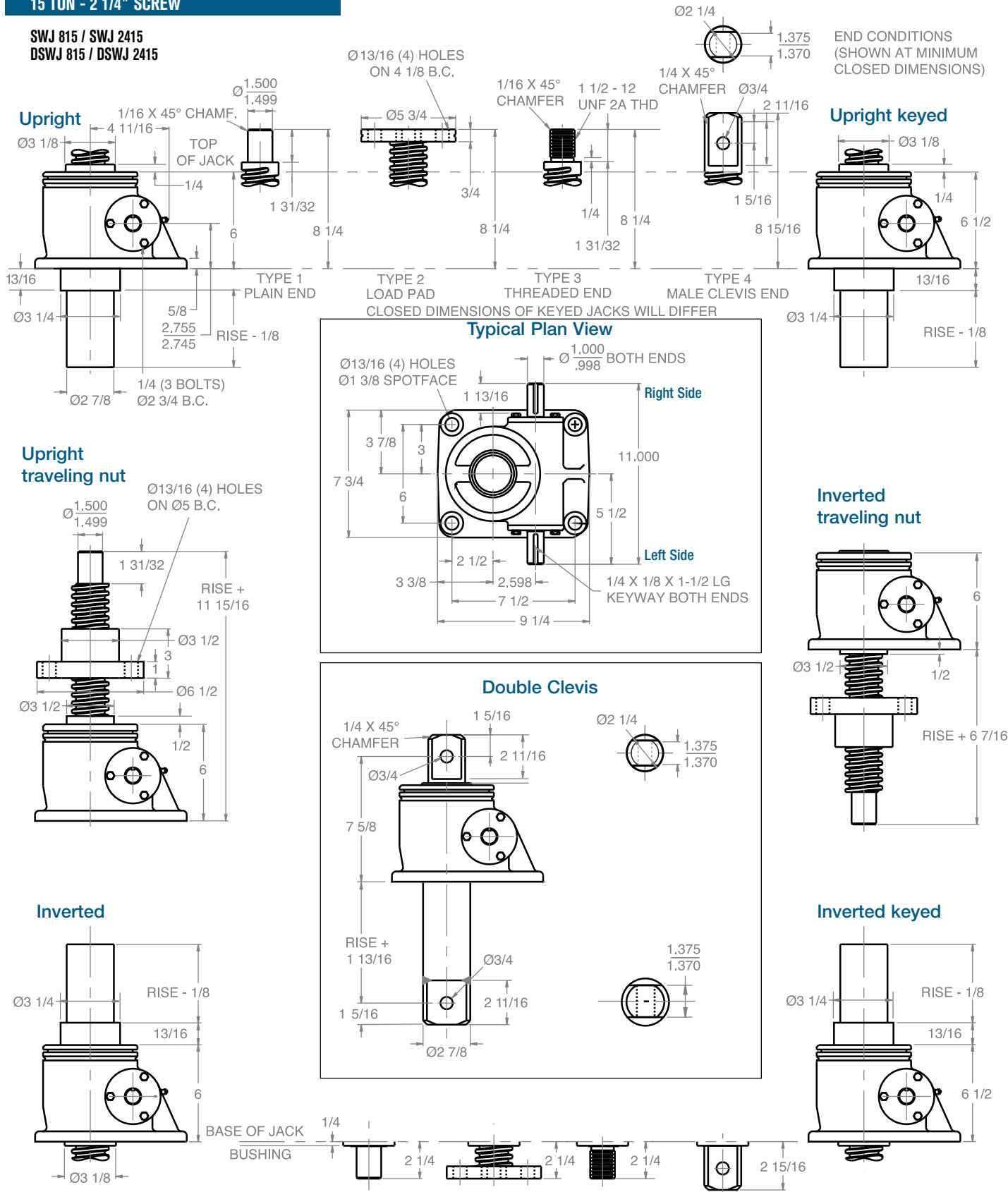

Note: Drawings are artist's conception — not for certification; dimensions are subject to change without notice.

# STAINLESS STEEL JACKS

## 20 TON - 2 1/2" SCREW

SWJ 820 / SWJ 2420  
DSWJ 820 / DSWJ 2420

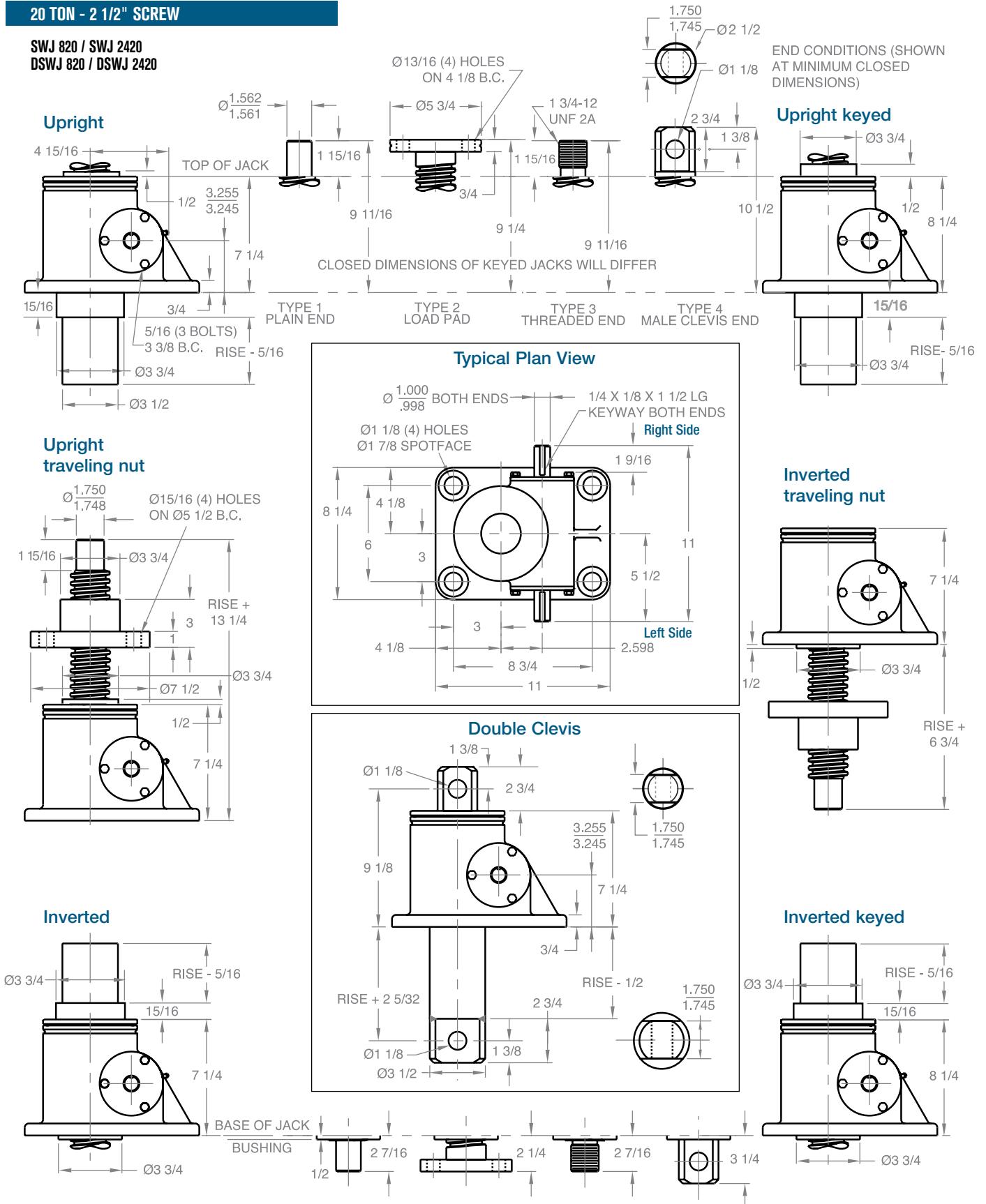

Note: Drawings are artist's conception — not for certification; dimensions are subject to change without notice.

# STAINLESS STEEL JACKS

## 25 TON - 3 3/8" SCREW

SWJ 1125 / SWJ 3225  
DSWJ 1125 / DSWJ 3225

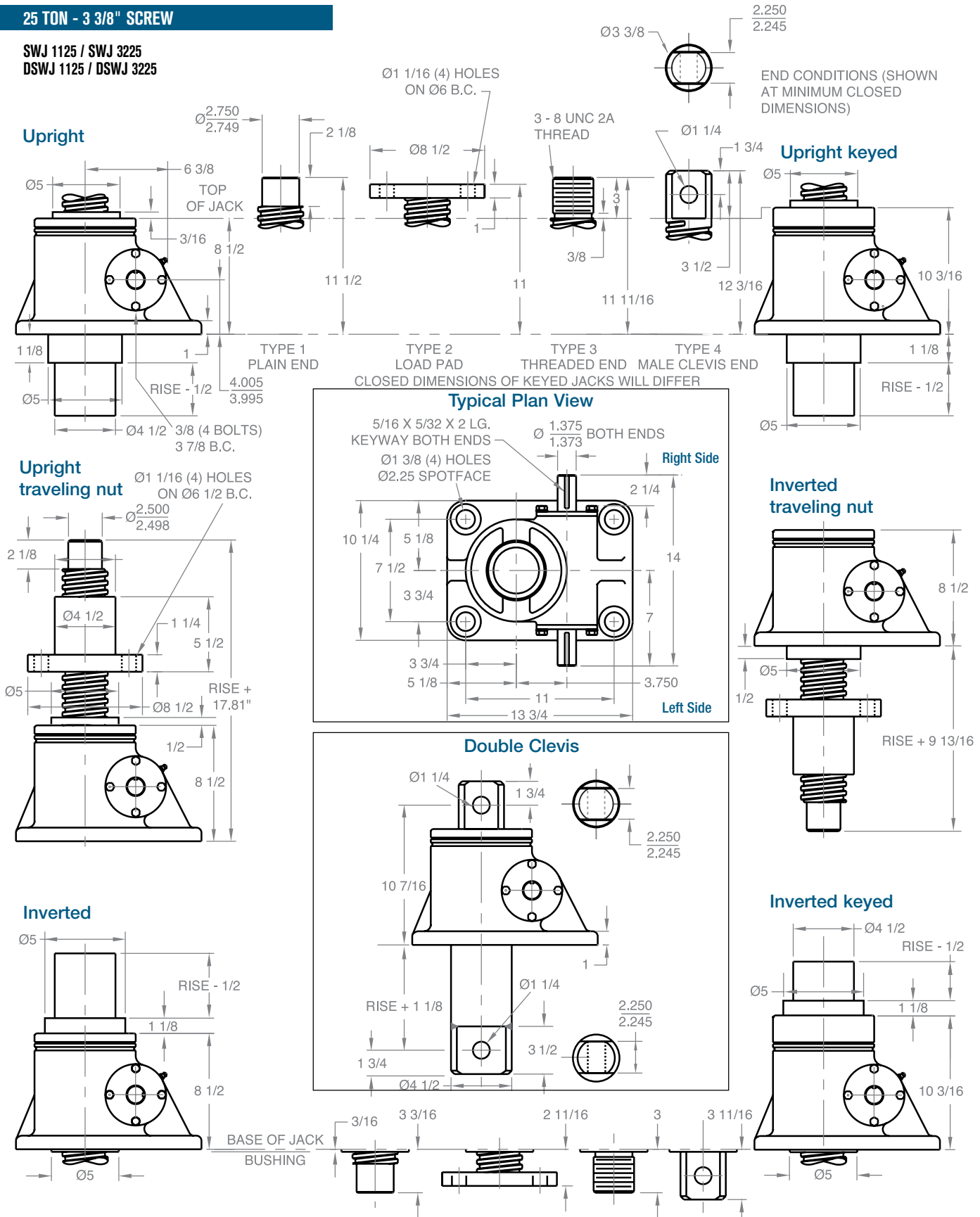

Note: Drawings are artist's conception — not for certification; dimensions are subject to change without notice.

# METRIC SCREW JACKS

Joyce offers Metric Screw Jacks in several designs including:

- Translating
- Keyed for non-rotation
- Keyed for traveling nut (KFTN)
- Double clevis

A guide for ordering is on pages 72 and 73.

Joyce metric screw jacks, series MWJ, are specifically designed for positioning and lifting applications that must be fully metric. These jacks are commonly used in OEM machinery manufactured in the U.S. and shipped to other countries around the world. They are fully interchangeable with several European products.

Metric screw jacks are available in four capacities: 10 kN, 25 kN, 50 kN, and 100 kN. MWJ screw jacks feature:

- Industry standard metric (trapezoidal) lifting screw diameters and pitches.
- Fully metric mounting hole locations, diameters and fasteners.
- Alloy steel worm shafts and bronze wormgears and traveling nuts.
- Tapered roller or ball thrust bearings provide rugged reliability.

Both upright and inverted configurations of these precision jacks operate at full capacity whether the load is in tension or compression. All MWJ jacks are self-locking under full capacity.

Metric screw jacks are available with one of four standard screw ends or special ends to meet your requirements. Double input shafts are standard. An optional anti-backlash feature (page 181) compensates for thread wear, assuring minimum play between lifting screw and wormgear for smooth, precise operation. All jack designs can be fitted with protective boots.

Joyce can customize metric screw jacks to meet your specifications.



# METRIC SCREW JACKS ORDERING INFORMATION

Instructions: Select a model number from this chart.

10 kN	25 kN	50 kN	100 kN
MWJ51 MWJ201	MWJ62.5 MWJ122.5 MWJ242.5	MWJ65 MWJ125 MWJ245	MWJ810 MWJ2410

Sample Part Number: **MWJ65U2S-300-STDX-STDX-B**

**Jack Configuration**

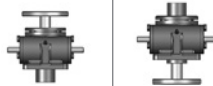

U=Upright I=Inverted

**End Conditions**



1=T1 (plain end)  
2=T2 (load pad)  
3=T3 (threaded end)  
4=T4 (male clevis)

**Left Side Shaft Code**  
(see below)

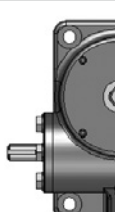

XXXX=Remove  
STDX=Standard  
CUST=Custom  
For optional shaft codes, see page 73.

**Right Side Shaft Code**  
(see below)



XXXX=Remove  
STDX=Standard  
CUST=Custom  
For optional shaft codes, see page 73.

**Additional Options\***

X=Standard Jack, no additional options

S=Additional Specification Required (comment as necessary)

**Anti-Backlash**  
p. 181  
A=Split Nut  
A90=A90 Design  
A95=A95 Design

**Protective Boots**  
pp. 170-173  
B=Protective Boot  
D=Dual Protective Boot

**Finishes** p. 182  
F1=Do Not Paint  
F2=Epoxy Paint  
F3=Outdoor Paint Process

**Motor Options**  
M1=Less Motor  
M2=Brake Motor  
M3=Single Phase Motor (120VAC)  
M4=50Hz Motor  
M5=Special Motor

**Grease/Seals**  
H1=High Temperature Operation  
H2=Food Grade

**Screw Stops**  
ST0=Extending  
ST1=Retracting  
ST2=Both

\* Specify as many options as needed

**Metric Screw Jack Rise**  
Rise is travel expressed in millimeters and not the actual screw length.

**Jack Designs**



S=Translating    K=Keyed for Non Rotation    N=Traveling Nut    D=Double Clevis\*    A=KFTN Trunnion\*  
T=Trunnion\*

\*Contact Joyce with your requirements.



# METRIC SCREW JACKS SHAFT CODES

**Instructions:** Select the appropriate shaft codes for both right and left hand shafts. One shaft code must be specified for each side of the jack.

<b>Screw Stops (p. 10) and Boots (pp. 170-173)</b>	Screw stops are optional on metric screw jacks. When specified, the closed height of the jack and the protection tube length may be increased. When boots are added to metric jacks, the closed height of the jack may be increased.	<b>Mechanical Counters (p. 180)</b>	<b>CNT0</b> =0.025 mm increments Note: Contact Joyce for availability and options.	
--	---	-------------------------------------	---	---

**Hand Wheels (p. 180)**

**HW04**=4" dia.(102mm)  
**HW06**=6" dia.(152mm)  
**HW08**=8" dia.(203mm)  
**HW10**=10" dia.(254mm)  
**HW12**=12" dia.(305mm)

 Recommended for self-locking jacks only.

**Geared Potentiometers (p. 175)**

**POTA**=0-10V  
**POTB**=4-20mA  
**POTC**=0-10V w/2 switches  
**POTD**=4-20mA w/2 switches  
 IP65 rated enclosures



**Encoders (pp. 176-177)**

**ENCA**=Absolute Encoder 0-10 VDC, programmable  
**ENCB**=Absolute Encoder 4-20mA, programmable  
**ENCC**=Absolute Encoder CAN Open  
**ENCD**=Absolute Encoder SSI  
**ENCS**=Stainless Steel Incremental Encoder 1024 PPR  
**ENCX**=Incremental Encoder 200 PPR  
**ENCY**=Incremental Encoder 1024 PPR



**Motors for Systems and Direct Drives (pp. 178-179)**

- All standard motors are 3-phase, 208-230/460 VAC or 230/460 VAC. Other motor options are available. Specify the appropriate motor size from the chart on the right.
- Refer to the "Additional Options" chart on the preceding page as needed.
- If the motor frequency will be varied to provide a "soft" start, an inverter duty motor may be required.
- International voltage motors are available.

Motors	
Size	Code
1/4 HP	<b>K</b>
1/3 HP	<b>A</b>
1/2 HP	<b>B</b>
3/4 HP	<b>C</b>
1 HP	<b>D</b>
1-1/2 HP	<b>E</b>
2 HP	<b>F</b>
3 HP	<b>L</b>
5 HP	<b>G</b>

**Motor Mounts (pp. 178-179)**

Ordering Example:  
**MMA A**



























**MMA**=56C Motor code from chart at left  
**MMB**=140TC  
**MMC**=180TC For servo motor mounts see p. 178  
**MMD**=210TC

- Standard motor adapters are aluminum.
- Motor adapters for many IEC motors are available as an option.

**Mechanical Limit Switches (p. 174)**

Ordering Example: **LA13**

Models		Number of DPDT Switches (see p. 174)	Available Positions							
Model	Code		1	2*	3	4*	5	6*	7*	8*
LS7-402	<b>LI</b>	NOTE: Will always be 0 for LS7 models								
LS8-402	<b>LA</b>									
LS8-404	<b>LB</b>									

\*25 kN, 50 kN, and 100 kN metric jacks are available with positions #1, #3, and #5.  
 \*These positions are not standard. Contact Joyce with your requirements.

# METRIC SCREW JACKS COLUMN LOADING

Metric Screw Jacks Column Loading Chart

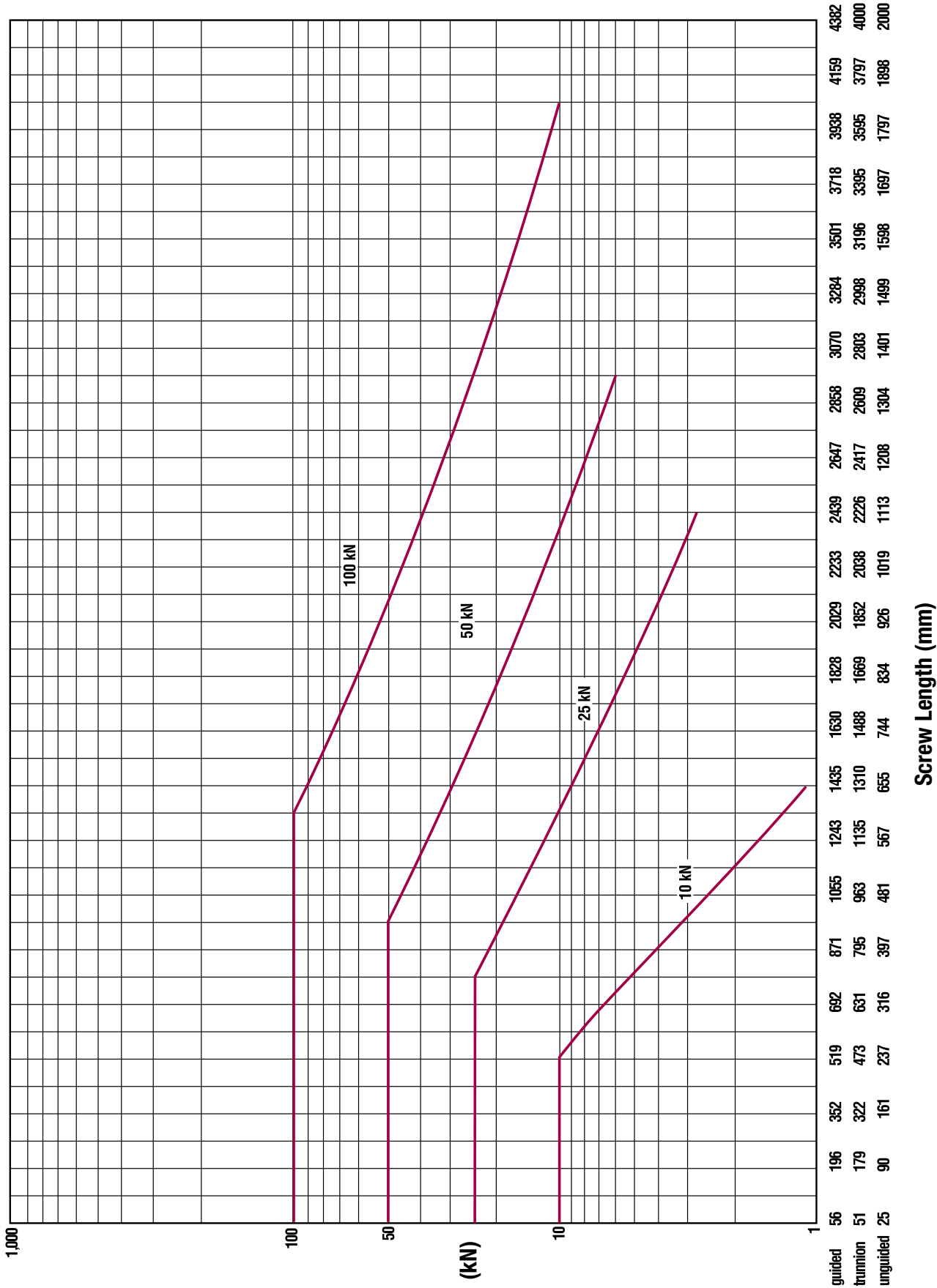

This chart includes a 2:1 Factor-of-Safety based on the Euler-Johnson equation for column loading. The horizontal portion of each line represents the jack's maximum static capacity. Under static conditions, these lines can be exceeded. Please contact the factory for assistance.

# METRIC SCREW JACKS SPECIFICATIONS

Model	Capacity	Screw Diameter (mm)	Thread Pitch/Lead	Worm Gear Ratio	Worm Shaft Turns for 1mm Travel	Tare Torque (Nm)	Starting Torque (Nm)	Operating Torque (Nm)	Efficiency Rating % Approx.	Screw Torque (Nm)	Basic Jack Weight (Kg)	Screw Weight (Kg) per 25mm Travel
MWJ51	10kN	20	5mm	5:1	1	0.33	.95W*	.70W* @ 500 RPM	22.7	2W*	2.7	0.14
MWJ201				20:1	4		.41W*	.23W* @ 500 RPM	17.0			
MWJ62.5	25kN	30	6mm	6:1	1	0.67	1.01W*	.81W* @ 500 RPM	19.6	3W*	6.8	0.18
MWJ122.5				12:1	2		.62W*	.45W* @ 500 RPM	17.8			
MWJ242.5				24:1	4		.44W*	.27W* @ 500 RPM	14.7			
MWJ65	50kN	40	9mm	6:1	0.67	1.13	1.64W*	1.14W* @ 300 RPM	20.9	4W*	14.5	0.32
MWJ125				12:1	1.33		1.03W*	.64W* @ 300 RPM	18.7			
MWJ245				24:1	2.67		.74W*	.39W* @ 300 RPM	15.2			
MWJ810	100kN	55	12mm	8:1	0.67	2.26	1.53W*	1.18W* @ 200 RPM	20.2	5W*	19.5	0.59
MWJ2410				24:1	2		.76W*	.49W* @ 200 RPM	16.1			

\*W: Load in kN.

**Tare Torque:** Initial torque to overcome seal and normal assembly drag. This value must be added to starting torque or operating torque values.

**Starting Torque:** Torque value required to start moving a given load (dissipates to operating torque values once the load begins moving).

**Operating Torque:** Torque required to continuously raise a given load at the input RPM listed.

**Screw Torque:** Torque required to resist screw rotation (Translating Design Jacks) and traveling nut rotation (Keyed for Traveling Nut Design Jacks).

**Lead:** The distance traveled axially in one rotation of the lifting screw.

**Pitch:** The distance from a point on a screw thread to a corresponding point on the next thread measured axially.

**Note:** This chart is provided for reference only. For specific information such as column loading allowable continuous travel and other performance factors please contact Joyce/Dayton.

# METRIC SCREW JACKS

10kN - 20mm SCREW

MWJ 51  
MWJ 201

Upright

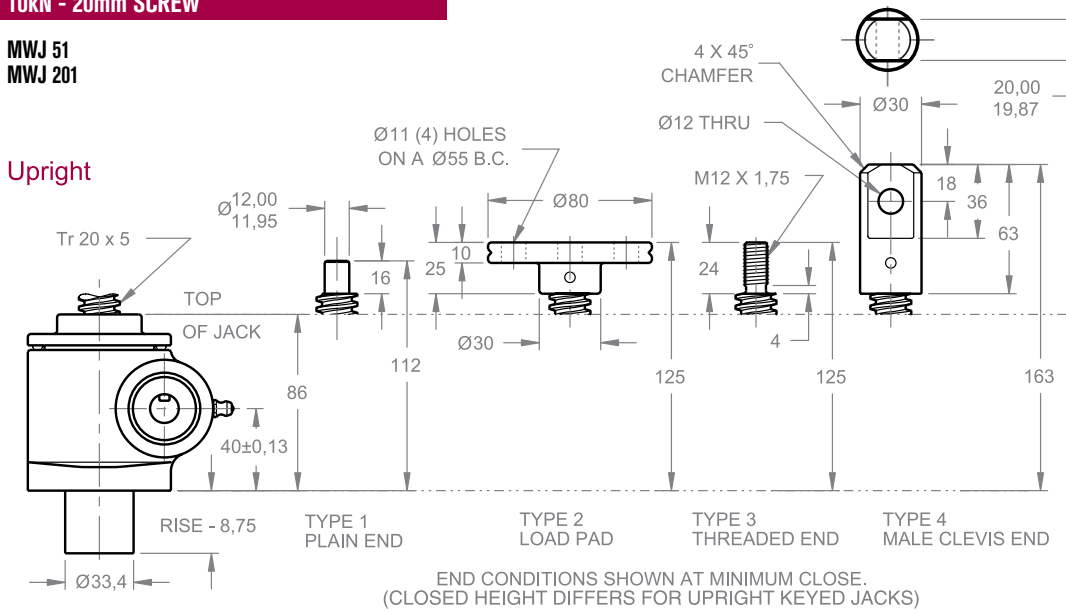

Upright keyed

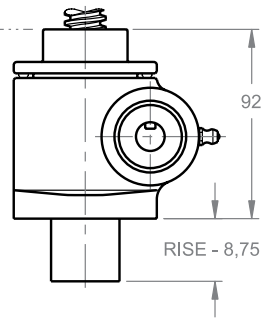

Upright traveling nut

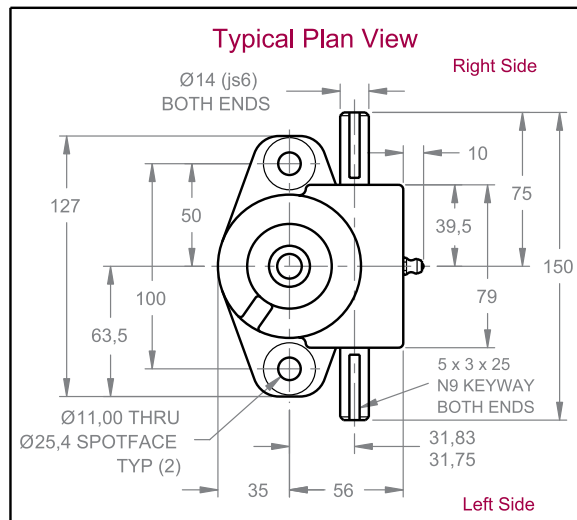
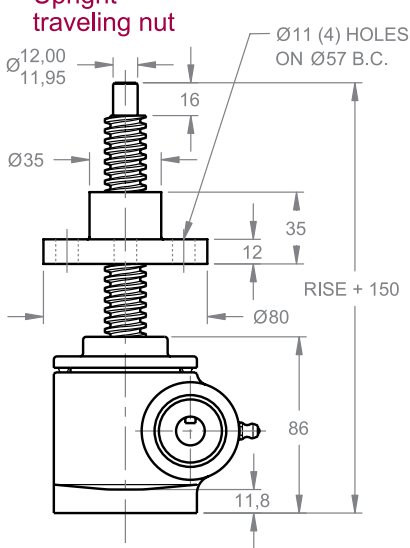

Inverted traveling nut

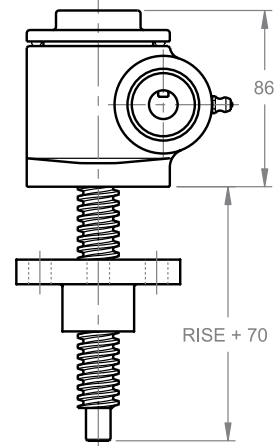

Inverted

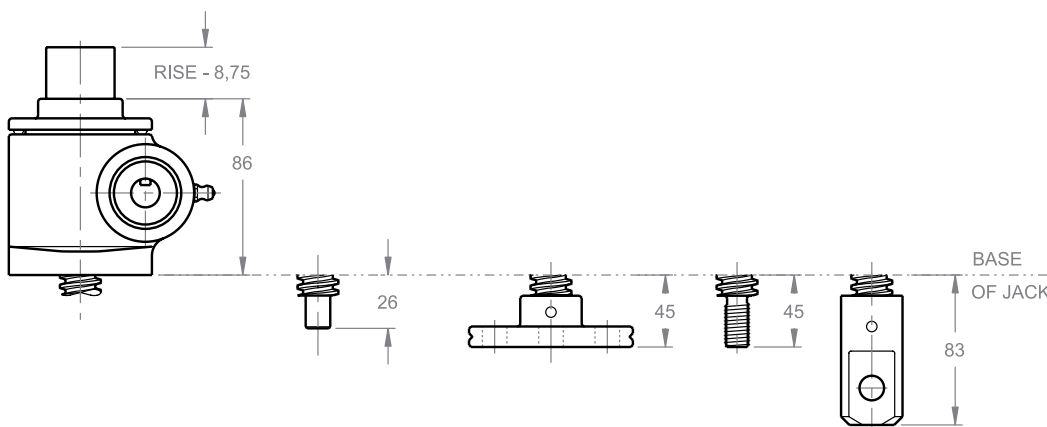

Inverted keyed

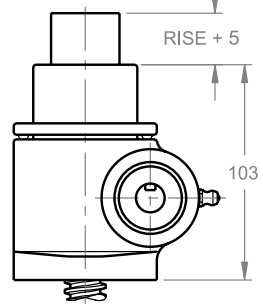

Note: Drawings are artist's conception — not for certification; dimensions are subject to change without notice.

# METRIC SCREW JACKS

25kN - 30mm SCREW

MWJ 62.5  
MWJ 122.5  
MWJ 242.5

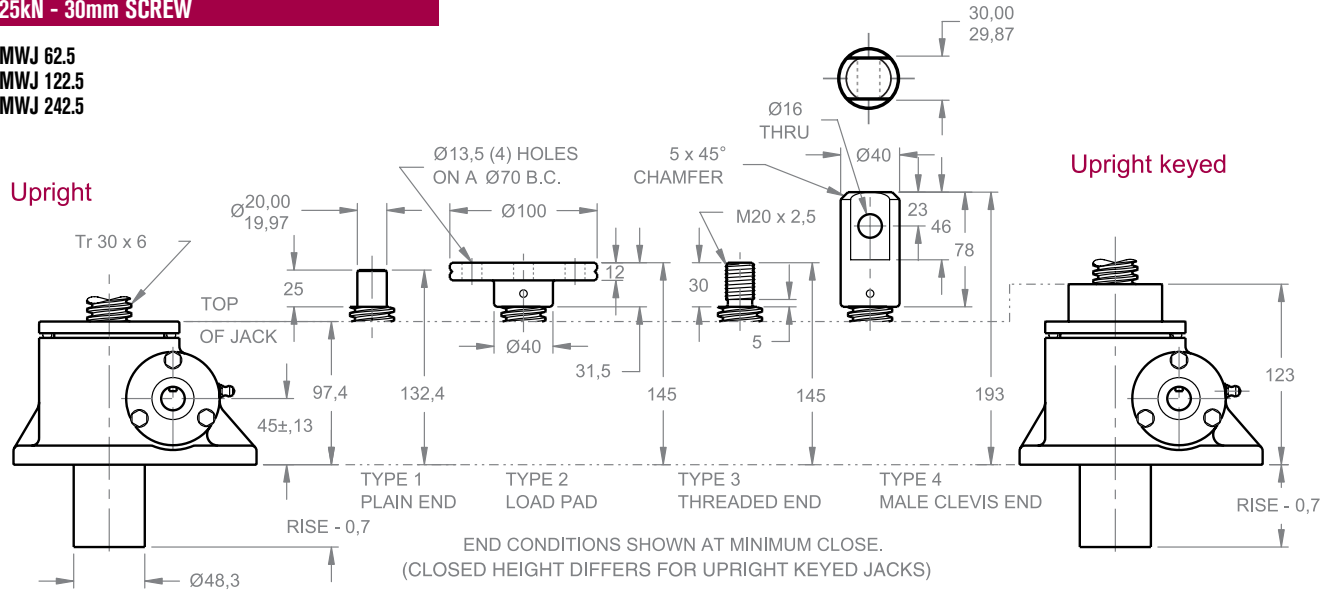

**Upright traveling nut**

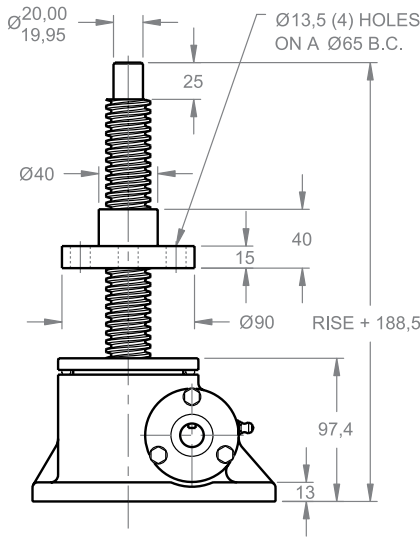

**Typical Plan View**

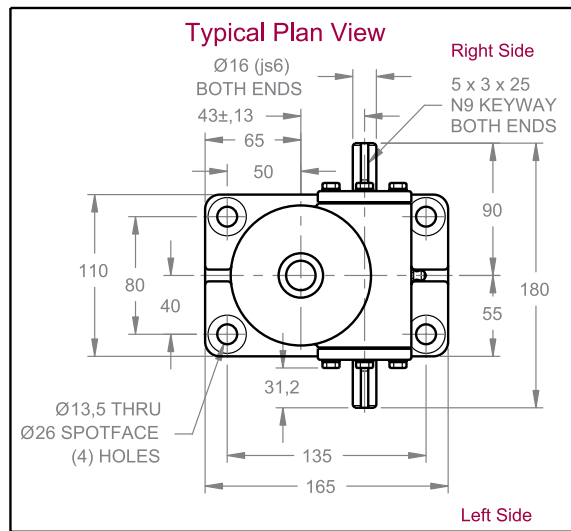

**Inverted traveling nut**

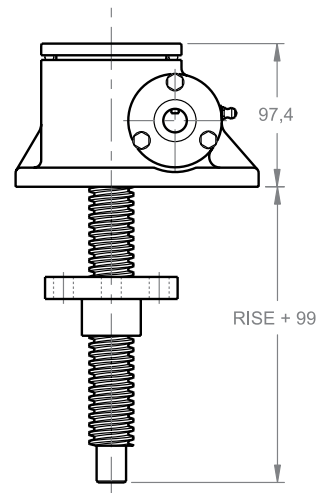

**Inverted**

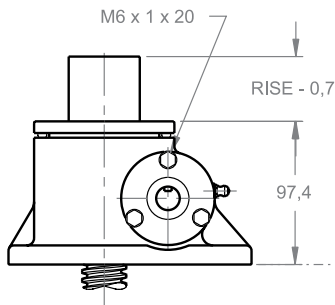

**Inverted keyed**

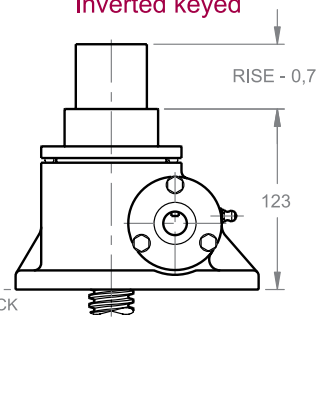

Note: Drawings are artist's conception — not for certification; dimensions are subject to change without notice.

# METRIC SCREW JACKS

## 50kN - 40mm SCREW

MWJ 65  
MWJ 125  
MWJ 245

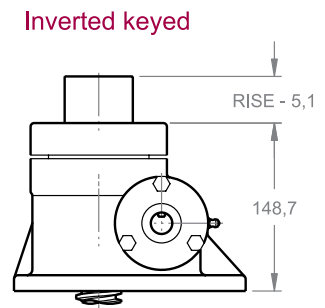
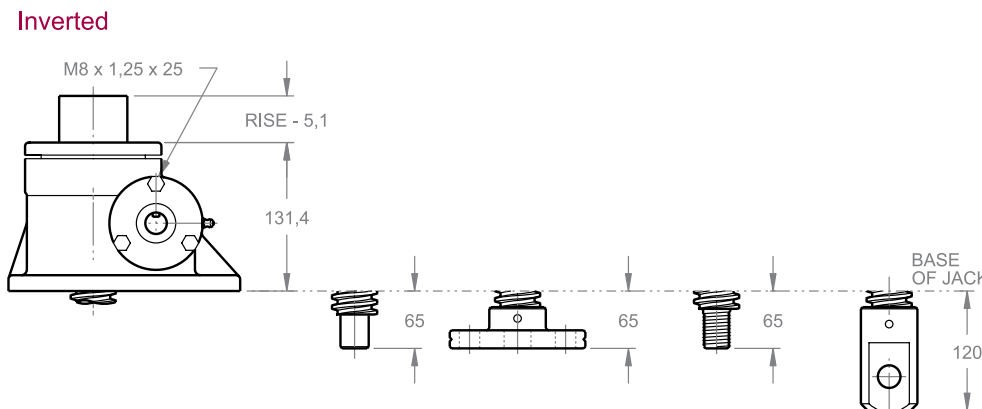
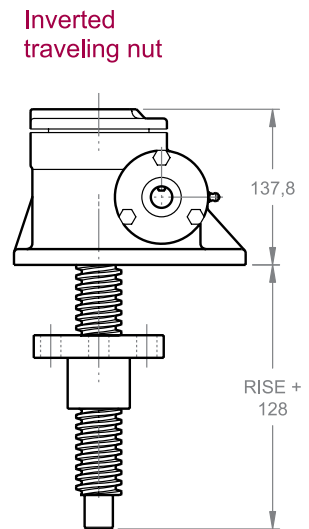
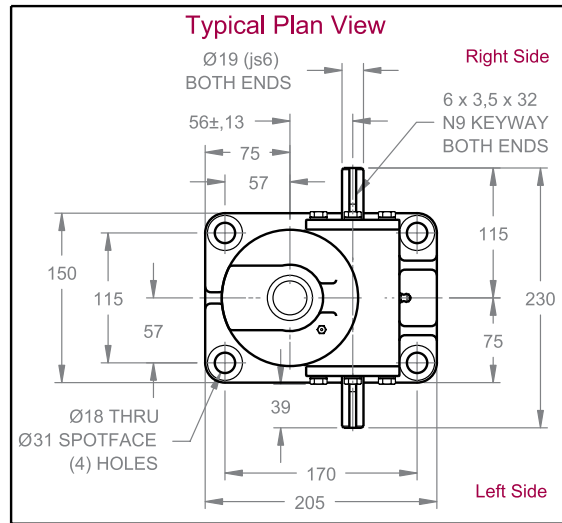
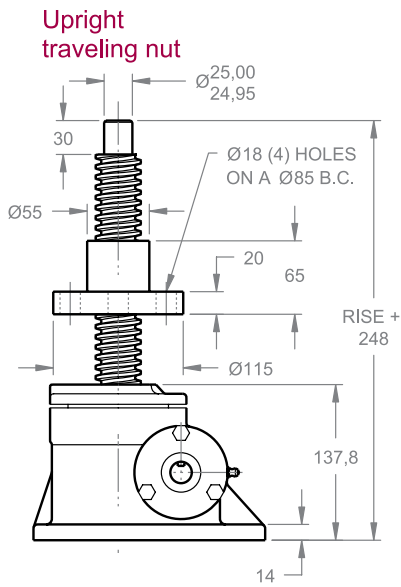
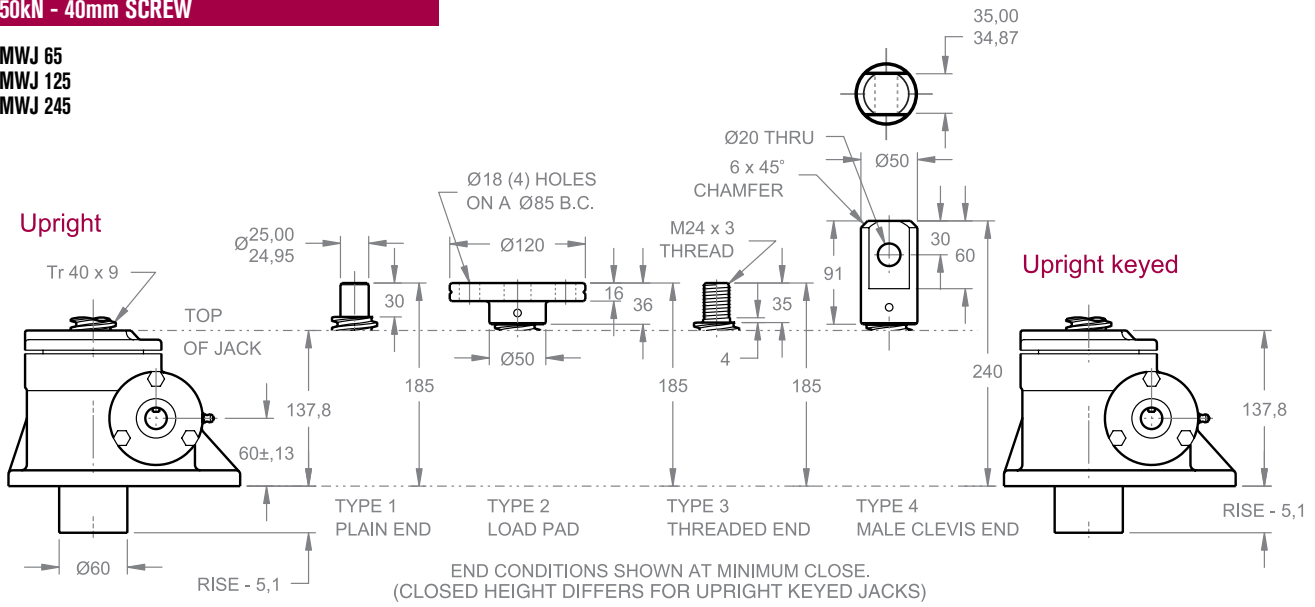

Note: Drawings are artist's conception — not for certification; dimensions are subject to change without notice.

# METRIC SCREW JACKS

100kN - 55mm SCREW

MWJ 810  
MWJ 2410

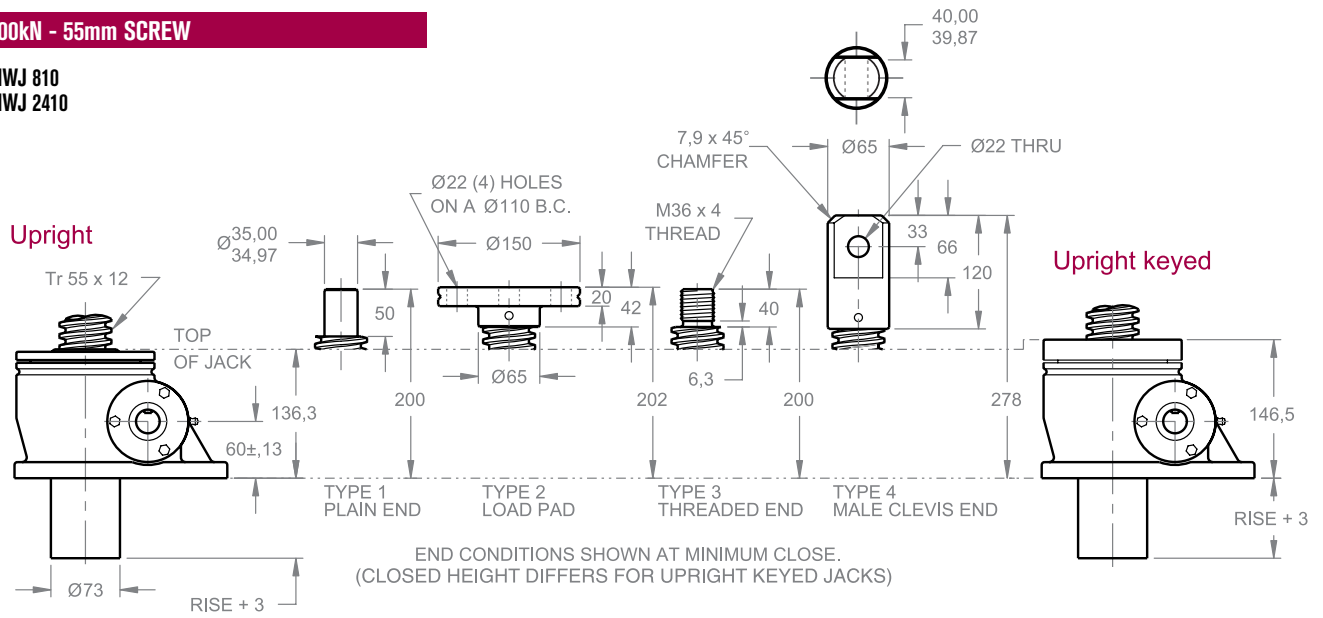

**Upright traveling nut**

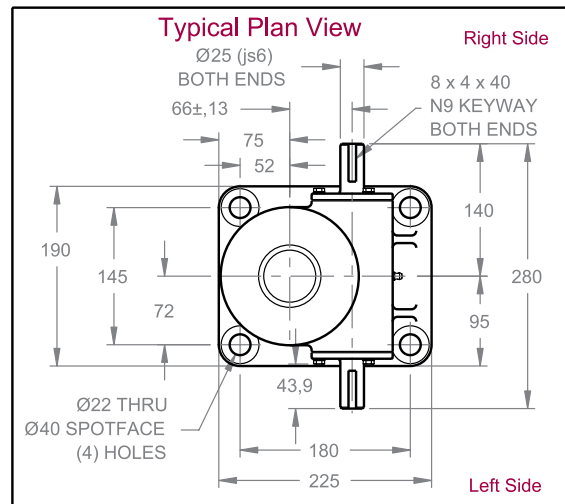
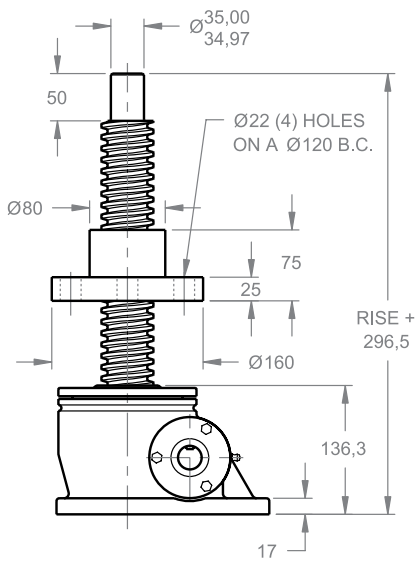

**Inverted traveling nut**

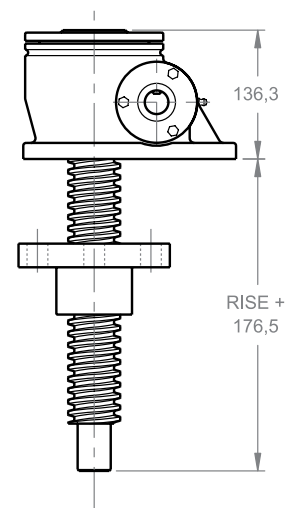

**Inverted**

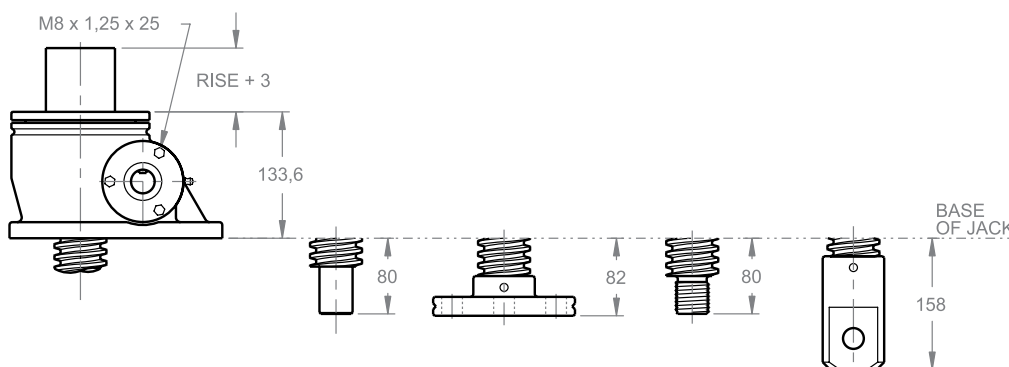

**Inverted keyed**

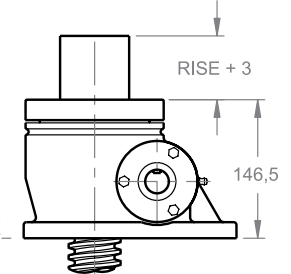

Note: Drawings are artist's conception — not for certification; dimensions are subject to change without notice.



Joyce ball screw jacks feature a ball nut with integral ball bearings that circulate along the surface of the ball screw. This significantly reduces friction between the ball nut and the ball screw, resulting in greater efficiency. Ball screw jacks require up to two-thirds less input torque to move the load than similarly rated machine screw jacks. They require a brake motor or external locking device to hold position.

Both upright and inverted ball screw jacks are available to lift and precisely position loads up to 50 tons. Alloy steel input shafts, aluminum bronze wormgears and tapered roller or ball thrust bearings provide rugged reliability. Select from standard lead (WB, WBL) and high lead (HWB, HWBL) models to meet your travel speed and ball nut life requirements.

Compared to machine screw jacks, Joyce ball screw jacks:

- Require less motor horsepower.
- Allow higher travel speed.
- Provide an extended duty cycle.

Joyce ball screw jacks are available with one of four standard screw ends or special ends to meet your requirements. Double input shafts are standard. Many options are available including oversized ball bearings, which can be specified to reduce endplay between ball screw and ball nut. All jack designs can be fitted with protective boots.

Joyce can customize ball screw jacks to meet your specifications.



# BALL SCREW JACKS

Joyce offers Ball Screw Jacks in several designs including:

- Translating
- Keyed for traveling nut (KFTN)
- Double clevis
- Trunnion mount

A guide for ordering is on pages 82 and 83.



# BALL SCREW JACKS ORDERING INFORMATION

Instructions: Select a model number from this chart.

1-Ton Standard	2-Ton Standard	2-Ton Reverse Base Standard	5-Ton Standard	10-Ton Standard	10-Ton Heavy Duty	20-Ton Standard	30-Ton Standard	50-Ton Standard
WBL51 WBL201	WB62 WB122 WB242	RWB62 RWB122 RWB242	WB65 WB125 WB245	WBL810 WBL2410	WB810 WB2410	WB820 WB2420	WB1130 WB3230	WB1150 WB3250
1-Ton Heavy Duty	2-Ton High Lead	2-Ton Reverse Base High Lead	5-Ton High Lead	10-Ton Standard High Lead	10-Ton Heavy Duty High Lead			50-Ton Reverse Base
WB51 WB201	HWB62 HWB122 HWB242	RHWB62 RHWB122 RHWB242	HWB65 HWB125 HWB245	HWBL810 HWBL2410	HWB810 HWB2410			RWB1150 RWB3250

**Important Note:** \*Not self-locking, may lower under load. Brake motors or external locking systems are required.  
\*\* Keyed for non-rotation is not a standard option. Contact sales@joycedayton.com

H: indicates High lead (2-ton, 5-ton and 10-ton only).

R: Reverse Base Jack (2-ton and 50-ton only).

## Sample Part Number: WB65U4S-6.0-STDX-STDX-B

### Jack Configuration



U=Upright I=Inverted

### End Conditions



1=T1 (plain end)  
2=T2 (load pad)  
3=T3 (threaded end)  
4=T4 (male clevis)

### Left Side Shaft Code

(see below)



XXXX=Remove  
STDX=Standard  
CUST=Custom  
For optional shaft codes, see page 83.

### Right Side Shaft Code

(see below)



XXXX=Remove  
STDX=Standard  
CUST=Custom  
For optional shaft codes, see page 83.

### Additional Options\*

X=Standard Jack, no additional options  
S=Additional Specification Required (comment as necessary)  
**Protective Boots pp. 171-173**  
B=Protective Boot  
D=Dual Protective Boot  
**Finishes p. 182**  
F1=Do Not Paint  
F2=Epoxy Paint  
F3=Outdoor Paint Process  
**Motor Options**  
M1=Less Motor  
M2=Brake Motor  
M3=Single Phase Motor (120VAC)  
M4=50Hz Motor  
M5=Special Motor  
**Grease/Seals**  
H1=High Temperature Operation  
H2=Food Grade  
**Screw Stops**  
ST0=Extending  
\* Specify as many options as needed

### Ball Screw Jack Rise

Rise is travel expressed in inches and not the actual screw length.

### Jack Designs



S=Translating K=Keyed for Non Rotation\*\* N=Traveling Nut D=Double Clevis A=KFTN Trunnion\* T=Trunnion\*

\*Standard trunnion mounts available on 2-ton through 20-ton jacks. (See page 183)

\*\*Keyed for non-rotation is not a standard option. Contact Joyce with your requirements.

# BALL SCREW JACKS SHAFT CODES

**Instructions:** Select the appropriate shaft codes for both right and left hand shafts. One shaft code must be specified for each side of the jack.

## Screw Stops (p. 10) and Boots (pp. 171-173)

Extending Screw stops are optional on ball screw jacks. When specified the closed height of the jack and the protection tube length may be increased.

When boots are added to ball screw jacks, the closed height of the jack may be increased.

## G geared Potentiometers (p. 175)

POTA=0-10V

POTB=4-20mA

POTC=0-10V w/2 switches

POTD=4-20mA w/2 switches

IP65 rated enclosures



## Encoders (pp. 176-177)

ENCA=Absolute Encoder 0-10 VDC, programmable

ENCB=Absolute Encoder 4-20mA, programmable

ENCC=Absolute Encoder CAN Open

ENCD=Absolute Encoder SSI

ENCS=Stainless Steel Incremental Encoder 1024 PPR

ENCX=Incremental Encoder 200 PPR

ENCY=Incremental Encoder 1024 PPR



## Motors for Systems and Direct Drive (pp. 178-179)

- All standard motors are 3-phase, 208-230/460 VAC or 230/460 VAC. Other motor options are available. Specify the appropriate motor size from the chart on the right.
- Refer to the "Additional Options" chart on the preceding page as needed.
- Brake motors (M2) are required for ball screw jacks.
- If the motor frequency will be varied to provide a "soft" start, an inverter duty brake motor may be required.

## Motors

Size	Code
1/4 HP	K
1/3 HP	A
1/2 HP	B
3/4 HP	C
1 HP	D
1-1/2 HP	E
2 HP	F
3 HP	L
5 HP	G
7-1/2 HP	H
10 HP	I
15 HP	J

## Motor Mounts (pp. 178-179)

Ordering Example:

**MMA A**

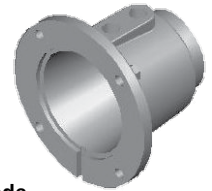

MMA=56C

MMB=140TC

MMC=180TC

MMD=210TC

Motor code from chart at left  
For servo motor mounts see p. 178

Standard motor adapters are aluminum.

## Mechanical Limit Switches (p. 174)

Ordering Example: **LA13**

Models		Number of DPDT Switches (see p. 174)	Available Positions							
Model	Code		1	2*	3	4	5	6*	7	8
LS7-402	LI	NOTE: Will always be 0 for LS7 models								
LS8-402	LA									
LS8-404	LB									

• 2, 5, 10, 15, and 20 Ton ball screw jacks are available with positions #1, #3, and #5.  
 • 30-ton and 50-ton ball screw jacks are available with positions #1, #4, #7 and #8.  
 \*These positions are not standard. Contact Joyce with your requirements.

# BALL SCREW JACKS COLUMN LOADING

Ball Screw Jacks Column Loading Chart



This chart includes a 2:1 Factor-of-Safety based on the Euler-Johnson equation for column loading (Oberg, Erik et al. Machinery's Handbook, 24th Edition. c. 1992 Industrial Press Inc.) The horizontal portion of each line represents the jack's maximum dynamic capacity. Under static conditions, these lines can be exceeded. Please contact factory for assistance.

# BALL SCREW JACKS SPECIFICATIONS

Model	Capacity	Screw Diameter (Inches)	Thread Pitch/Lead	Worm Gear Ratio	Worm Shaft Turns for 1" Travel	Tare Torque (Inch Lbs.)	Starting Torque (Inch Lbs.)	Operating Torque (Inch Lbs.)	Efficiency Rating % Approx	Screw Torque (Inch Lbs.)	Worm Holding Torque	Ball Nut Life at Rated Load (Inch Screw Travel x 1000)	Basic Jack Weight (Lbs.)	Screw Weight per Inch Travel (Lbs.)	
WBL51	1 ton	3/4	0.2	5:1	25	3	.014W*	.012W* @ 500 RPM	51.7	.035W*	.006W*	108	8	0.25	
WBL201				20:1	100		.005W*	.004W* @ 500 RPM	38.5		.002W*				
WB51				5:1	25		.014W*	.012W* @ 500 RPM	51.7		.006W*	858			
WB201				20:1	100		.005W*	.004W* @ 500 RPM	38.5		.002W*				
(R)WB62	2 ton	1	0.25	6:1	24	4	.015W*	.013W* @ 500 RPM	52.1	.044W*	.007W*	642	18	0.4	
(R)WB122				12:1	48		.009W*	.007W* @ 500 RPM	47.2		.004W*				
(R)WB242				24:1	96		.006W*	.004W* @ 500 RPM	39.3		.002W*				
(R)HWB62			1.0	6:1	6		.064W*	.051W* @ 500 RPM	52.1	.033W*	.177W*	.020W*			190
(R)HWB122				12:1	12		.039W*	.028W* @ 500 RPM	47.2	.014W*					
(R)HWB242				24:1	24		.028W*	.017W* @ 500 RPM	39.3	.014W*					
WB65	5 ton	1 1/2	0.474	6:1	12.66	10	.030W*	.025W* @ 300 RPM	51.1	.084W*	.013W*	1015	42	0.7	
WB125				12:1	25.33		.019W*	.014W* @ 300 RPM	45.7		.007W*				
WB245				24:1	50.66		.013W*	.008W* @ 300 RPM	37.2		.004W*				
HWB65			1.0	6:1	6		.065W*	.052W* @ 300 RPM	51.1	.033W*	.177W*	.020W*			512
HWB125				12:1	12		.041W*	.029W* @ 300 RPM	45.7	.014W*					
HWB245				24:1	24		.029W*	.018W* @ 300 RPM	37.2	.014W*					
WBL810	10 ton	1 1/2	0.474	8:1	16.88	20	.022W*	.019W* @ 200 RPM	50.7	.084W*	.010W*	127	58	0.9	
WBL2410				24:1	50.66		.010W*	.008W* @ 200 RPM	40.3		.004W*				
HWBL810			1.0	8:1	8		.047W*	.039W* @ 200 RPM	50.7	.024W*	.177W*	.012W*			64
HWBL2410				24:1	24		.024W*	.016W* @ 200 RPM	40.3	.012W*					
WB810	10 ton	2	0.5	8:1	16	20	.023W*	.019W* @ 200 RPM	50.7	.088W*	.009W*	729	62	1.4	
WB2410				24:1	48		.011W*	.008W* @ 200 RPM	40.3		.003W*				
HWB810			1.0	8:1	8		.047W*	.039W* @ 200 RPM	50.7	.018W*	.177W*	.006W*			1423
HWB2410				24:1	24		.023W*	.016W* @ 200 RPM	40.3	.006W*					
WB820	20 ton	2 1/4	0.5	8:1	16	40	.024W*	.020W* @ 200 RPM	47.4	.088W*	.009W*	121	105	2.6	
WB2420				24:1	48		.012W*	.009W* @ 200 RPM	35		.003W*				
WB1130	30 ton	3	0.66	11:1	16.67	60	.027W*	.020W* @ 200 RPM	48	.117W*	.009W*	343	220	3.2	
WB3230				32:1	48.48		.016W*	.009W* @ 200 RPM	35		.003W*				
(R)WB1150	50 ton	4	1.0	11:1	11	100	.038W*	.029W* @ 200 RPM	49.3	.177W*	.013W*	614	460	4.8	
(R)WB3250				32:1	32		.020W*	.012W* @ 200 RPM	37.5		.005W*				

**Important Note:** Ball Screw Jacks are not self-locking. Brake motors or external locking systems are required.

**(R):** Reverse Base Jack.

**\*W:** Load in pounds.

**Tare Torque:** Initial torque to overcome seal and normal assembly drag. This value must be added to starting torque or operating torque values.

**Starting Torque:** Torque value required to start moving a given load (dissipates to operating torque values once the load begins moving).

**Operating Torque:** Torque required to continuously raise a given load at the input RPM listed.

**Screw Torque:** Torque required to resist screw rotation (Translating Design Jacks) and traveling nut rotation (Keyed for Traveling Nut Design Jacks).

**Worm Holding Torque:** Torque required to prevent input shaft (worm) from backdriving.

**Lead:** The distance traveled axially in one rotation of the lifting screw.

**Pitch:** The distance from a point on a screw thread to a corresponding point on the next thread, measured axially.

**Note:** This chart is provided for reference only. For specific information such as column loading, ball nut life and other performance factors please refer to JAX® Online software or contact Joyce.

# BALL SCREW JACKS

## 1 TON - 3/4" SCREW STANDARD DUTY

WBL 51 / WBL 201

### Upright

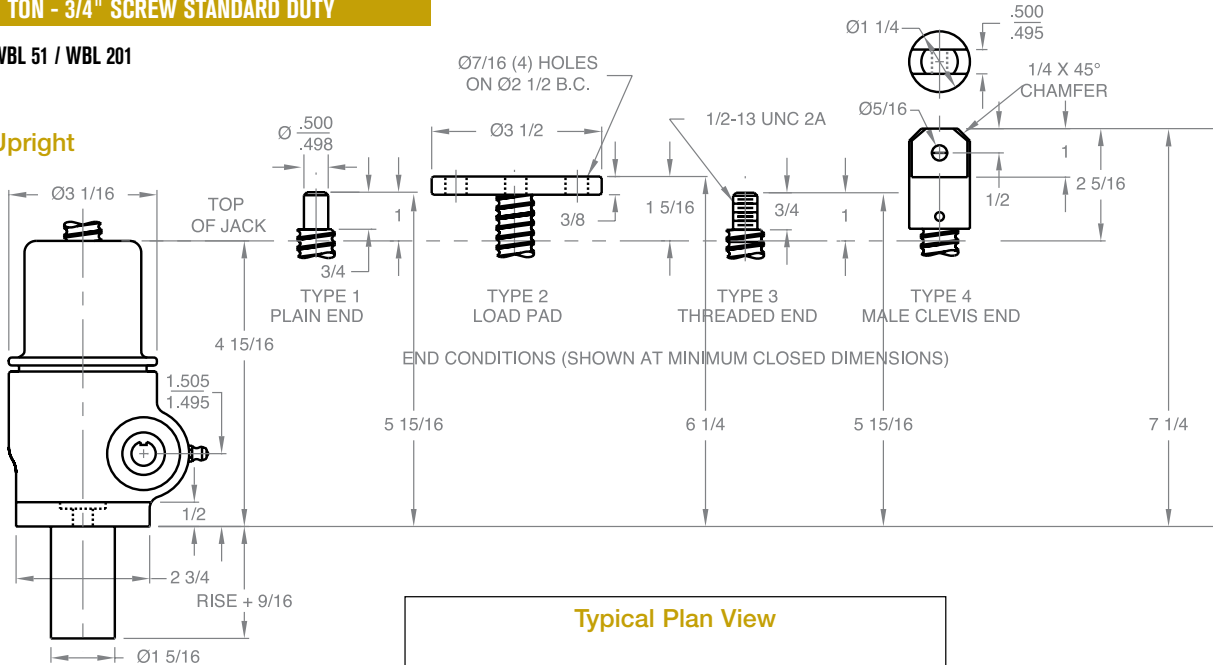

### Upright traveling nut

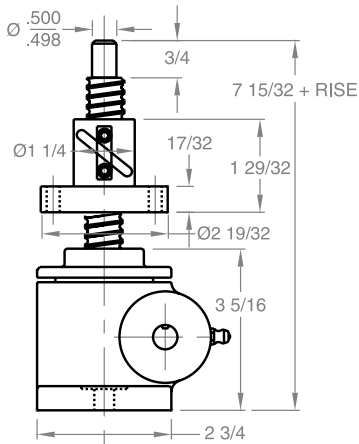

### Inverted

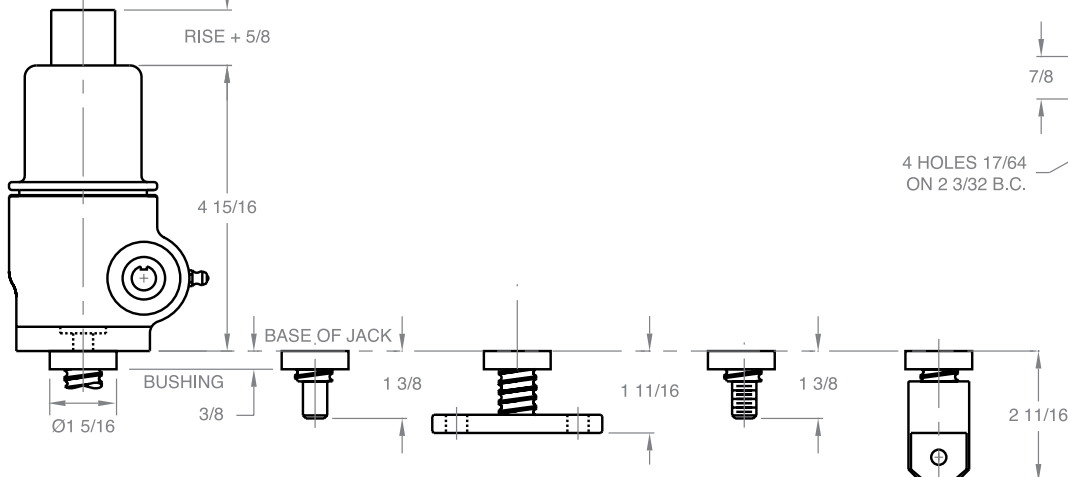

### Typical Plan View

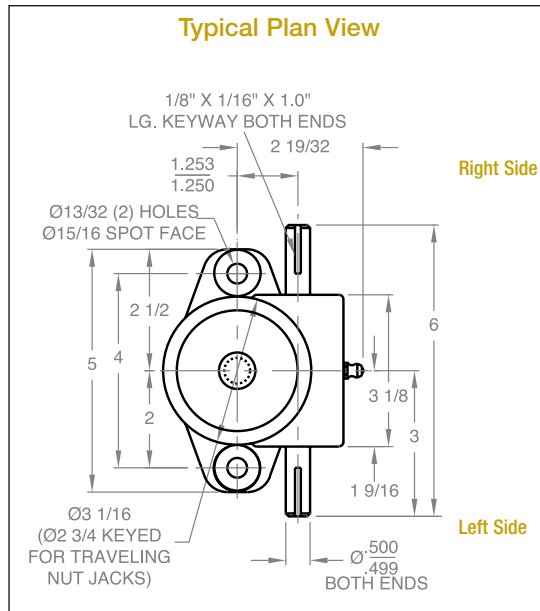

### Inverted traveling nut

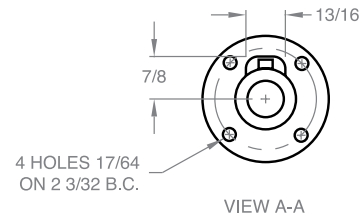
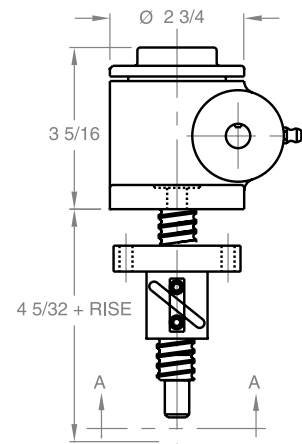

Note: Drawings are artist's conception — not for certification; dimensions are subject to change without notice.

# BALL SCREW JACKS

## 1 TON - 3/4" SCREW HEAVY DUTY

WB 51 / WB 201

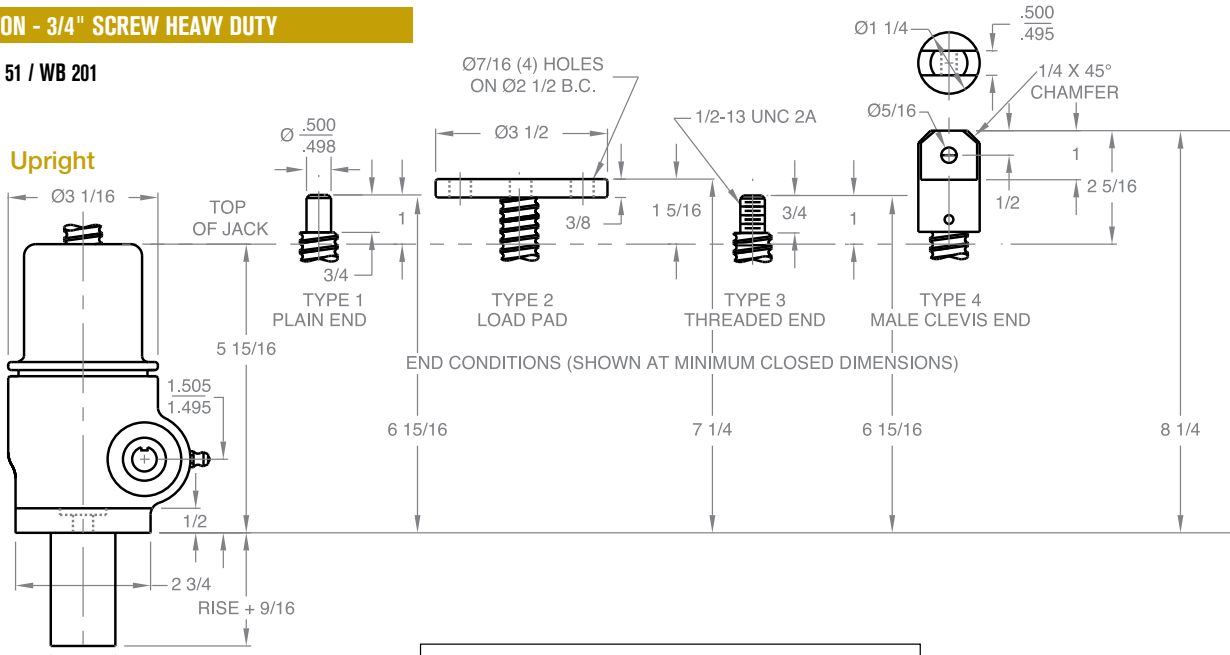

### Upright traveling nut

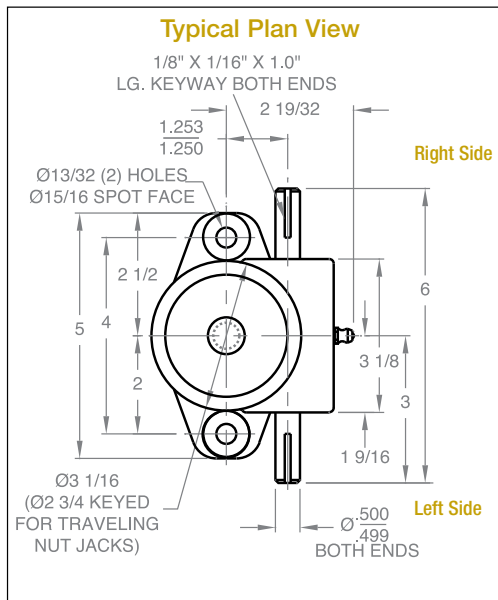
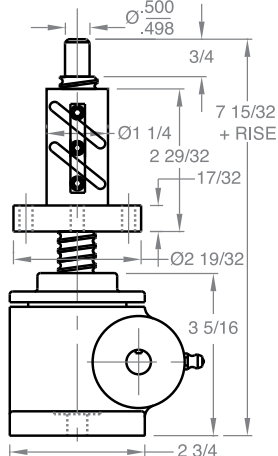

### Inverted traveling nut

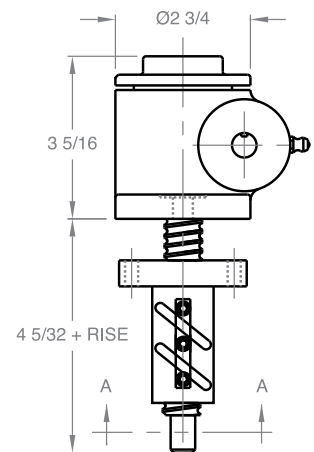

### Inverted

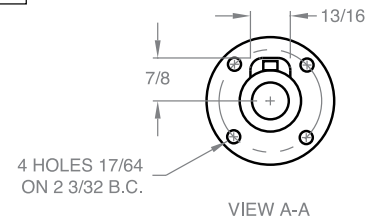
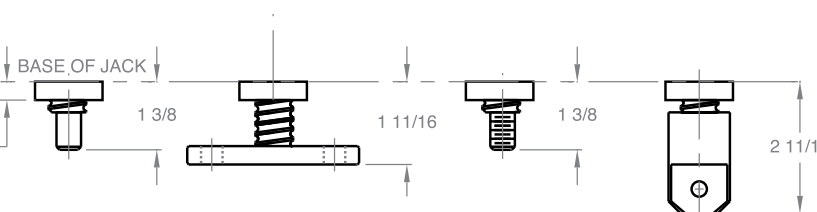
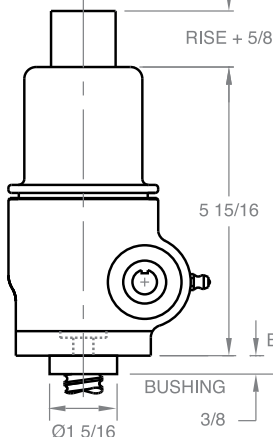

Note: Drawings are artist's conception — not for certification; dimensions are subject to change without notice.

# BALL SCREW JACKS

## 2 TON - 1" SCREW STANDARD

WB 62 / WB 122 / WB 242

### Upright

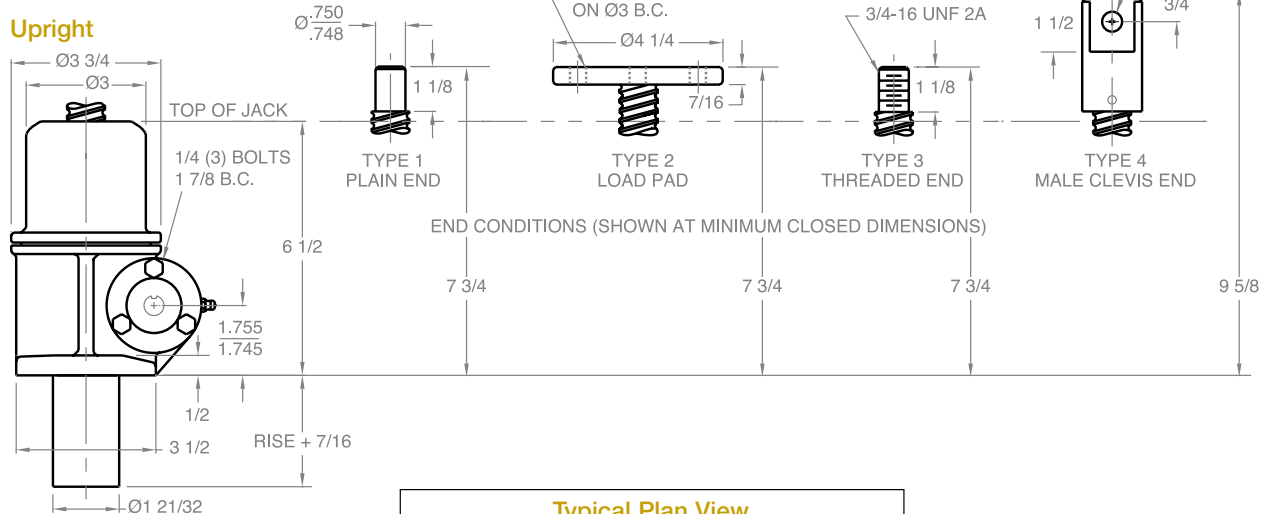

### Upright traveling nut

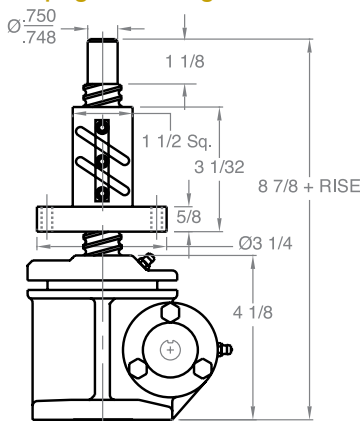

### Inverted

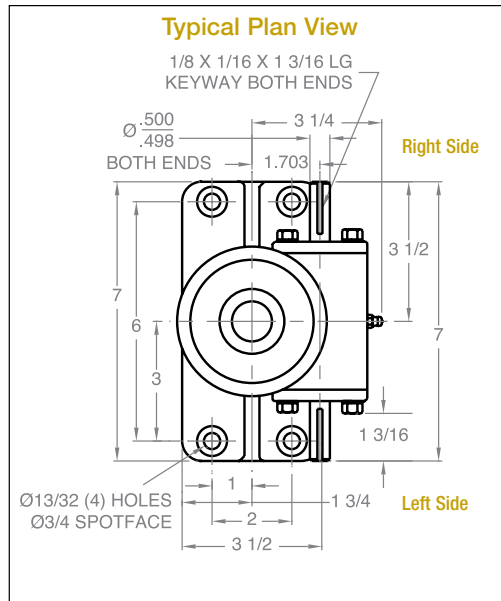
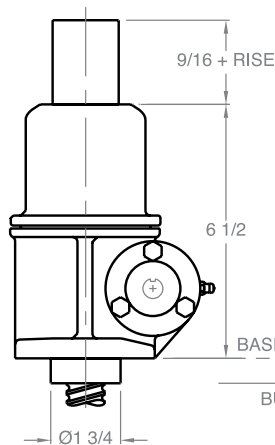

### Inverted traveling nut

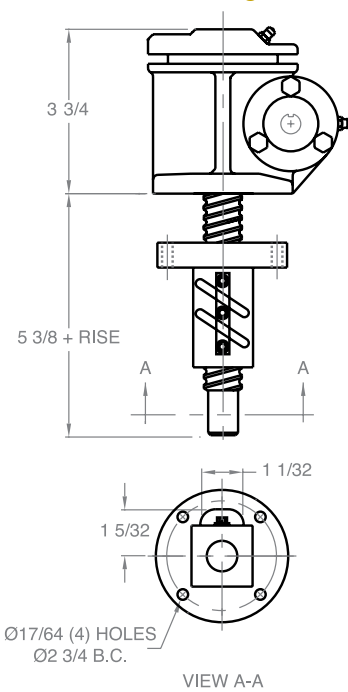

FOR DOUBLE CLEVIS DESIGN  
CONTACT JOYCE

Note: Drawings are artist's conception — not for certification; dimensions are subject to change without notice.



# BALL SCREW JACKS

## 2 TON REVERSE BASE - 1" SCREW STANDARD

RWB 62 / RWB 122 / RWB 242

### Upright

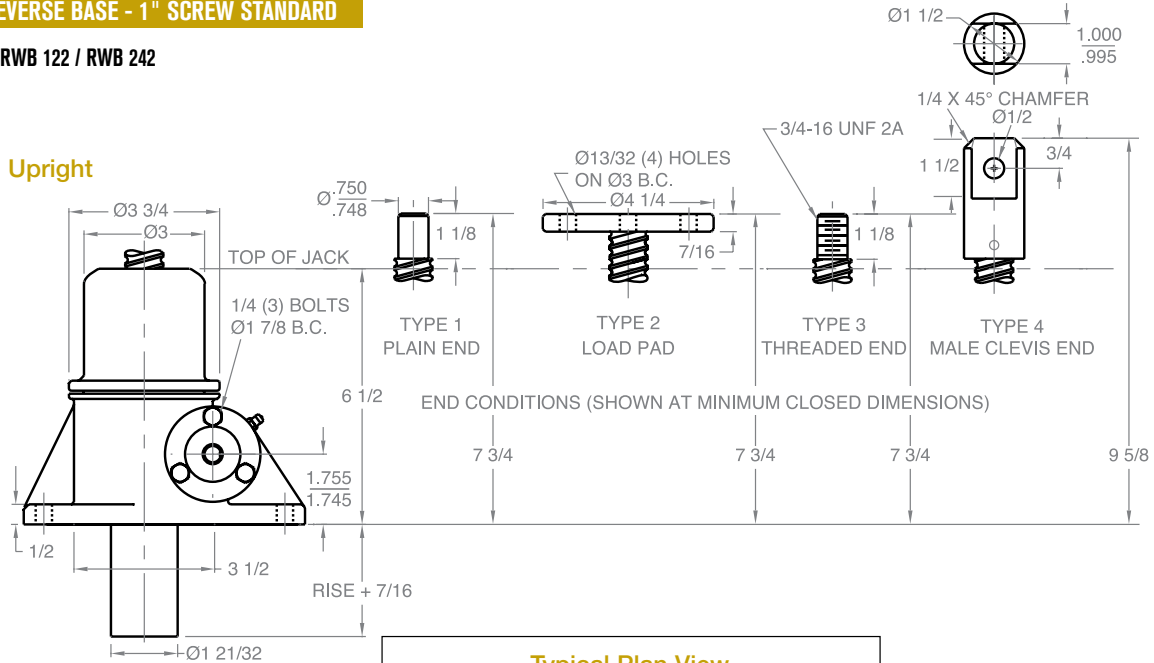

### Upright traveling nut

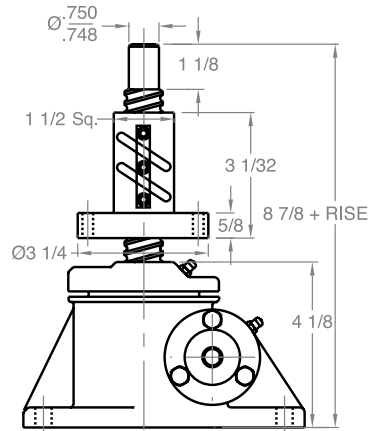

### Typical Plan View

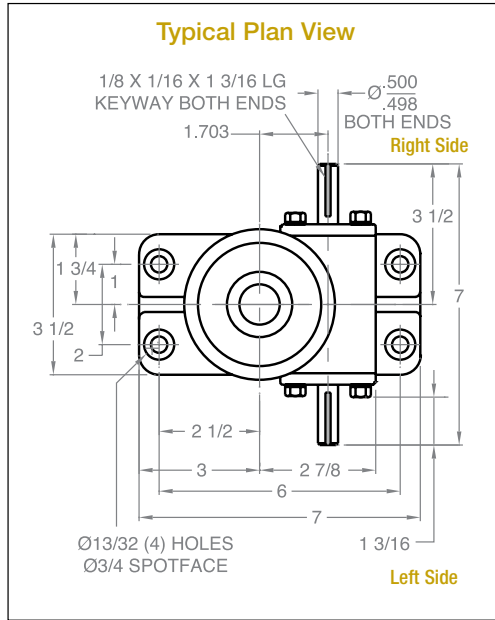

### Inverted traveling nut

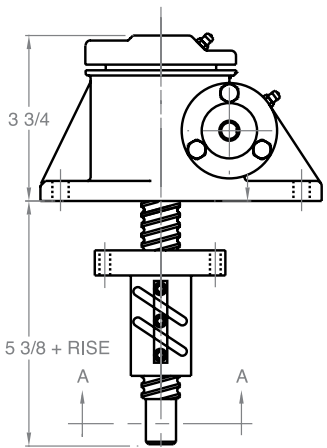

### Inverted

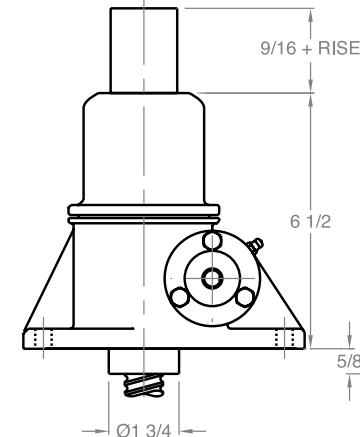

FOR DOUBLE CLEVIS DESIGN CONTACT JOYCE

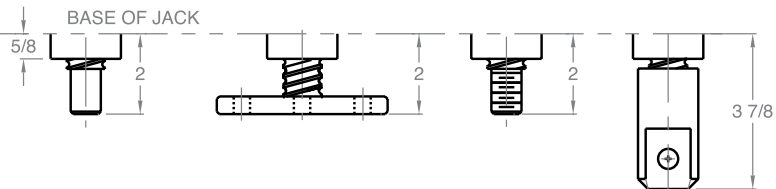
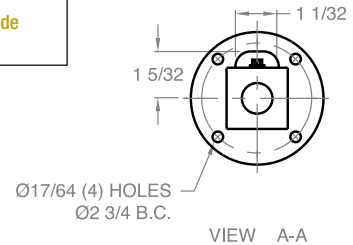

Note: Drawings are artist's conception — not for certification; dimensions are subject to change without notice.

# BALL SCREW JACKS

## 2 TON - 1" SCREW HIGH LEAD

HWB 62 / HWB 122 / HWB 242

### Upright

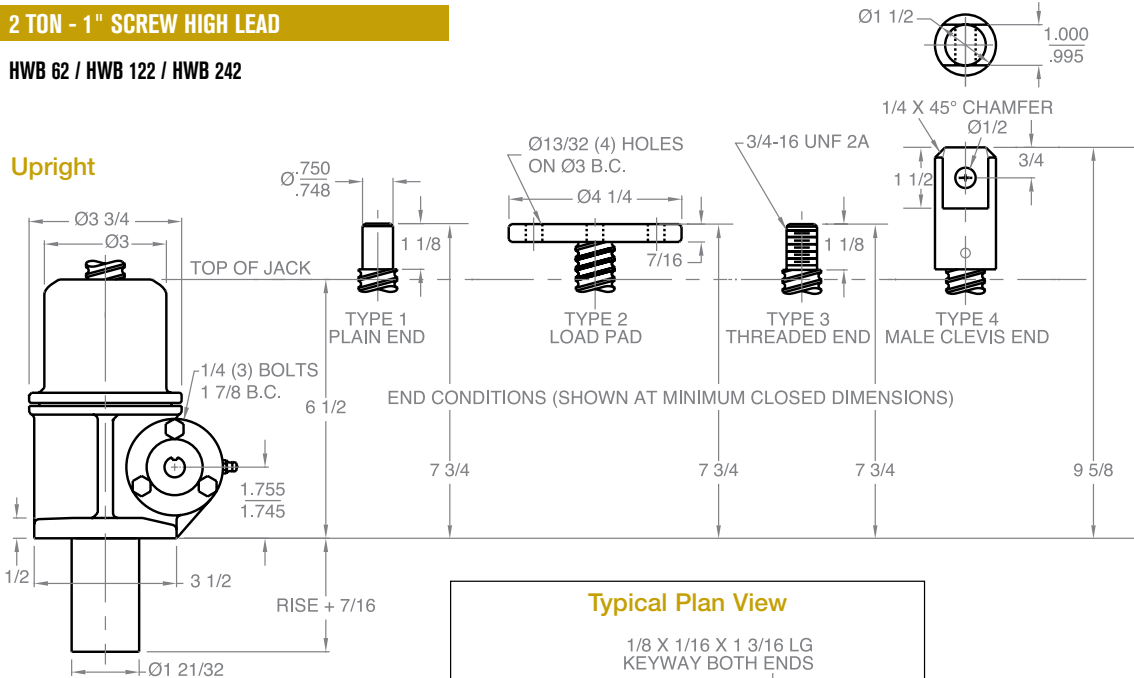

### Upright traveling nut

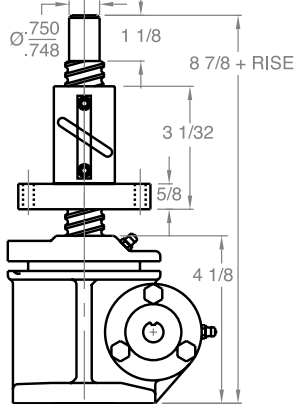

### Inverted

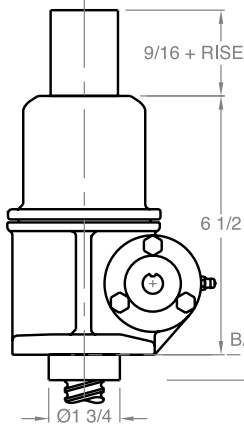

### Typical Plan View

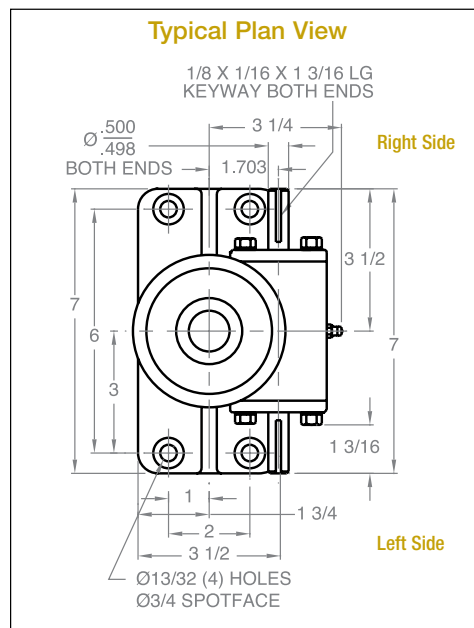

### Inverted traveling nut

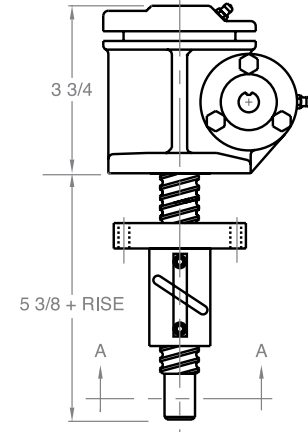

FOR DOUBLE CLEVIS DESIGN CONTACT JOYCE

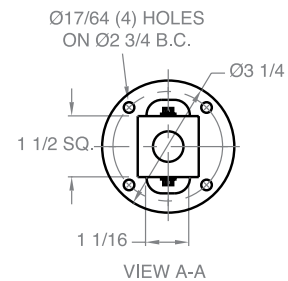

Note: Drawings are artist's conception — not for certification; dimensions are subject to change without notice.

# BALL SCREW JACKS

2 TON REVERSE BASE - 1" SCREW HIGH LEAD

RHWB 62 / RHWB 122 / RHWB 242

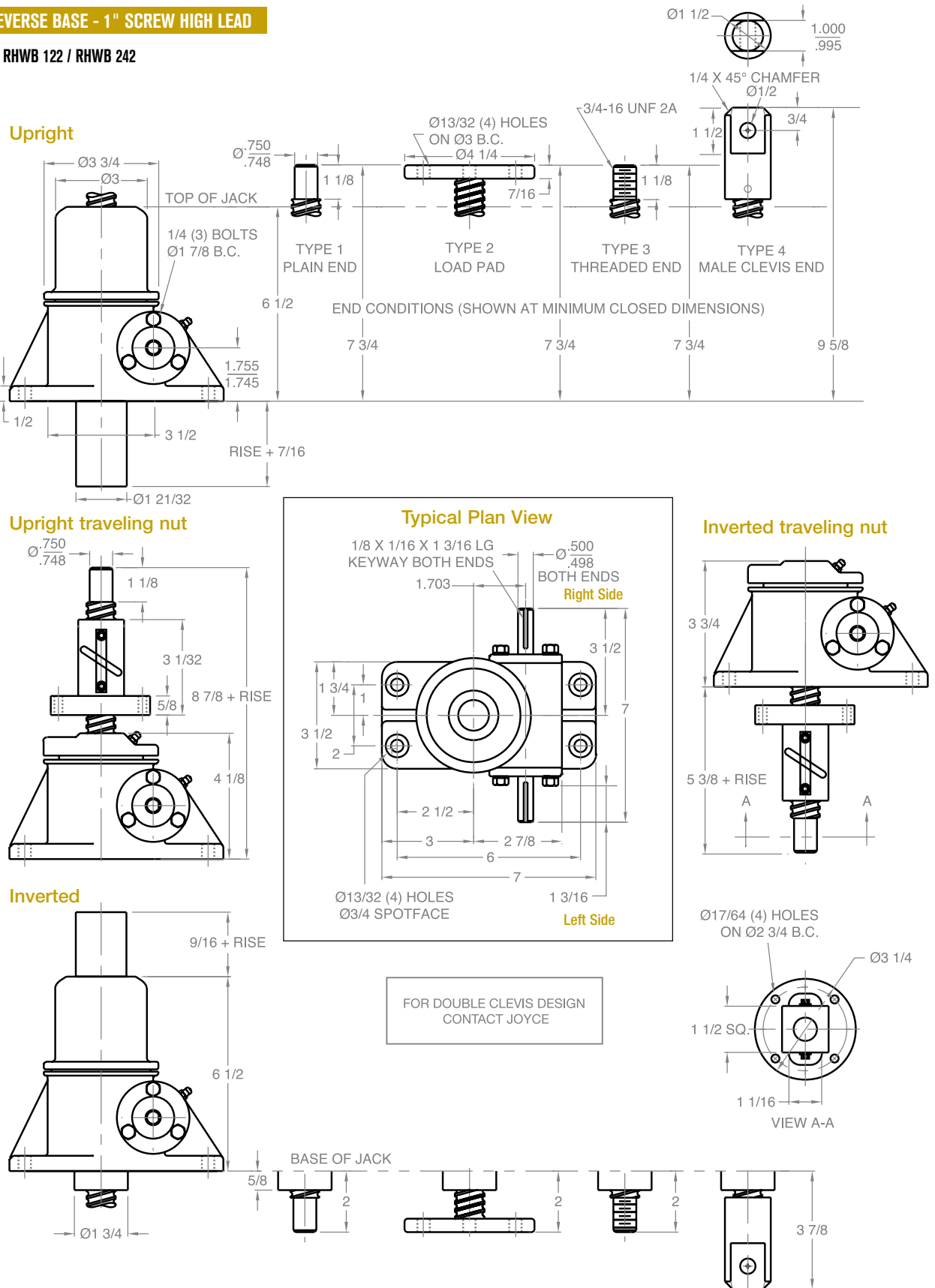

Note: Drawings are artist's conception — not for certification; dimensions are subject to change without notice.

# BALL SCREW JACKS

## 5 TON - 1 1/2" SCREW STANDARD

WB 65 / WB 125 / WB 245

### Upright

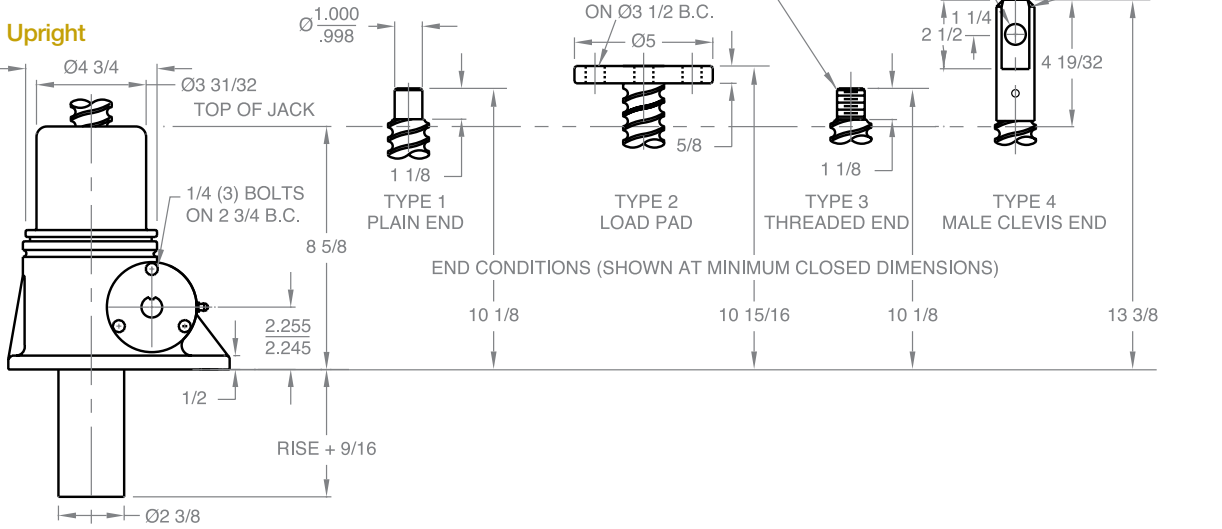

### Upright traveling nut

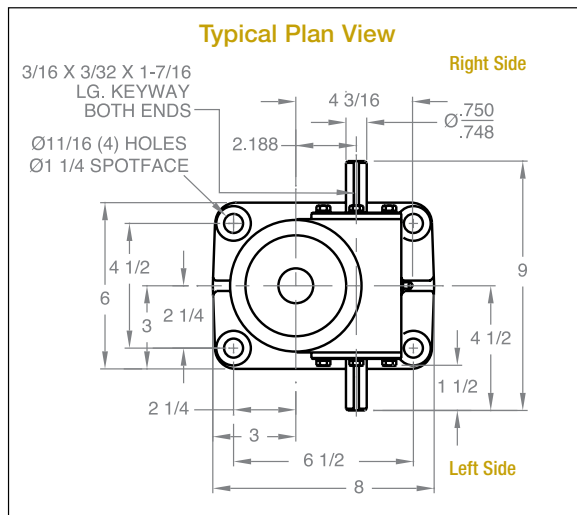
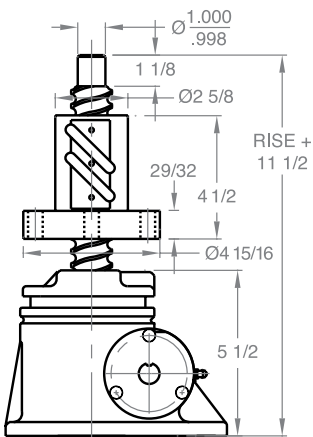

### Inverted traveling nut

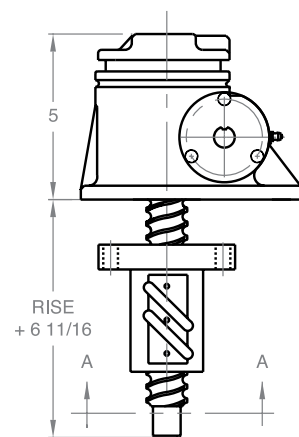

### Inverted

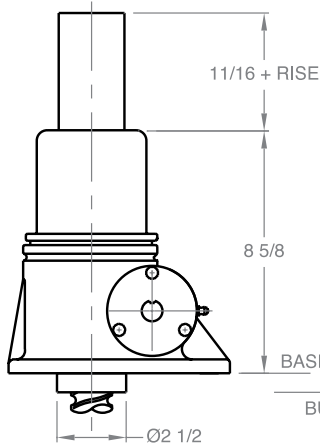

FOR DOUBLE CLEVIS DESIGN CONTACT JOYCE

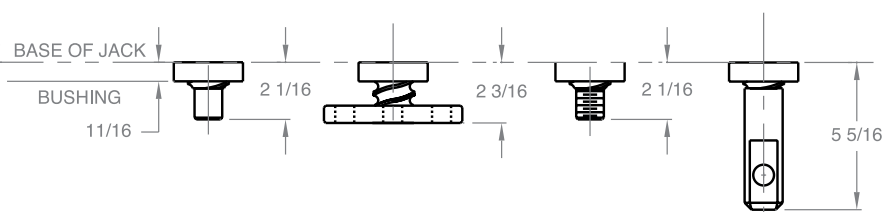
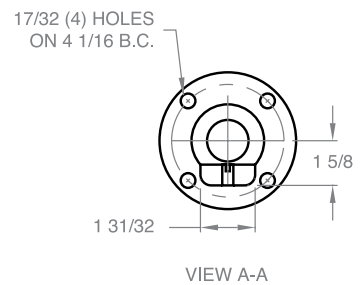

Note: Drawings are artist's conception — not for certification; dimensions are subject to change without notice.

# BALL SCREW JACKS

5 TON - 1 1/2" SCREW HIGH LEAD

HWB 65 / HWB 125 / HWB 245

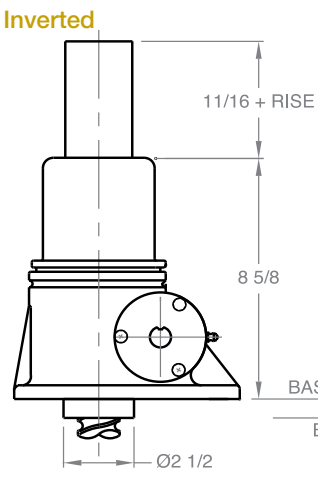
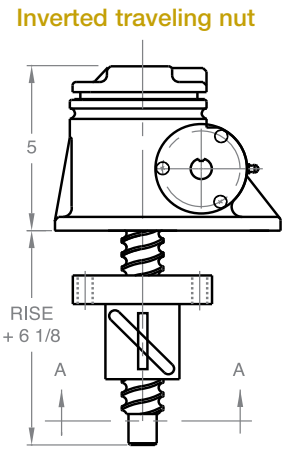
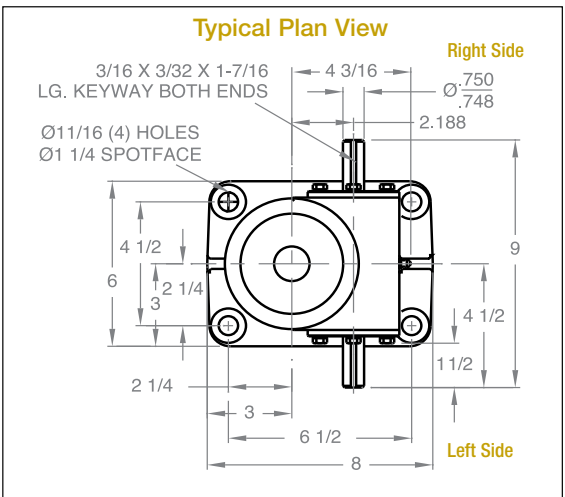
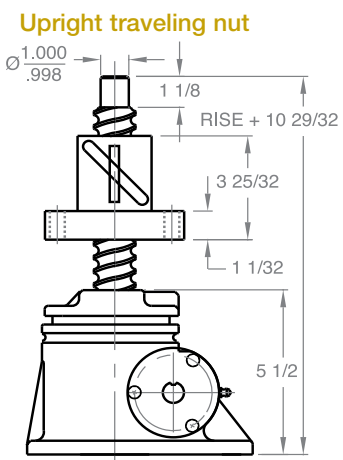
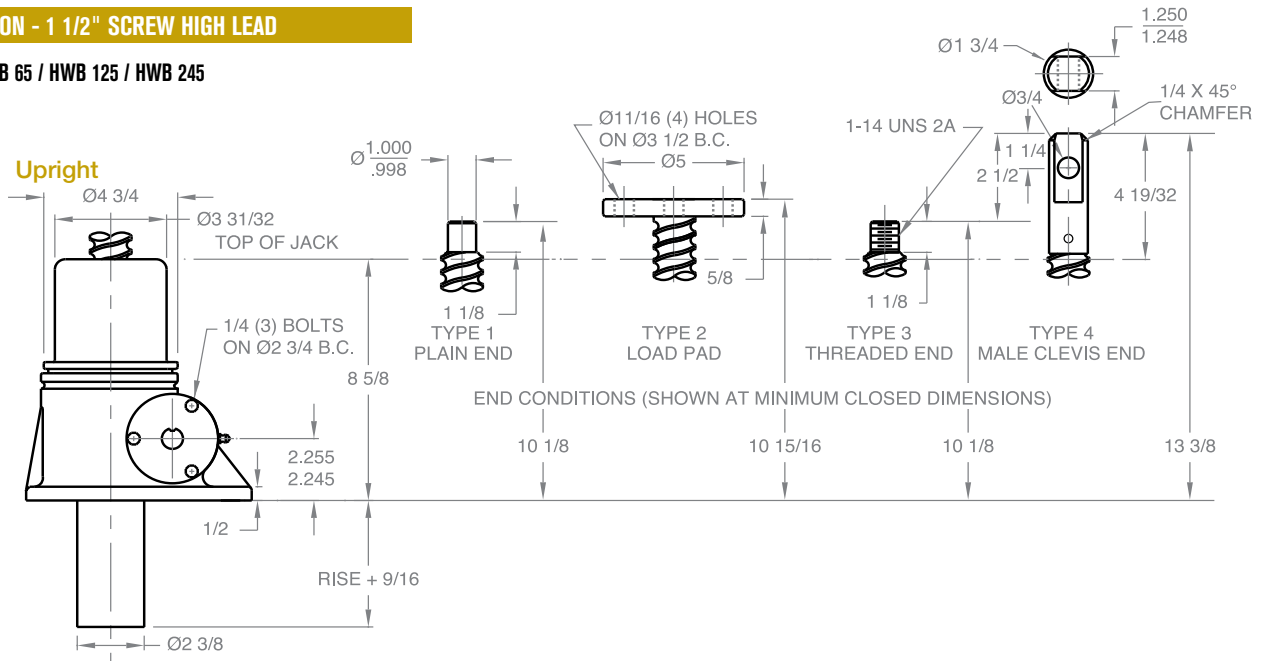

FOR DOUBLE CLEVIS DESIGN CONTACT JOYCE

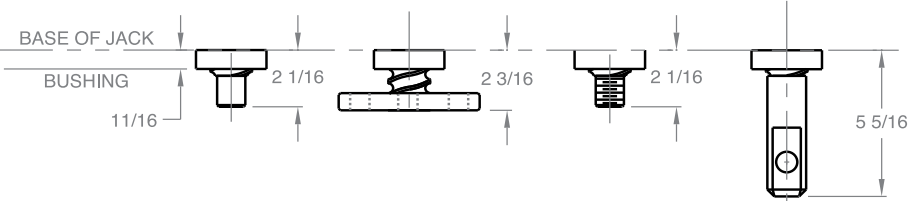
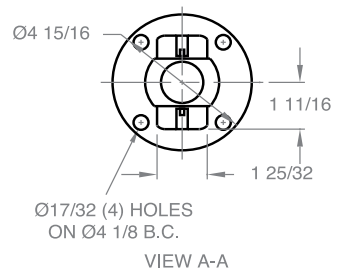

Note: Drawings are artist's conception — not for certification; dimensions are subject to change without notice.

# BALL SCREW JACKS

## 10 TON - 1 1/2" SCREW STANDARD

WBL 810 / WBL 2410

### Upright

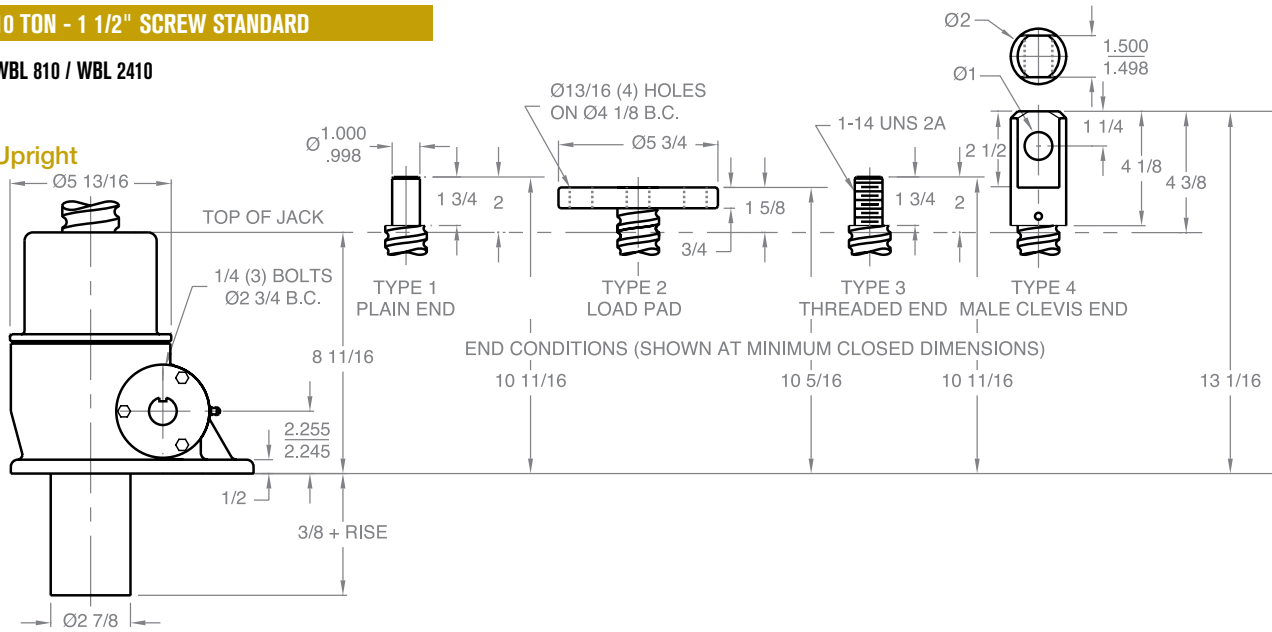

### Upright traveling nut

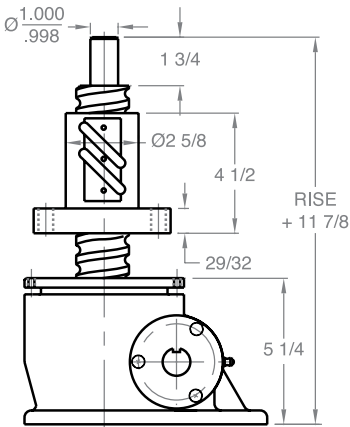

### Typical Plan View

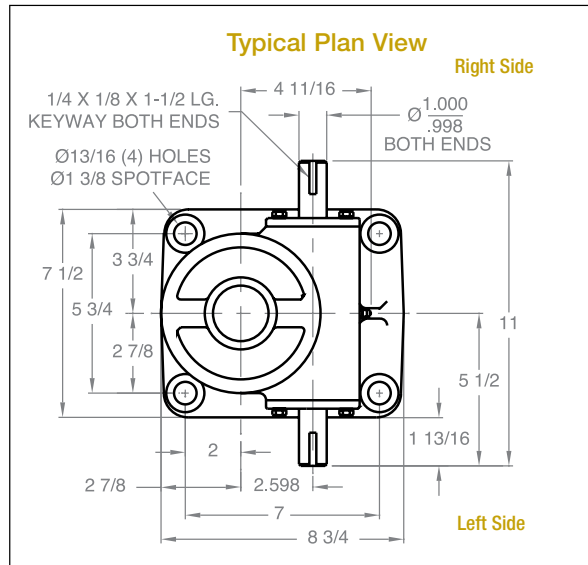

### Inverted traveling nut

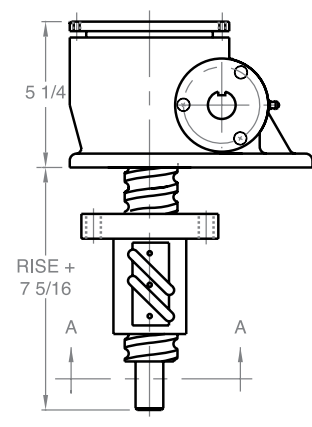

### Inverted

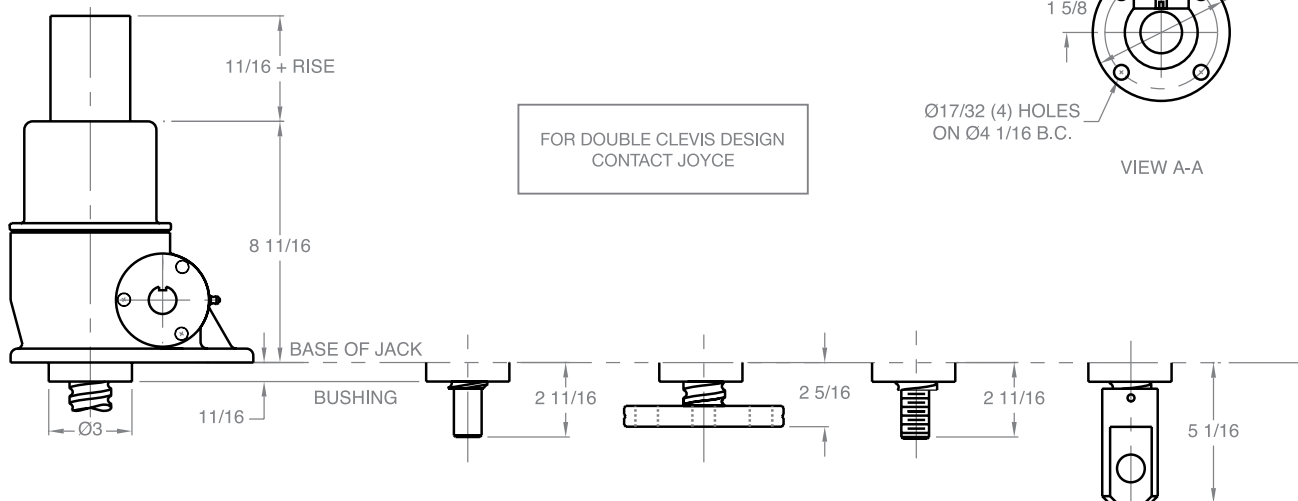

Note: Drawings are artist's conception — not for certification; dimensions are subject to change without notice.

# BALL SCREW JACKS

## 10 TON - 1 1/2" SCREW STANDARD HIGH LEAD

HWBL 810 / HWBL 2410

### Upright

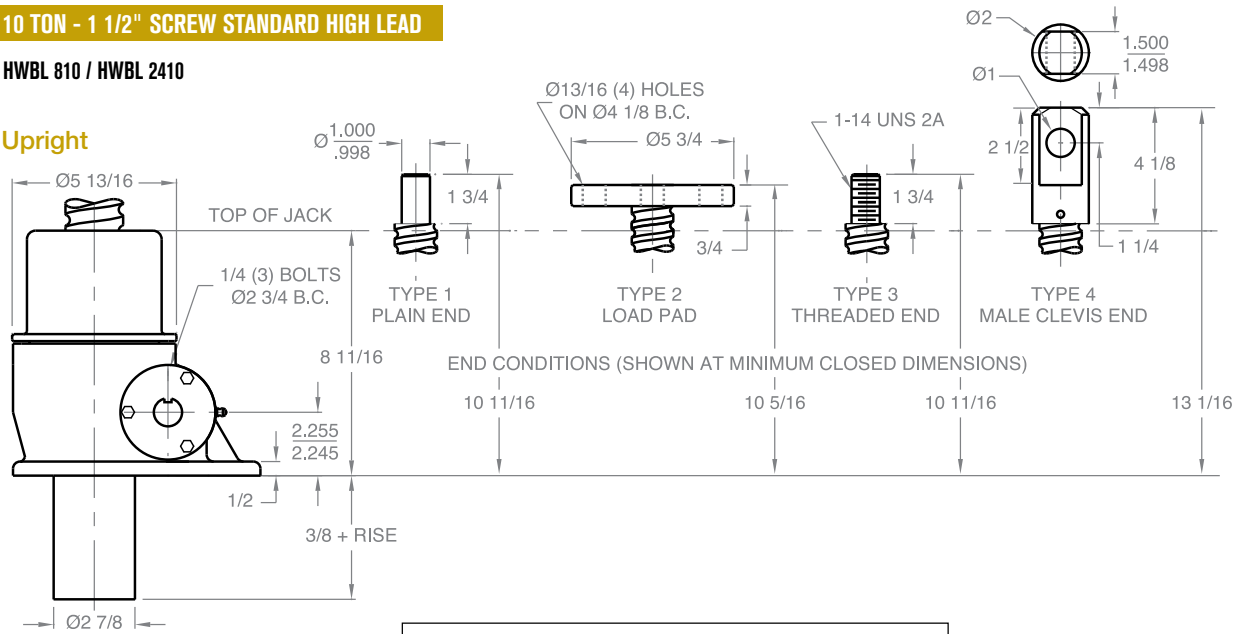

### Upright traveling nut

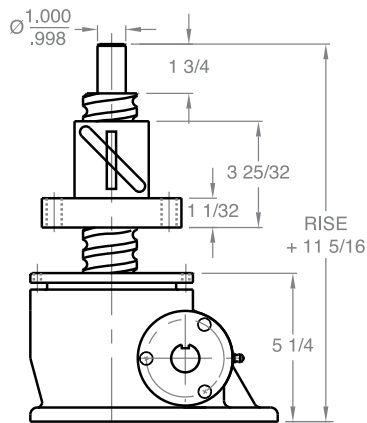

### Inverted

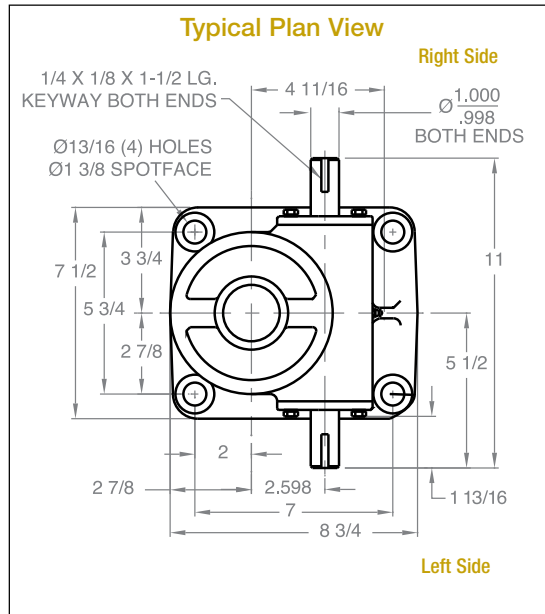
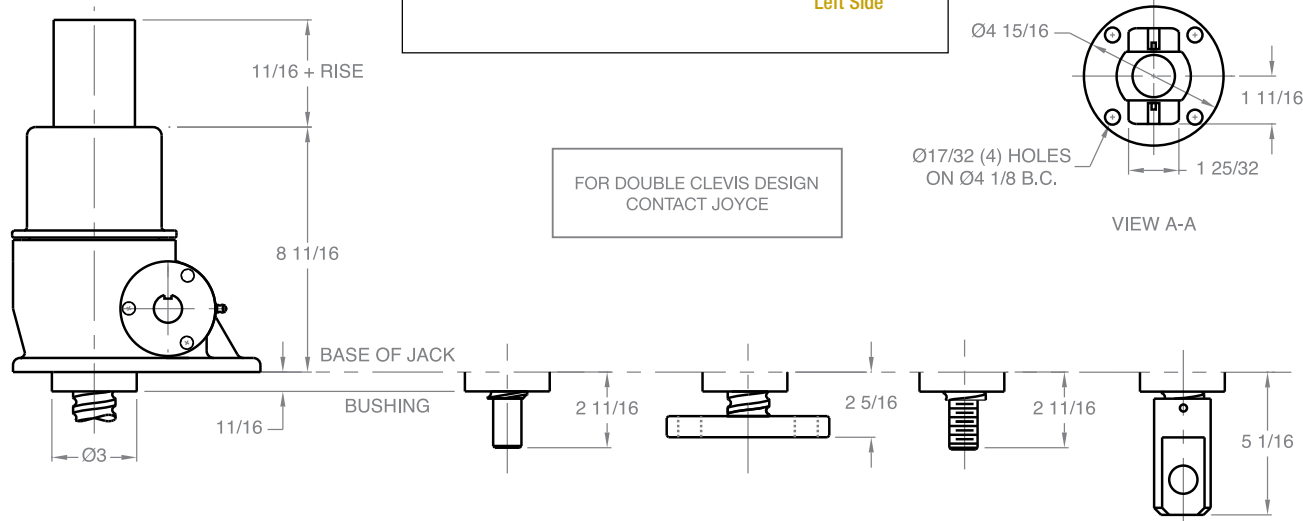

### Inverted traveling nut

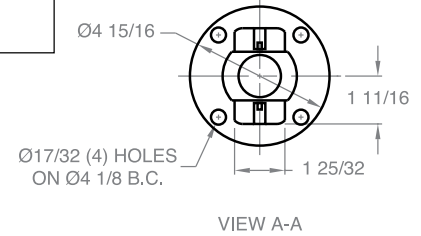
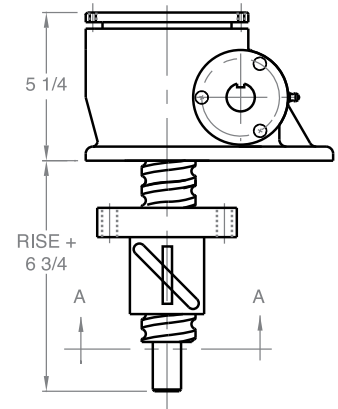

Note: Drawings are artist's conception — not for certification; dimensions are subject to change without notice.

# BALL SCREW JACKS

## 10 TON - 2" SCREW HEAVY DUTY

WB 810 / WB 2410

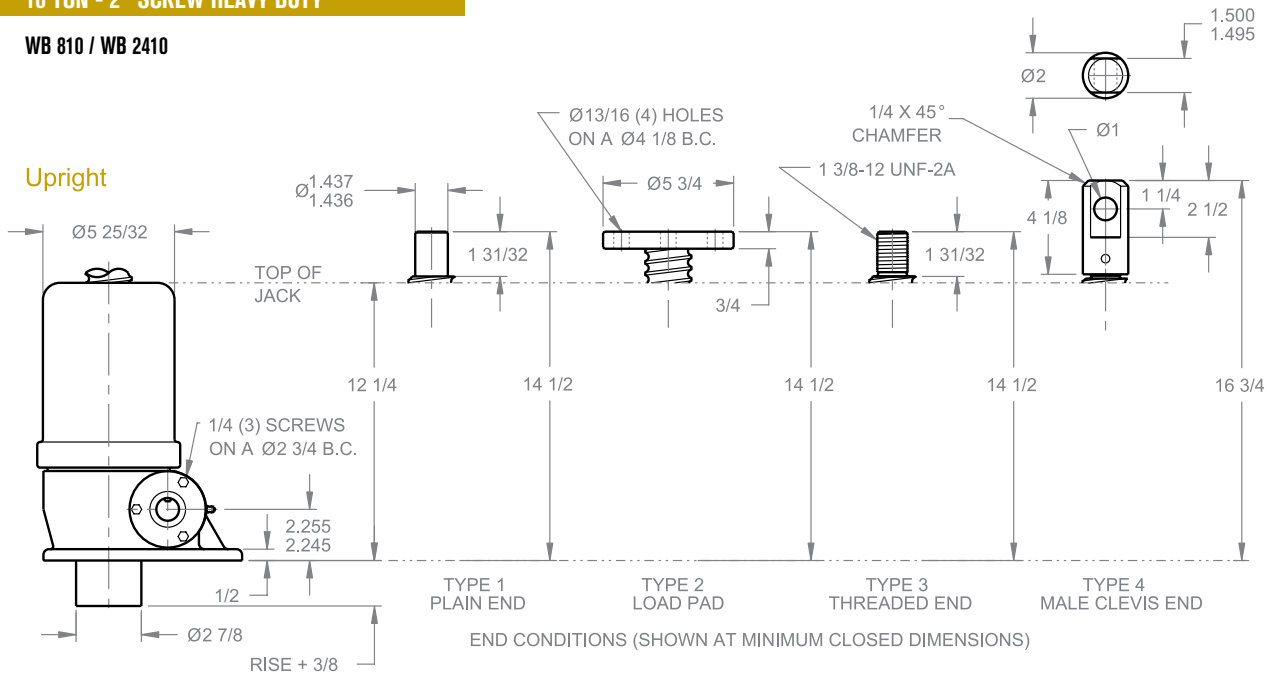

### Upright traveling nut

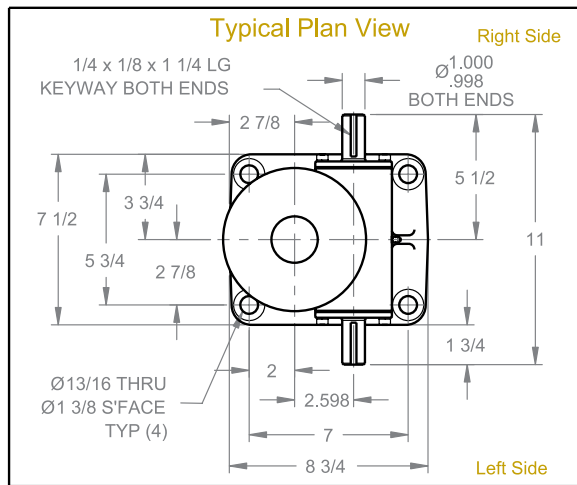
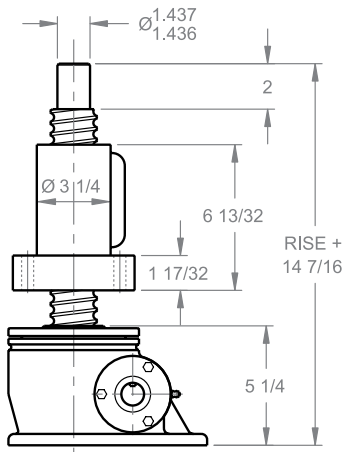

### Inverted traveling nut

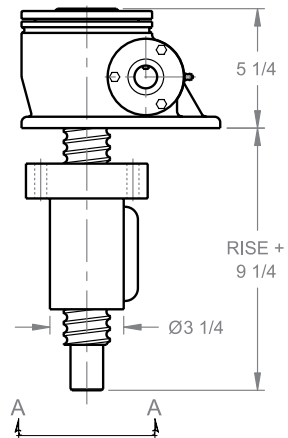

### Inverted

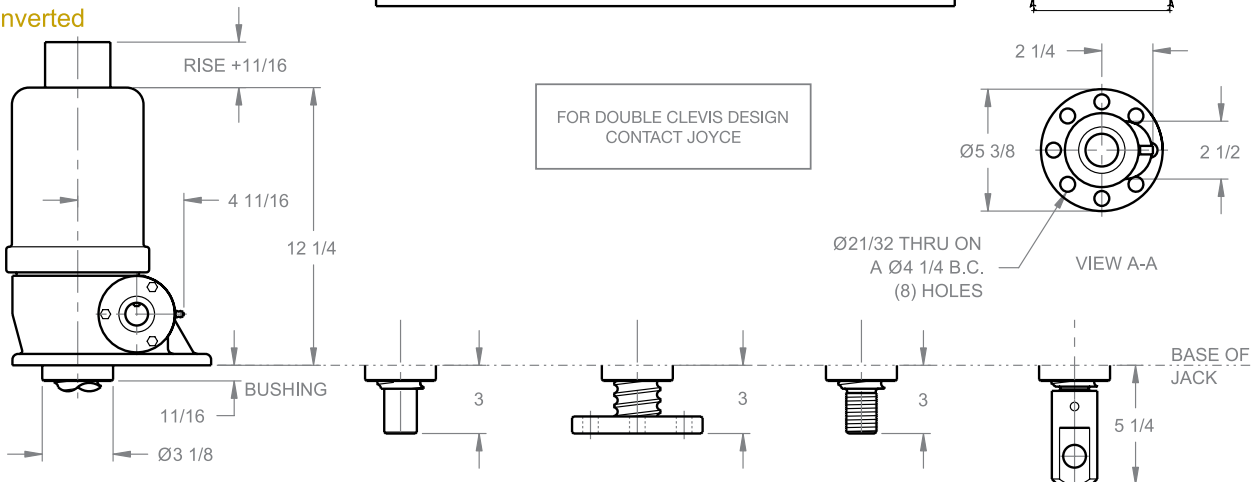

Note: Drawings are artist's conception — not for certification; dimensions are subject to change without notice.



# BALL SCREW JACKS

## 10 TON - 2" SCREW HEAVY DUTY HIGH LEAD

HWB 810 / HWB 2410

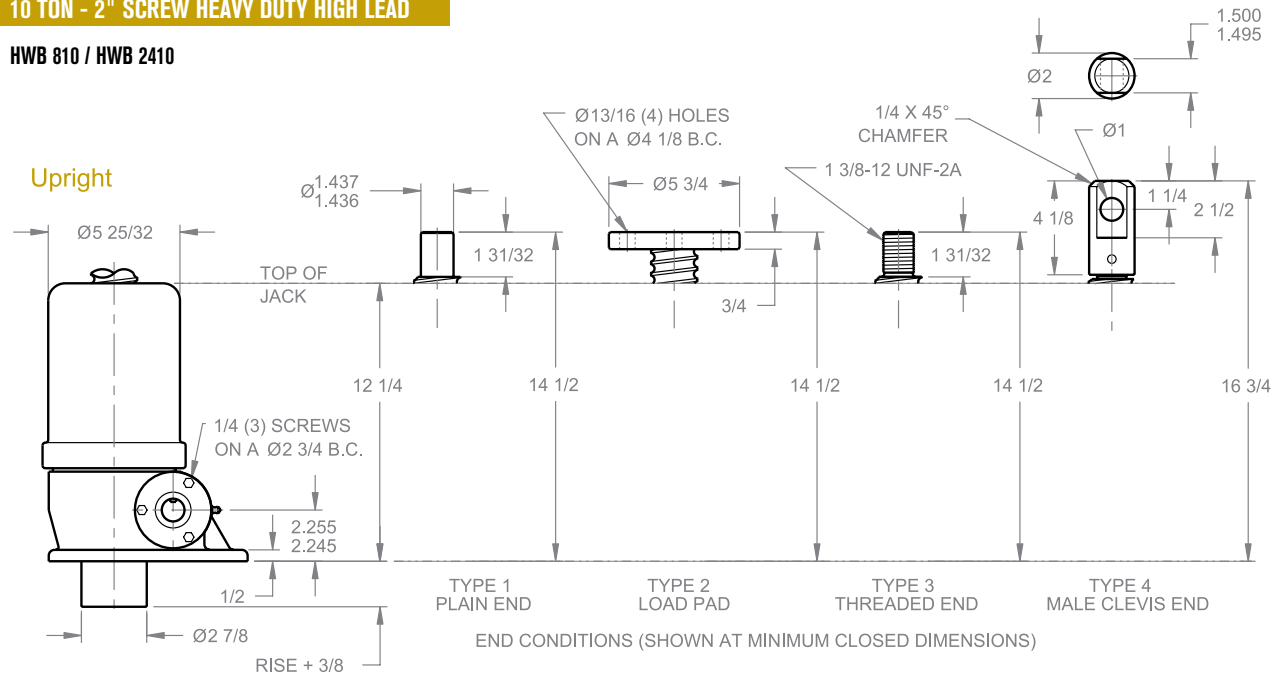

### Upright traveling nut

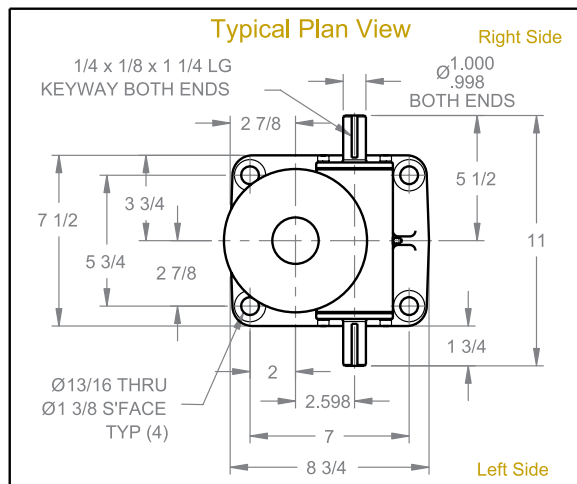
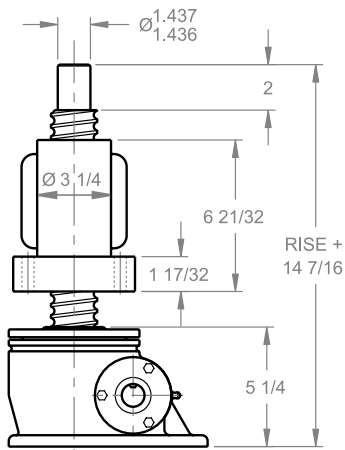

### Inverted traveling nut

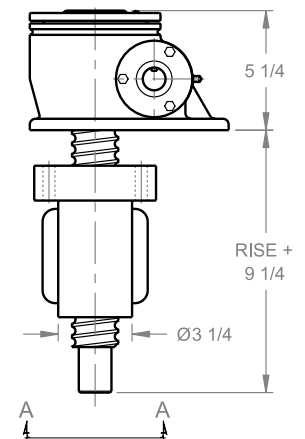

### Inverted

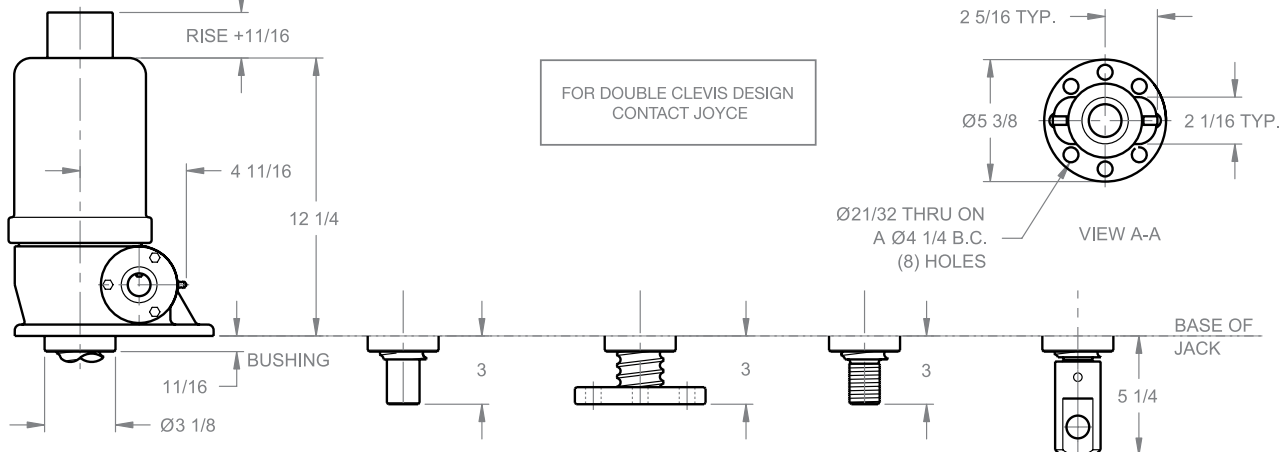

Note: Drawings are artist's conception — not for certification; dimensions are subject to change without notice.

# BALL SCREW JACKS

20 TON - 2 1/4" SCREW STANDARD

WB 820 / WB 2420

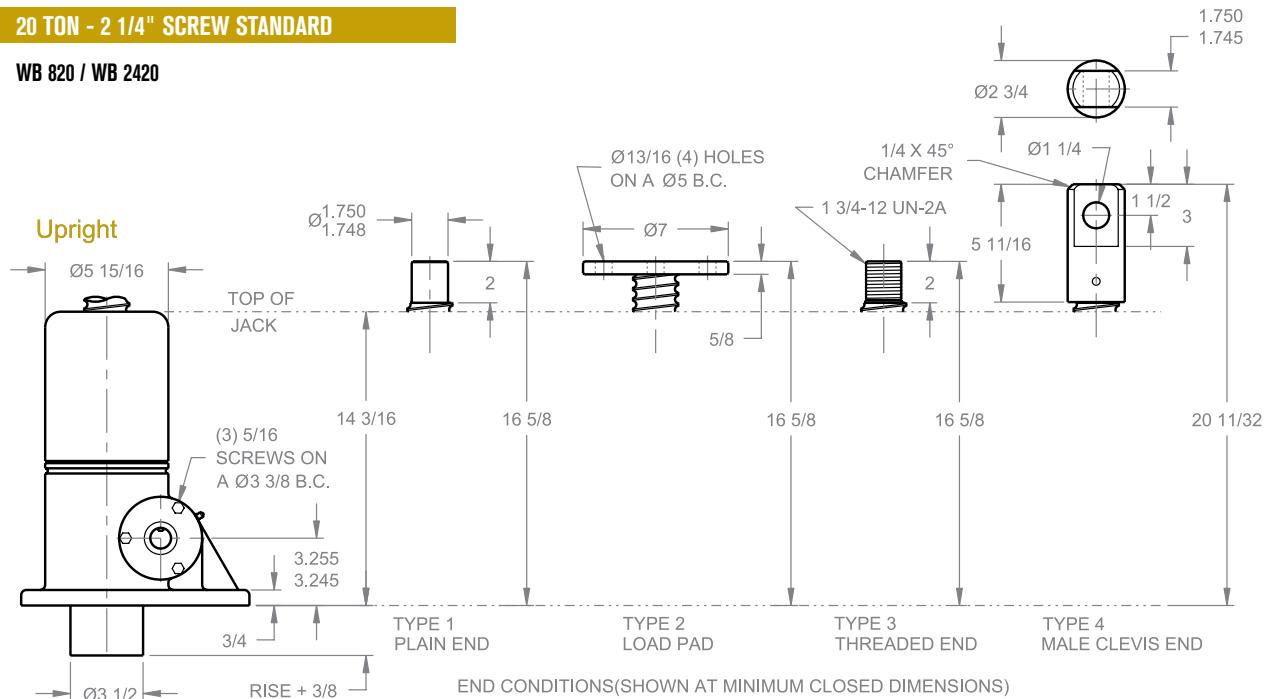

## Upright traveling nut

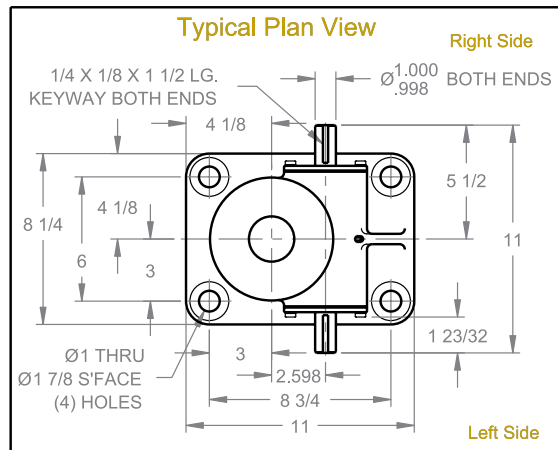
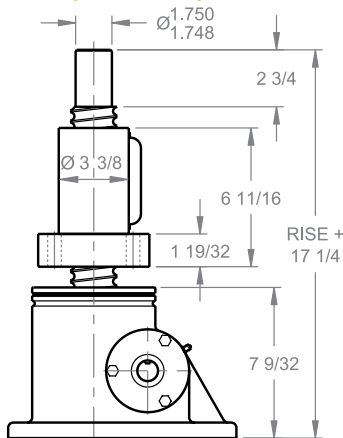

## Inverted traveling nut

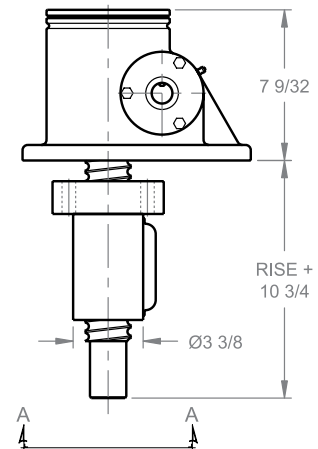

## Inverted

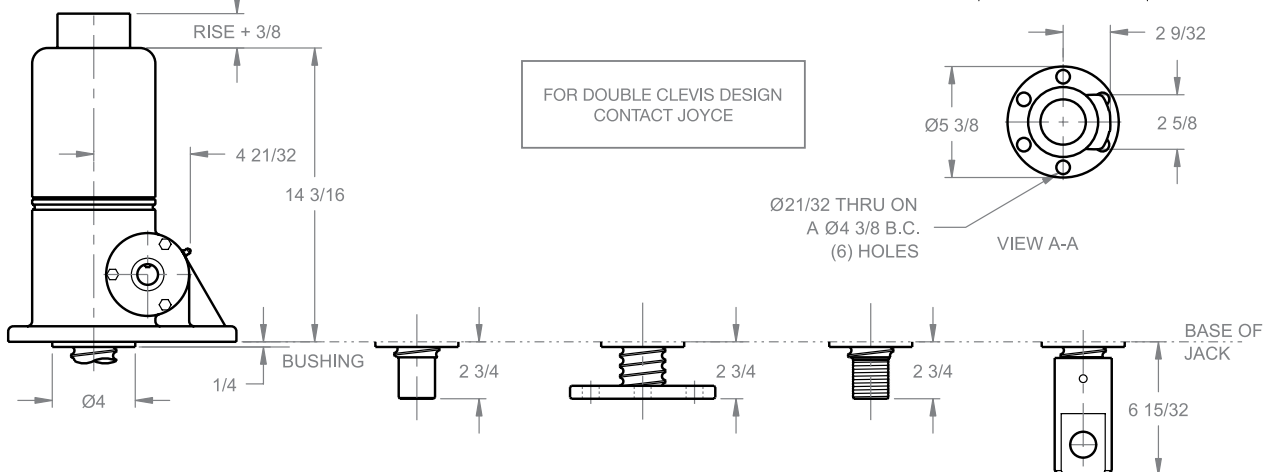

Note: Drawings are artist's conception — not for certification; dimensions are subject to change without notice.

# BALL SCREW JACKS

30 TON - 3" SCREW STANDARD

WB 1130 / WB 3230

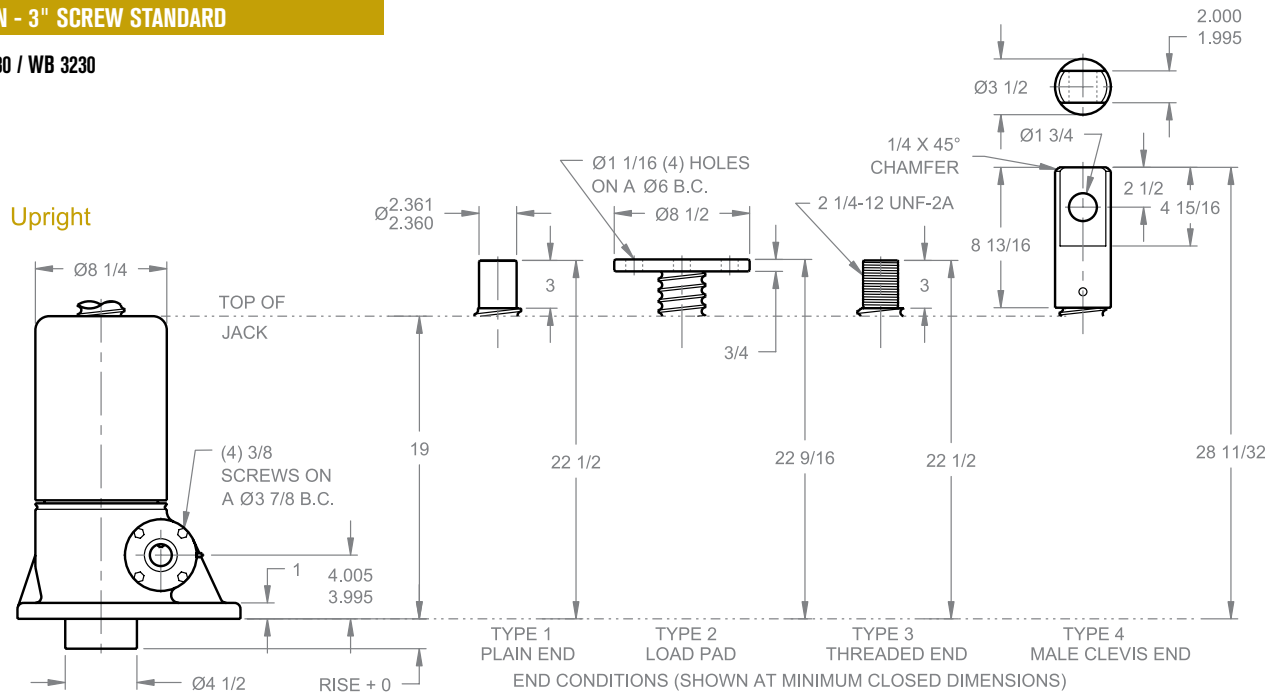

**Upright traveling nut**

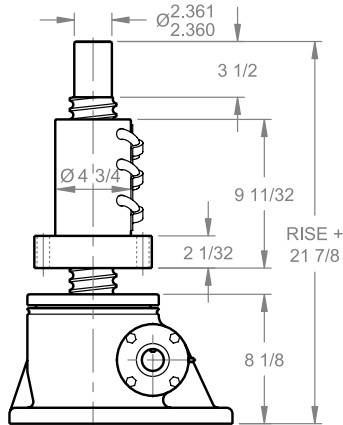

**Inverted traveling nut**

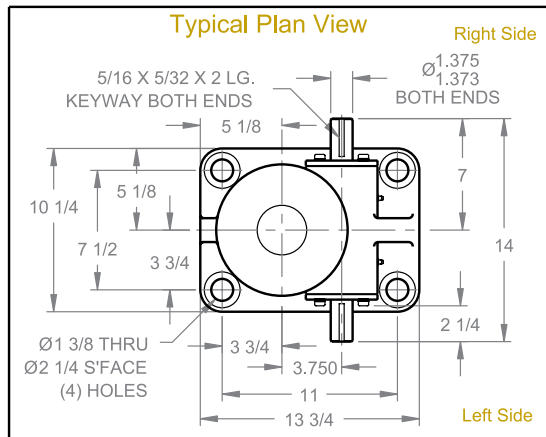
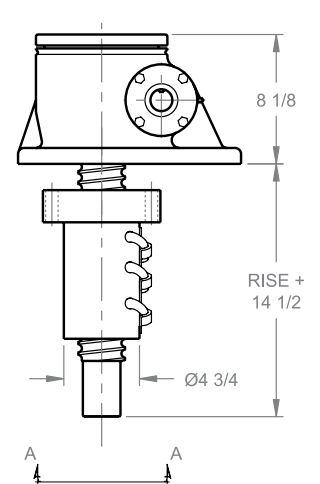

**Inverted**

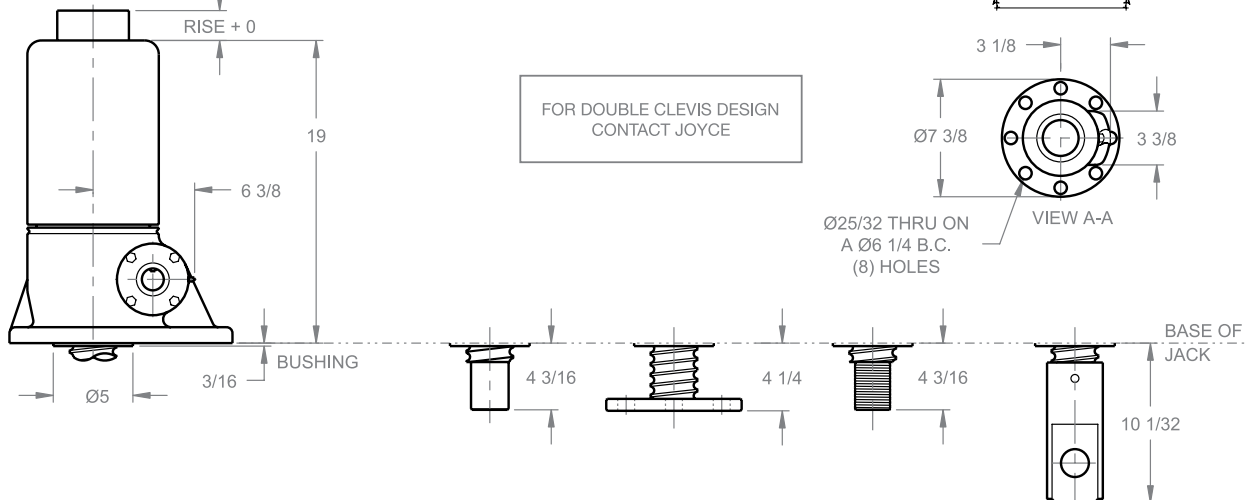

Note: Drawings are artist's conception — not for certification; dimensions are subject to change without notice.

# BALL SCREW JACKS

50 TON - 4" SCREW STANDARD

WB 1150 / WB 3250

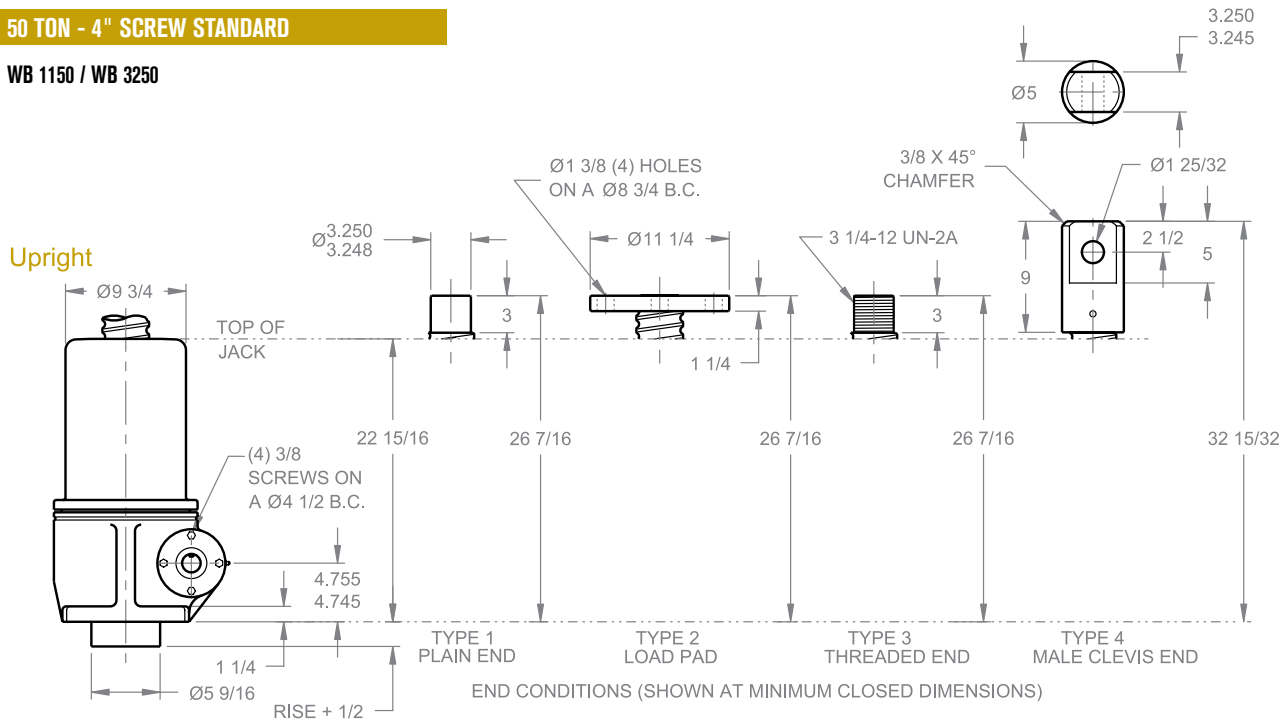

## Upright traveling nut

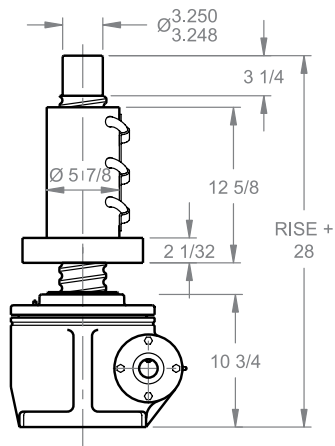

## Inverted traveling nut

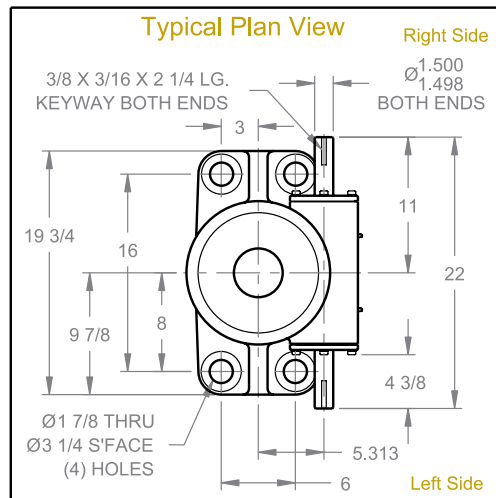
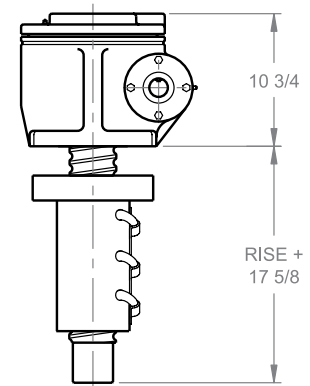

## Inverted

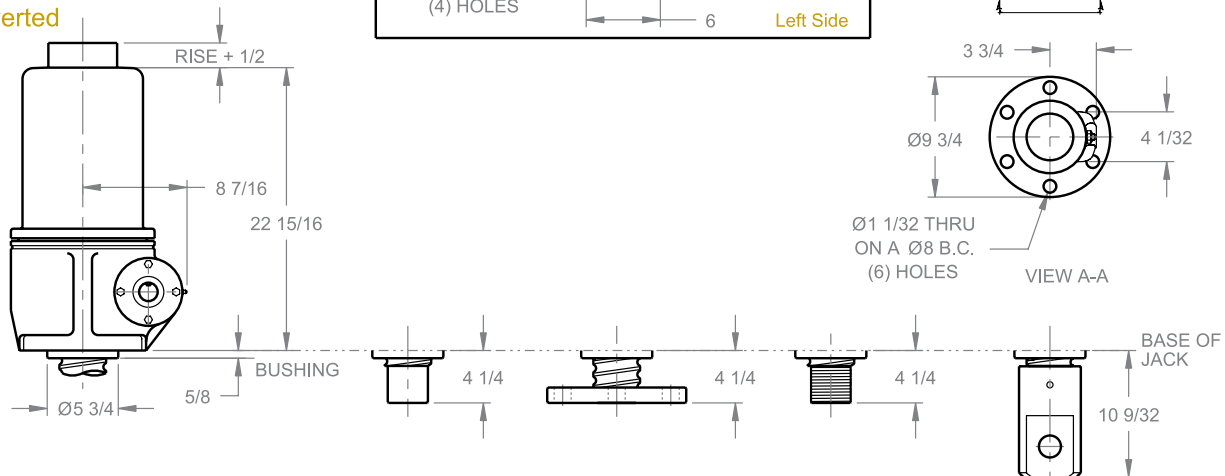

Note: Drawings are artist's conception — not for certification; dimensions are subject to change without notice.

# BALL SCREW JACKS

## 50 TON - 4" SCREW REVERSE BASE

RWB 1150 / RWB 3250

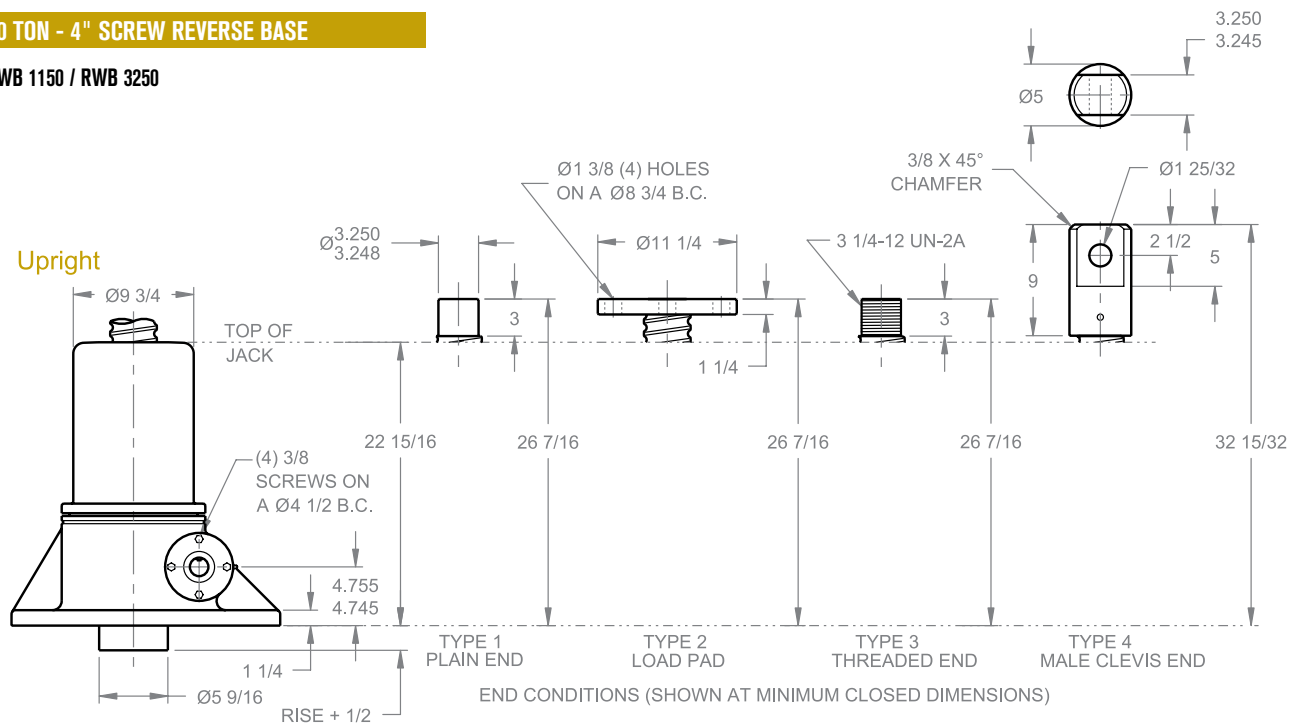

### Upright traveling nut

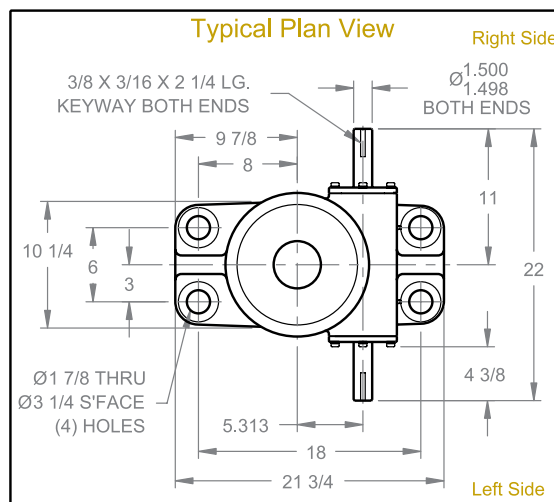
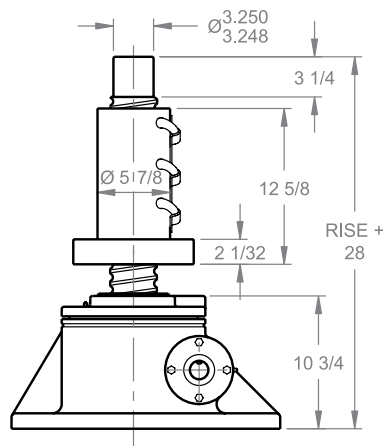

### Inverted traveling nut

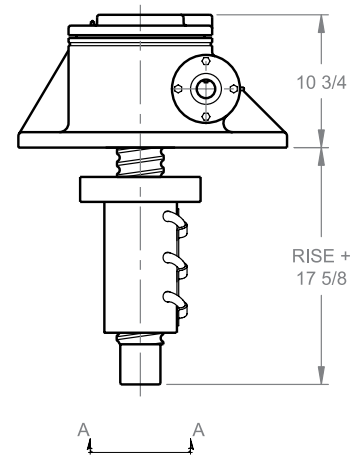

### Inverted

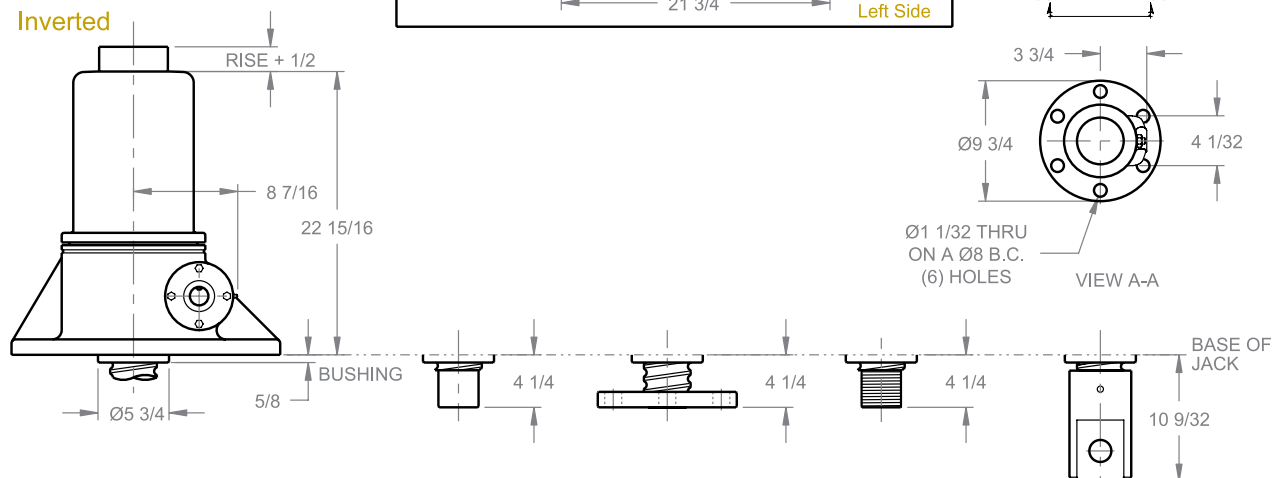

Note: Drawings are artist's conception — not for certification; dimensions are subject to change without notice.

Joyce ball screw ComDRIVES® combine a ball screw jack, motor and gear reducer into a single compact unit. Ball screw ComDRIVES are available in 2-ton through 30-ton capacities. They provide travel speeds up to 55.5 inches per minute. Ball screw ComDRIVES require up to two-thirds less input torque to move the load than a similarly sized machine screw ComDRIVE. They require a brake motor or external locking device to hold position.

Four standard end conditions are available and ball screw ComDRIVES can be fitted with protective boots. Limit switches, oversized ball bearings and other options are also available.

**Ball Screw ComDRIVE Benefits:**

- Can power an entire jacking system.
- Reduces the number of components that must be specified.
- Simplifies design.
- Reduces installation costs because only a single plate is needed to mount the jack body.
- Reduces the number of couplings and shafts required in multi-jack systems.
- Standard 230/460 volt, 3-phase, 60 hertz motor included (brake recommended).

Ball screw ComDRIVES can be specified without the motor and the reducer flange accepts standard NEMA motor frame sizes.

Joyce can customize ball screw ComDRIVES to meet your specifications. Ask about larger size ComDRIVES.

**Joyce offers Ball Screw ComDRIVES in several designs including:**

- **Translating**
- **Keyed for traveling nut (KFTN)**
- **Double clevis**
- **Trunnion mount**

A guide for ordering is on pages 104 and 105.

# BALL SCREW ComDRIVES®



# BALL SCREW ComDRIVES® ORDERING INFORMATION

**Instructions:** Select a model number from this chart.

2-Ton Standard	5-Ton Standard	10-Ton Standard	10-Ton Heavy Duty	20-Ton Standard	30-Ton Standard
CDB62 CDB122 CDB242	CDB65 CDB125 CDB245	CDBL810 CDBL2410	CDB810 CDB2410	CDB820 CDB2420	CDB1130 CDB3230
2-Ton High Lead	5-Ton High Lead	10-Ton Standard High Lead	10-Ton Heavy Duty High Lead		
CDHB62 CDHB122 CDHB242	CDHB65 CDHB125 CDHB245	CDHBL810 CDHBL2410	CDHB810 CDHB2410		

**Important Note:** Not self-locking, may lower under load. Brake motors or external locking systems are required.

**H:** High lead (2-ton, 5-ton and 10-ton only).

Sample Part Number: **CDHB65U1N-18.50-STDX-P3AE-M2**

### Jack Configuration

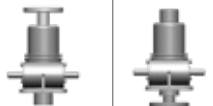

U=Upright I=Inverted

### End Conditions



1=T1 (plain end)  
2=T2 (load pad)  
3=T3 (threaded end)  
4=T4 (male clevis)

### Left Side Shaft Code

(see below)



XXXX=Remove  
STDX=Standard  
CUST=Custom  
For optional shaft codes, see page 105.

### Right Side Shaft Code

(see below)



XXXX=Remove  
STDX=Standard  
CUST=Custom  
For optional shaft codes, see page 105.

### Additional Options\*

X=Standard Jack, no additional options

S=Additional Specification Required (comment as necessary)

**Protective Boots**  
pp. 171-173  
B=Protective Boot  
D=Dual Protective Boot

**Finishes p. 182**  
F1=Do Not Paint  
F2=Epoxy Paint  
F3=Outdoor Paint Process

**Motor Options**  
M1=Less Motor  
M2=Brake Motor  
M3=Single Phase Motor (120VAC)  
M4=50Hz Motor  
M5=Special Motor

**Grease/Seals**  
H1=High Temperature Operation  
H2=Food Grade

**Screw Stops**  
Extending Stops are standard on ball screw ComDRIVES

\* Specify as many options as needed

**Ball Screw ComDRIVE® Rise**  
Rise is travel expressed in inches and not the actual screw length.

### Jack Designs



S=Translating K=Keyed for Non Rotation\*\* N=Traveling Nut D=Double Clevis A=KFTN Trunnion\* T=Trunnion\*

\*Standard trunnion mounts available on 2-ton through 20-ton jacks. (See page 183)

\*\*Keyed for non-rotation is not a standard option. Contact Joyce.



# BALL SCREW ComDRIVES® SHAFT CODES

**Instructions:** Select the appropriate shaft codes for both right and left hand shafts. One shaft code must be specified for each side of the ComDRIVE®.

## Screw Stops (p. 10) and Boots (pp. 171-173)

Extending screw stops are standard on ball screw ComDRIVES and they are not adjustable. When boots are added to ball screw ComDRIVES, the closed height of the jack may be increased.

## Geared Potentiometers (p. 175)

- POTA=0-10V
- POTB=4-20mA
- POTC=0-10V w/2 switches
- POTD=4-20mA w/2 switches
- IP65 rated enclosures



## Encoders (pp. 176-177)

- ENCA=Absolute Encoder 0-10 VDC, programmable
- ENCB=Absolute Encoder 4-20mA, programmable
- ENCC=Absolute Encoder CAN Open
- ENCD=Absolute Encoder SSI
- ENCS=Stainless Steel Incremental Encoder 1024 PPR
- ENCX=Incremental Encoder 200 PPR
- ENCY=Incremental Encoder 1024 PPR



## ComDRIVE Reducers (pp. 107-117)

Ordering Example: **P2AC**

Motor code from chart at right

### Mounting Positions

Code	P1	P2	P3	P4	Ratio
Left Side Shaft Positions					5:1 Code A
					7.5:1 Code B
					10:1 Code C
Right Side Shaft Positions					15:1 Code D
					Special Ratio Code X

### Motors

Size	Code
1/4 HP	K
1/3 HP	A
1/2 HP	B
3/4 HP	C
1 HP	D
1-1/2 HP	E
2 HP	F
3 HP	L
5 HP	G
7-1/2 HP	H

All standard motors are 3-phase, 208-230/460 VAC or 230/460 VAC. Other motor options are available including international voltages, and single phase AC. Specify the appropriate motor size from the chart above. Refer to the "Additional Options" chart on the preceding page as needed. Brake motors are required for ball screw ComDRIVES. Contact Joyce for options that are not listed.

## Mechanical Limit Switches (p. 174)

Ordering Example: **LA13**

Models		Number of DPDT Switches (see p. 174)	Available Positions							
Model	Code		1	2*	3	4	5	6*	7	8
LS7-402	LI	NOTE: Will always be 0 for LS7 models								
LS8-402	LA									
LS8-404	LB									

• 2, 5, 10, and 20-ton ball screw ComDRIVES are available with positions #1, #3, and #5.  
 • 30-ton ball screw ComDRIVES are available with positions #1, #4, #7 and #8.  
 \* These positions are not standard. Contact Joyce with your requirements.

**Ball Screw ComDRIVES<sup>®</sup> Column Loading Chart**

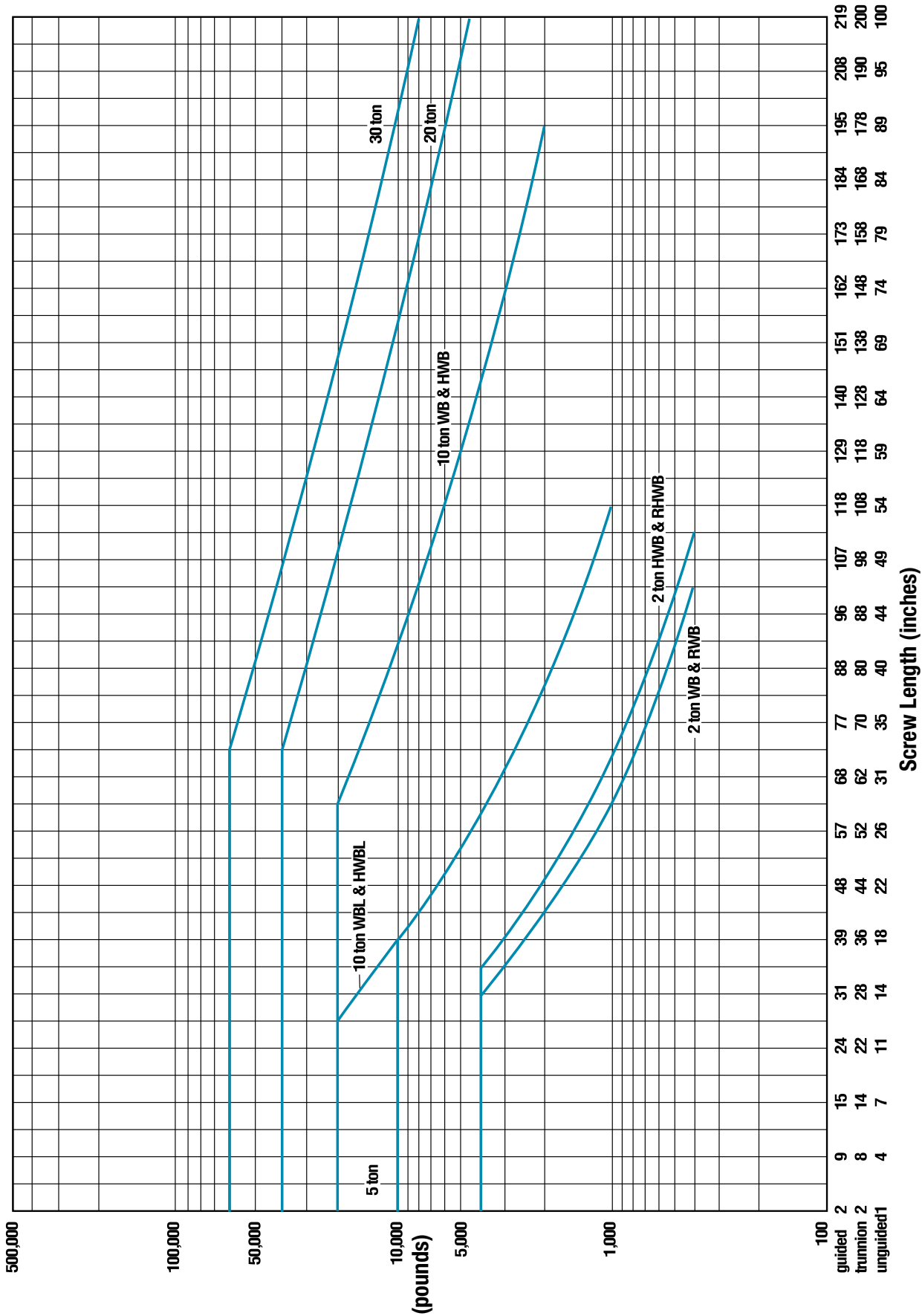

This chart includes a 2:1 Factor-of-Safety based on the Euler-Johnson equation for column loading (Oberg, Erik et al: Machinery's Handbook, 24th Edition, c. 1992 Industrial Press Inc.)  
 The horizontal portion of each line represents the jack's maximum dynamic capacity. Under static conditions, these lines can be exceeded. Please contact factory for assistance.

# BALL SCREW ComDRIVES<sup>®</sup> SPECIFICATIONS

2-Ton Model Number		CDB62			CDB122		CDB242			CDHB62			CDHB122	CDHB242		
Reducer Ratio		5	7 1/2	10	5	7 1/2	5	7 1/2	10	5	7 1/2	10	7 1/2	5	7 1/2	10
Travel Speed IPM		13.88	9.50	7.04	6.94	4.75	3.47	2.38	1.76	55.50	38.00	28.16	19.00	13.88	9.50	7.04
Lifting Capacity, Lbs.	1/3 HP	4,000	4,000	4,000	4,000	4,000	4,000	4,000	4,000	1,025	1,455	1,925	2,595	3,015	4,000	4,000
	1/2 HP									1,580	2,220	2,925	3,955	4,000		
	3/4 HP									2,400	3,375		4,000			

5-Ton Model Number		CDB65		CDB125	CDB245	CDHB65		CDHB125	CDHB245
Reducer Ratio		5	10	10	10	5	10	10	10
Travel Speed IPM		26.29	13.34	6.67	3.34	55.50	28.16	14.08	7.04
Lifting Capacity, Lbs.	1 HP	6,770	10,000	10,000	10,000	3,200	5,950	10,000	10,000
	1 1/2 HP	10,000				4,900			
	2 HP					6,600			

10-Ton Model Number		CDBL810		CDBL2410		CDHBL810		CDHBL2410	
Reducer Ratio		5	10	5	10	5	10	5	10
Travel Speed IPM		19.72	10.00	6.57	3.34	41.63	21.13	13.88	7.04
Lifting Capacity, Lbs.	1 HP	8,555	16,425	20,000	20,000	4,050	7,780	9,910	18,445
	1 1/2 HP	13,390				6,340		15,500	
	2 HP	18,210				8,625		20,000	
	3 HP	20,000	20,000			13,370	20,000		
	5 HP					20,000			

10-Ton Model Number		CDB810		CDB2410		CDHB810		CDHB2410	
Reducer Ratio		5	10	5	10	5	10	5	10
Travel Speed IPM		20.81	10.56	6.94	3.52	41.63	21.13	13.88	7.04
Lifting Capacity, Lbs.	1 HP	8,100	15,560	19,820	20,000	4,050	7,780	9,910	18,445
	1 1/2 HP	12,685		20,000		6,340		15,500	
	2 HP	17,255				8,625		20,000	
	3 HP	20,000	20,000			13,370	20,000		
	5 HP					20,000			

20-Ton Model Number		CDB820			CDB2420		
Reducer Ratio		5			10		
Travel Speed IPM		20.81			10.56		
Lifting Capacity, Lbs.	1 HP	6,965			14,285		
	1 1/2 HP	11,480			27,550		
	2 HP	15,980			38,360		
	3 HP	25,330			40,000		
	5 HP	40,000			40,000		

30-Ton Model Number		CDB1130			CDB3230		
Reducer Ratio		5			10		
Travel Speed IPM		20.60			10.46		
Lifting Capacity, Lbs.	3 HP	24,295			46,080		
	5 HP	42,165			60,000		
	7 1/2 HP	60,000			60,000		

**Important Note:** Ball Screw ComDRIVES are not self-locking. Brake motors or external locking systems are required.

# BALL SCREW ComDRIVES®

## 2 TON REVERSE BASE - 1" SCREW STANDARD

CDB 62  
CDB 122  
CDB 242

Upright

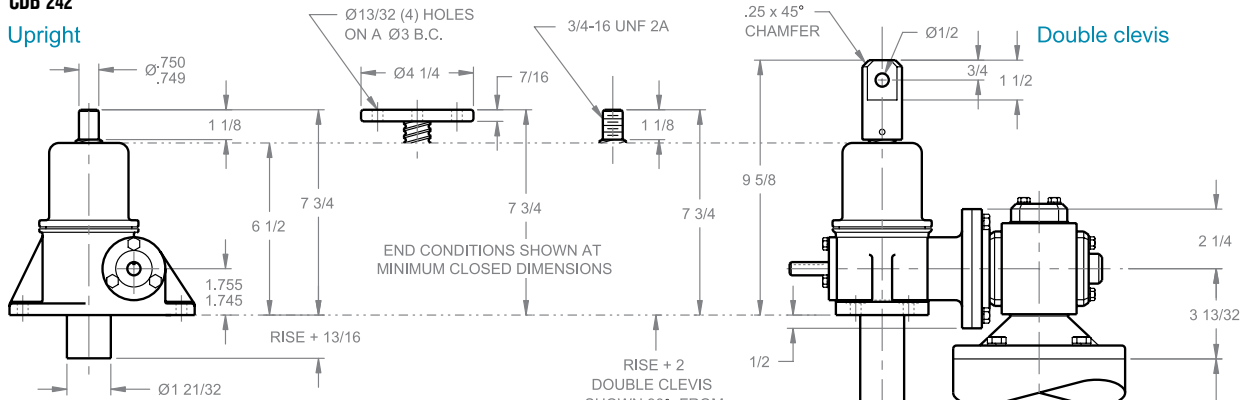

Upright traveling nut

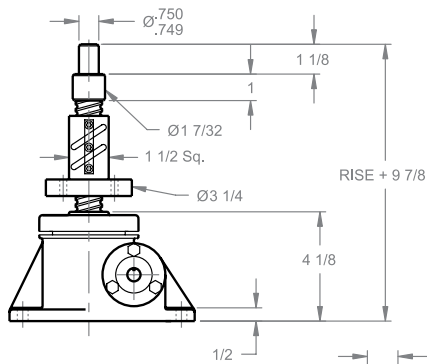

Inverted traveling nut

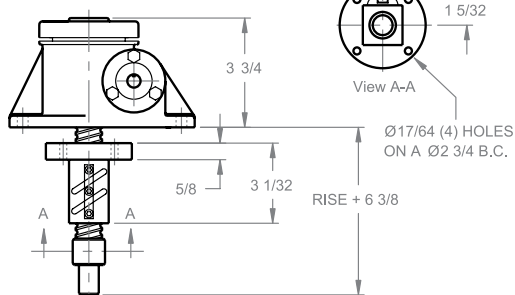

Inverted

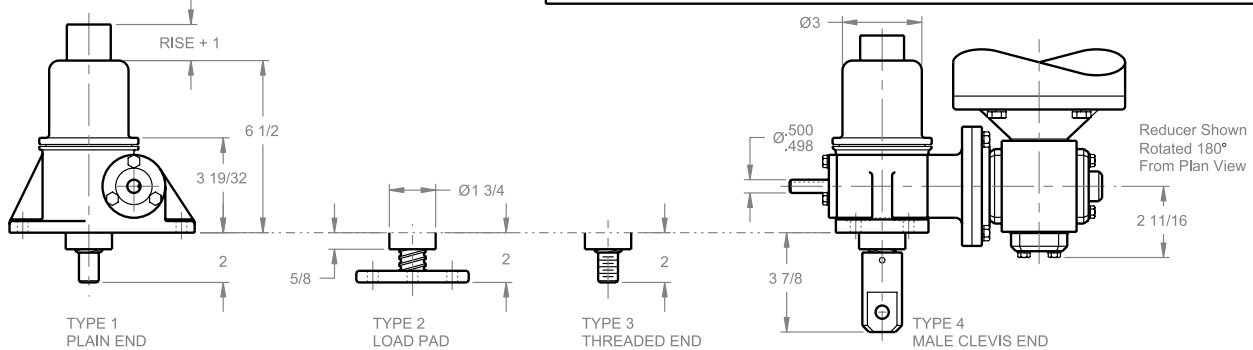

NOTE: FOR LIFTING CAPACITIES SEE PAGE 107.

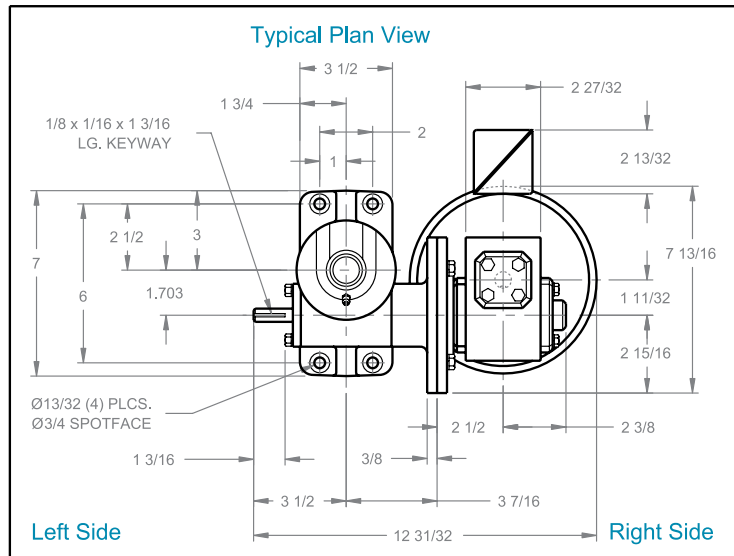

Note: Drawings are artist's conception — not for certification; dimensions are subject to change without notice.

# BALL SCREW ComDRIVES®

## 2 TON REVERSE BASE - 1" SCREW HIGH LEAD

CDHB 62  
CDHB 122  
CDHB 242

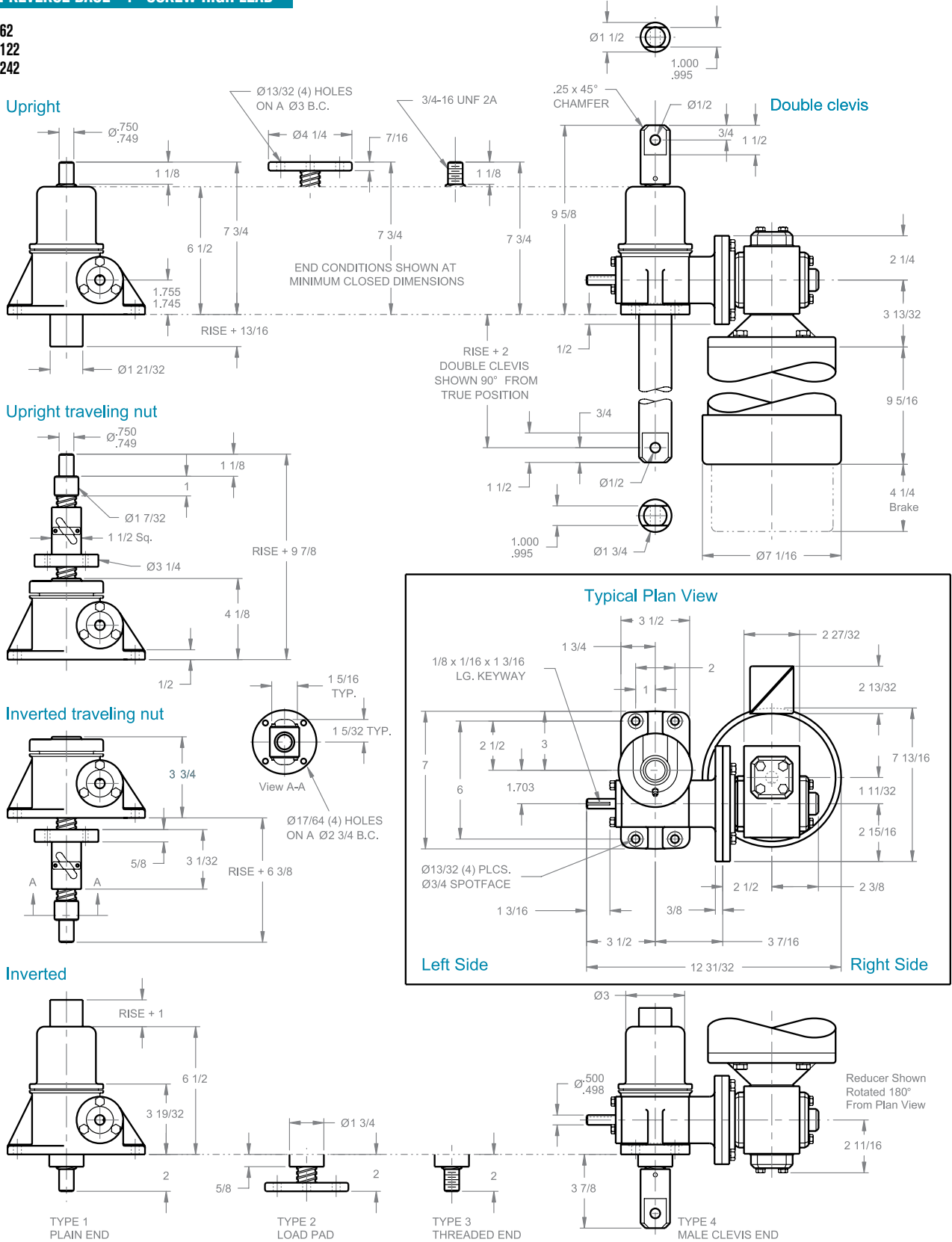

Note: Drawings are artist's conception — not for certification; dimensions are subject to change without notice.

# BALL SCREW ComDRIVES®

## 5 TON - 1 1/2" SCREW STANDARD

CDB 65  
CDB 125  
CDB 245

Upright

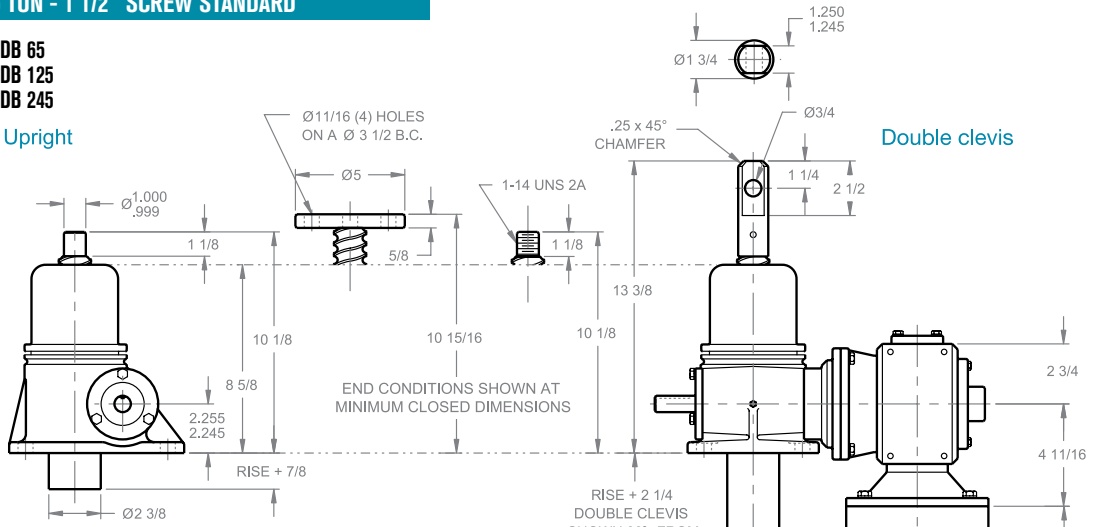

Upright traveling nut

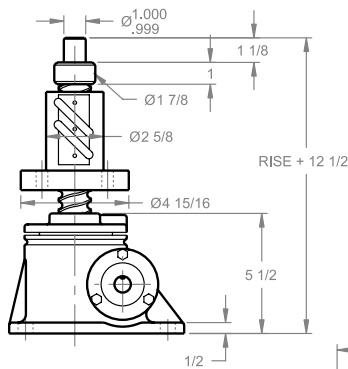

Inverted traveling nut

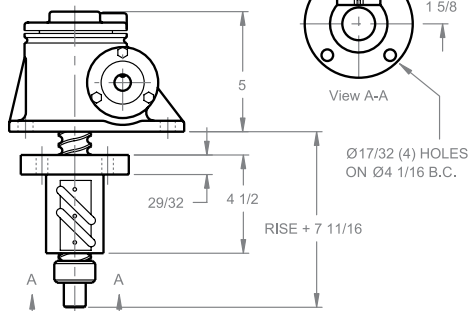

Inverted

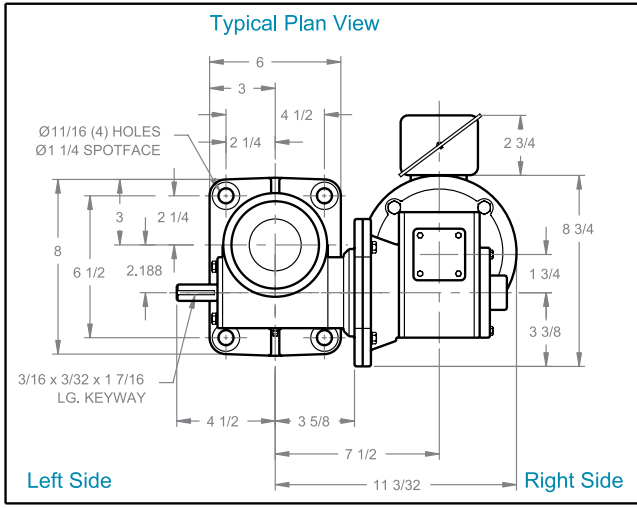
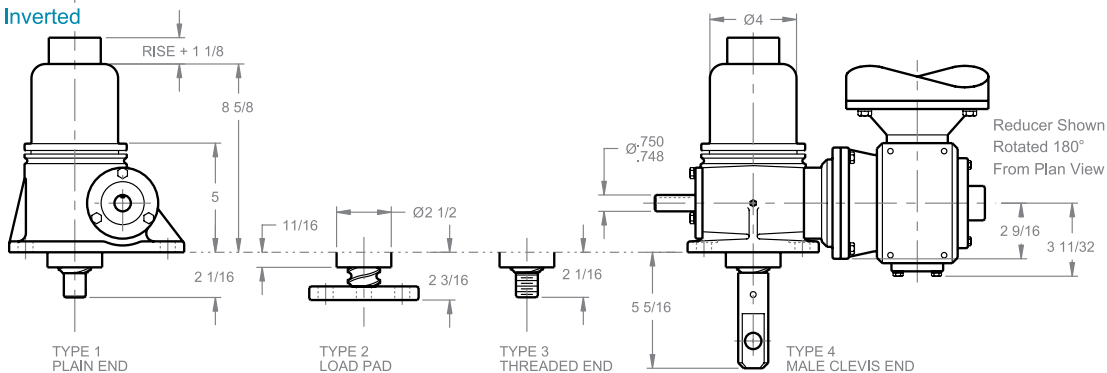

NOTE: FOR LIFTING CAPACITIES SEE PAGE 107.

Note: Drawings are artist's conception — not for certification; dimensions are subject to change without notice.

# BALL SCREW ComDRIVES®

## 5 TON - 1 1/2" SCREW HIGH LEAD

CDHB 65  
CDHB 125  
CDHB 245

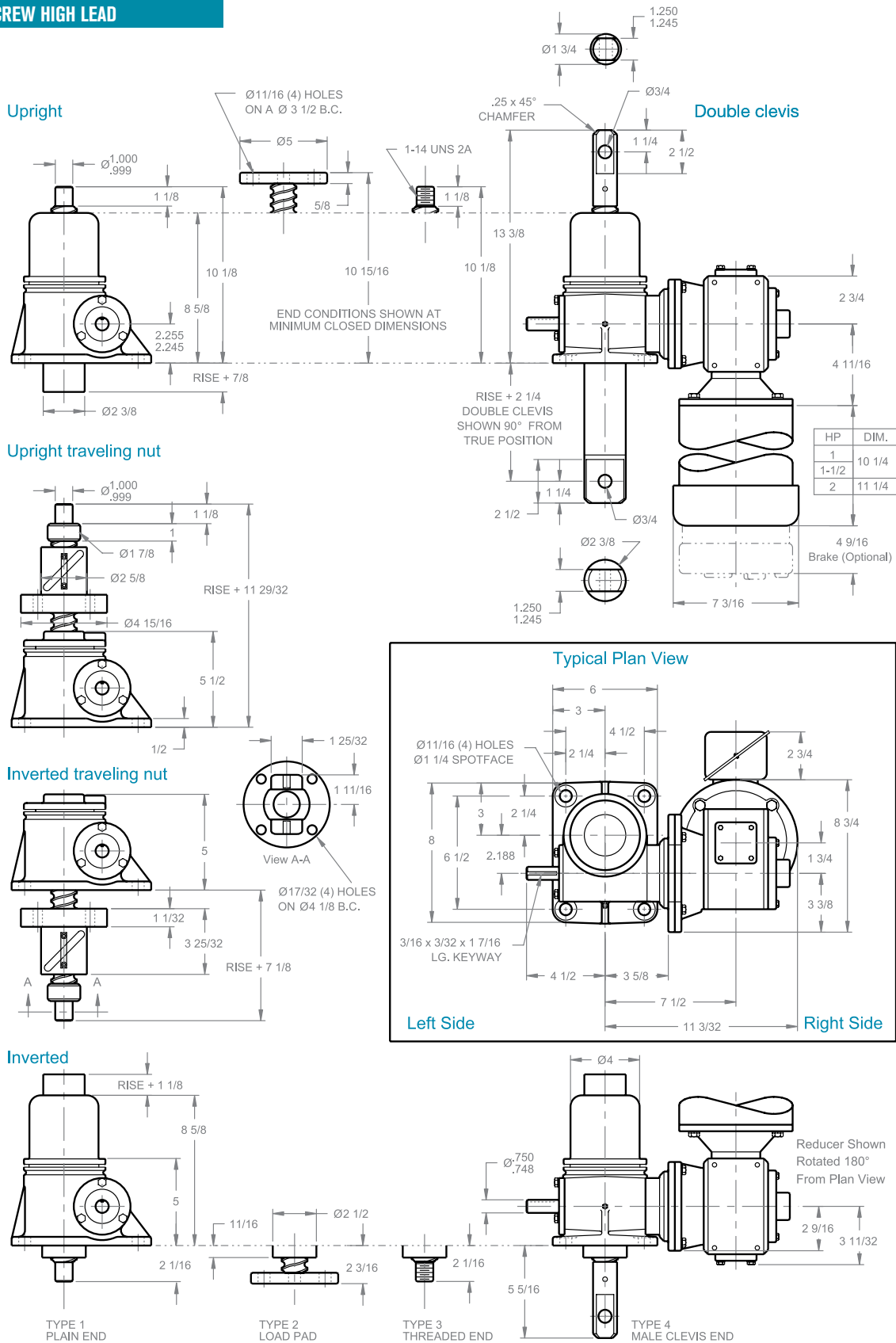

Note: Drawings are artist's conception — not for certification; dimensions are subject to change without notice.

# BALL SCREW ComDRIVES®

## 10 TON - 1 1/2" SCREW STANDARD

CDBL 810  
CDBL 2410

Upright

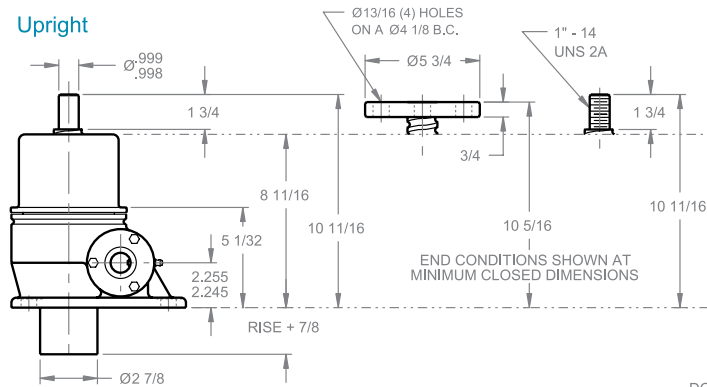

Double clevis

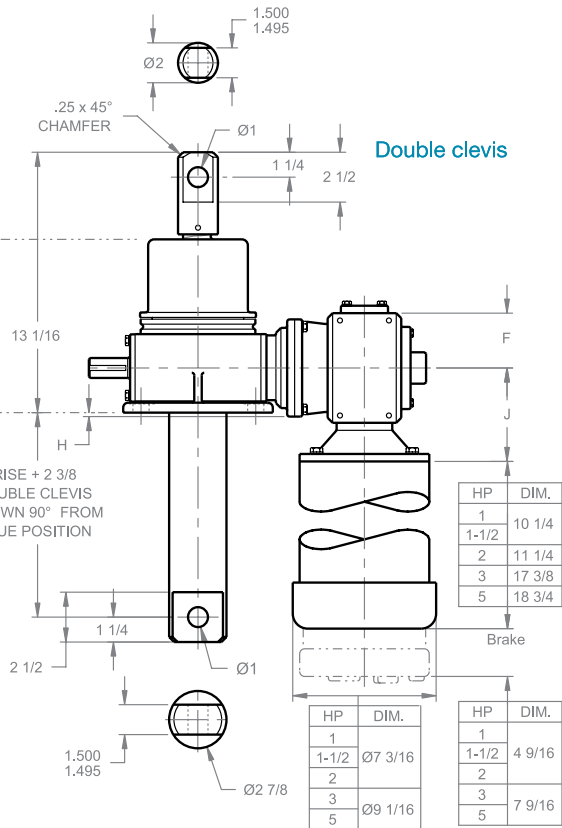

### REDUCER DIMENSIONS

HP	1, 1 1/2, 2	3, 5
A	8 11/32	8 29/32
B	11 21/32	13 17/32
C	1 3/4	2 5/8
D	3 3/8	4 7/16
E	8 7/16	11 11/16
F	2 3/4	3 7/8
G	4 15/32	4 15/32
H	0	1 1/8
J	4 11/16	5 3/4
K	3 11/32	4 5/16

HP	DIM.
1	10 1/4
1-1/2	
2	11 1/4
3	17 3/8
5	18 3/4

HP	DIM.
1	4 9/16
1-1/2	
2	
3	7 9/16
5	

Upright traveling nut

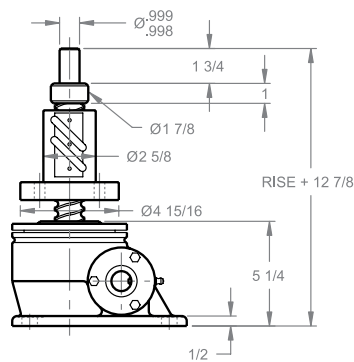

Inverted traveling nut

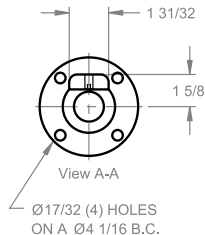
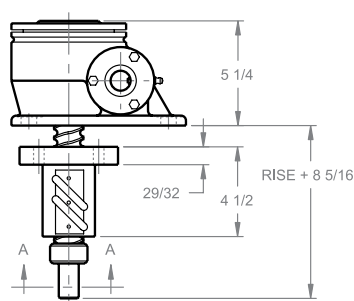

Typical Plan View

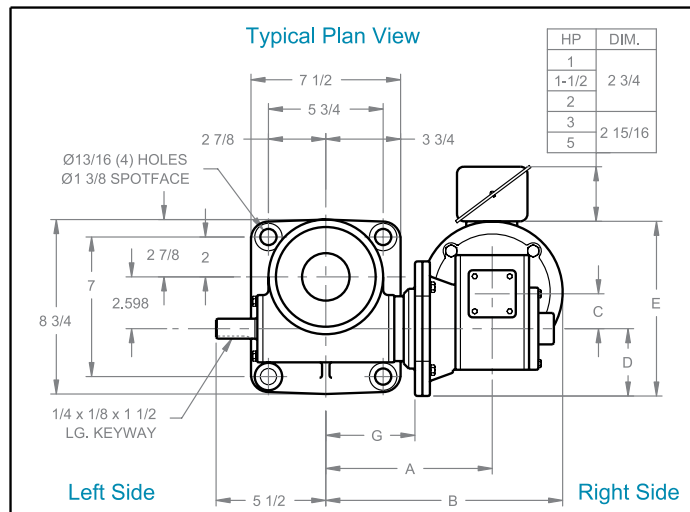

HP	DIM.
1	
1-1/2	2 3/4
2	
3	
5	2 15/16

Inverted

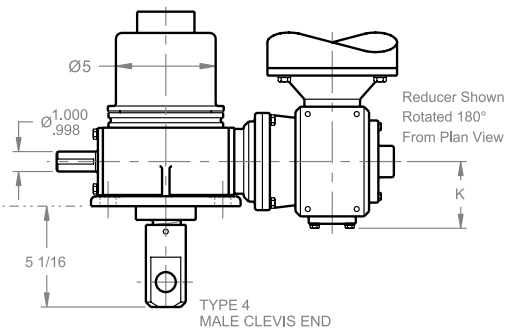
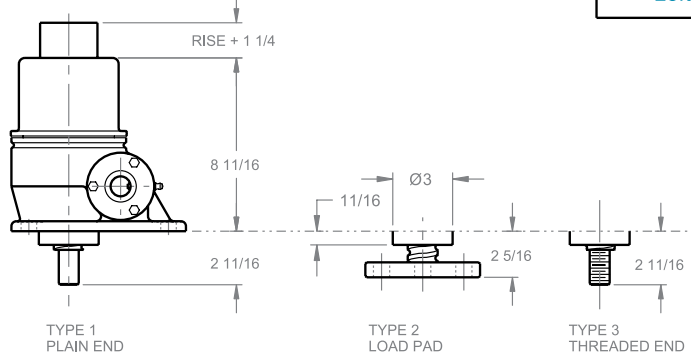

NOTE: FOR LIFTING CAPACITIES SEE PAGE 107.

Note: Drawings are artist's conception — not for certification; dimensions are subject to change without notice.



# BALL SCREW ComDRIVES®

## 10 TON - 1 1/2" SCREW STANDARD HIGH LEAD

CDHBL 810  
CDHBL 2410

### Upright

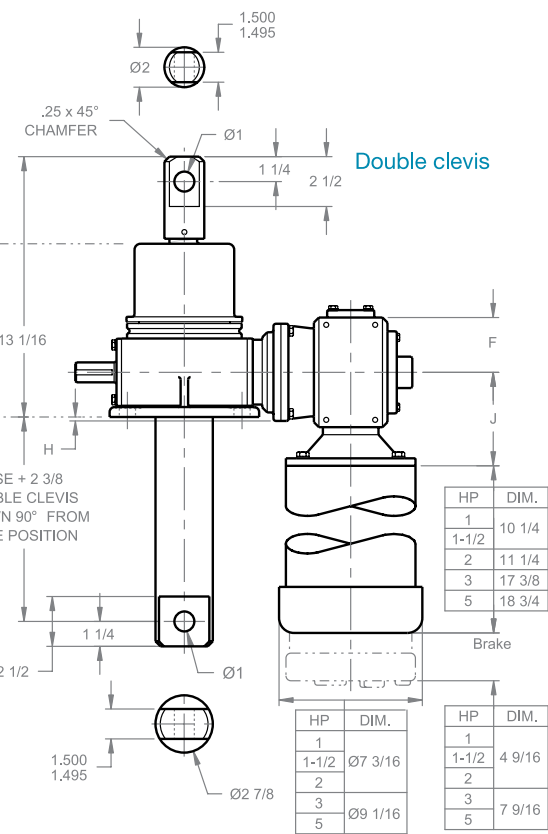
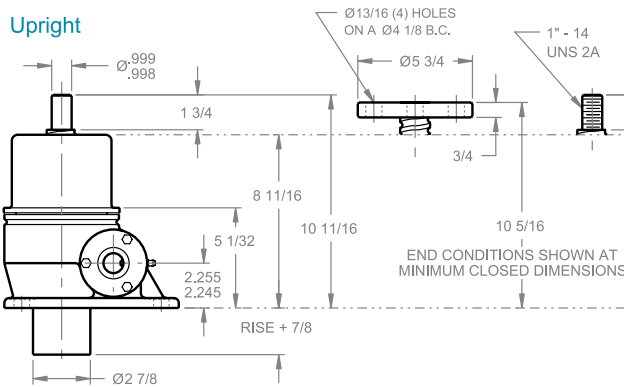

### REDUCER DIMENSIONS

HP	1, 1 1/2, 2	3, 5
A	8 11/32	8 29/32
B	11 21/32	13 17/32
C	1 3/4	2 5/8
D	3 3/8	4 7/16
E	8 7/16	11 11/16
F	2 3/4	3 7/8
G	4 15/32	4 15/32
H	0	1 1/8
J	4 11/16	5 3/4
K	3 11/32	4 5/16

### Upright traveling nut

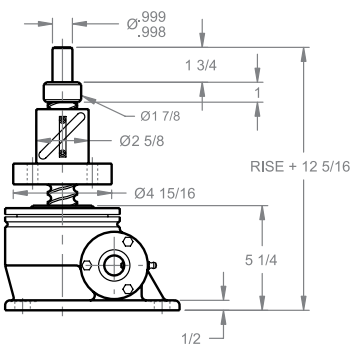

### Inverted traveling nut

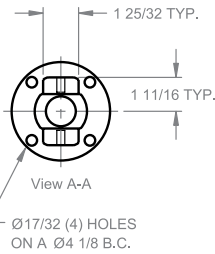
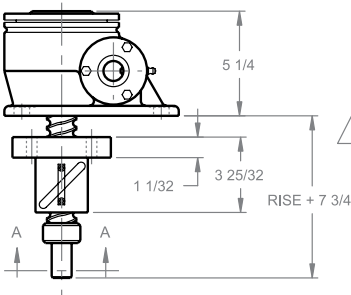

### Inverted

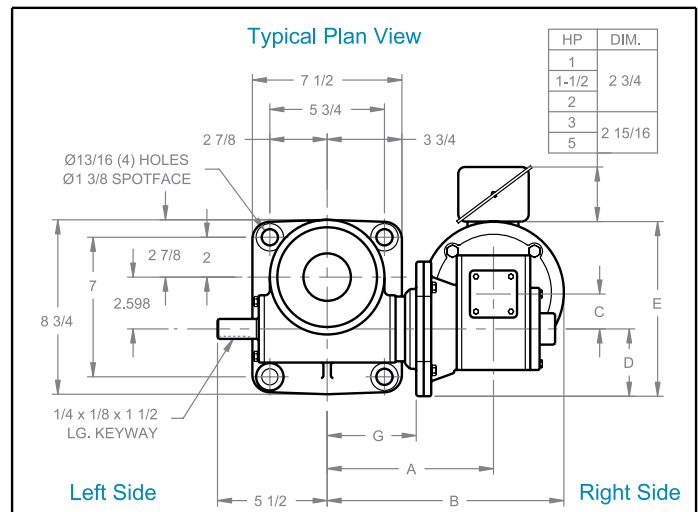
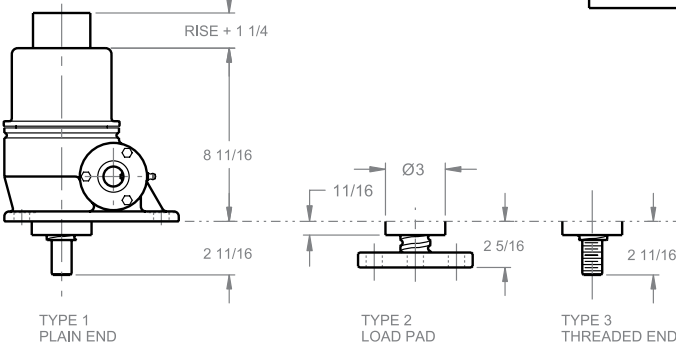

Left Side

Right Side

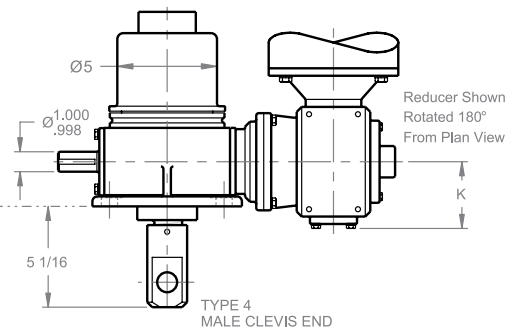

NOTE: FOR LIFTING CAPACITIES SEE PAGE 107.

Note: Drawings are artist's conception — not for certification; dimensions are subject to change without notice.

# BALL SCREW ComDRIVES®

## 10 TON - 2" SCREW HEAVY DUTY

CDB 810  
CDB 2410

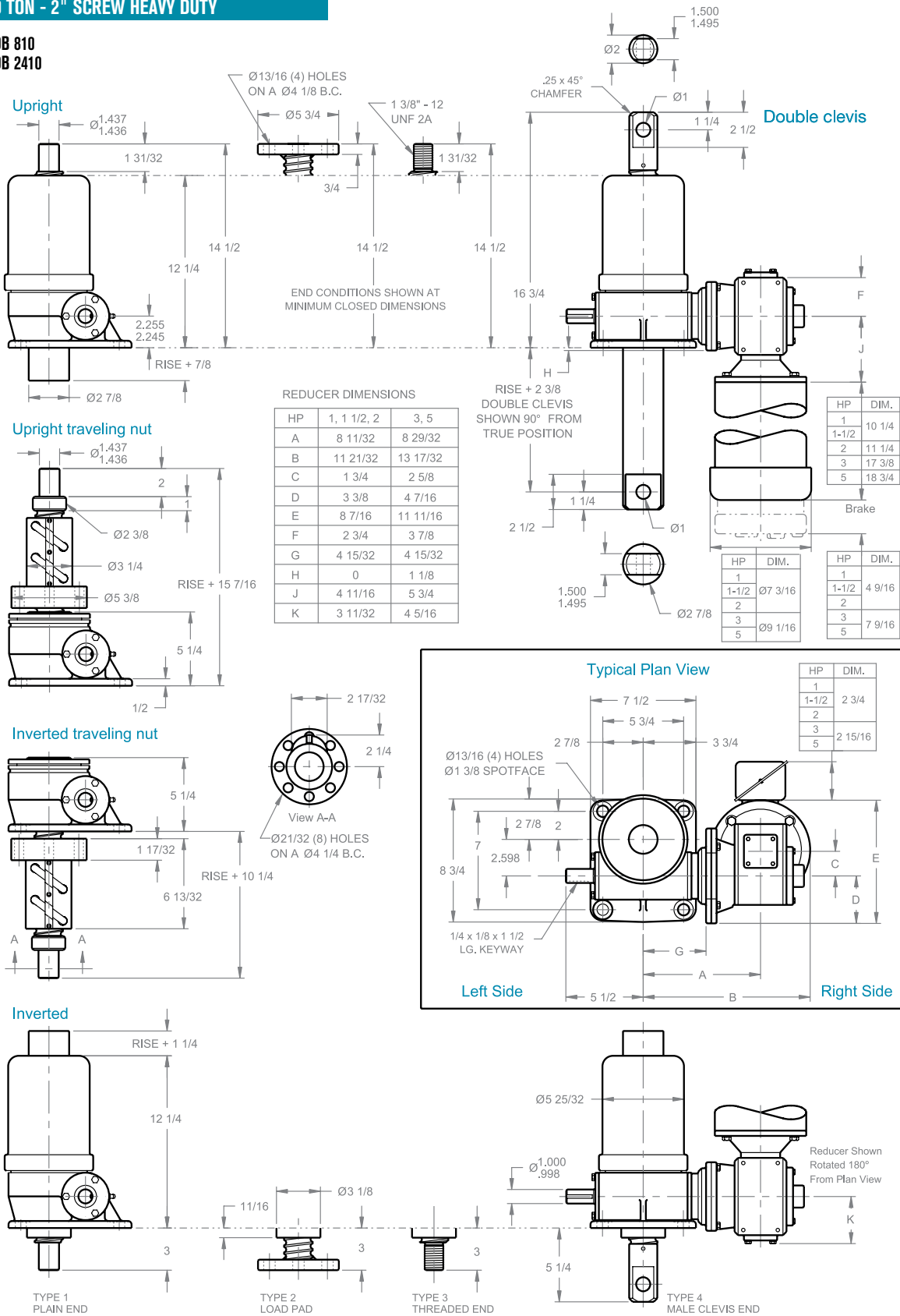

Note: Drawings are artist's conception — not for certification; dimensions are subject to change without notice.

# BALL SCREW ComDRIVES®

## 10 TON - 2" SCREW HEAVY DUTY HIGH LEAD

CDHB 810  
CDHB 2410

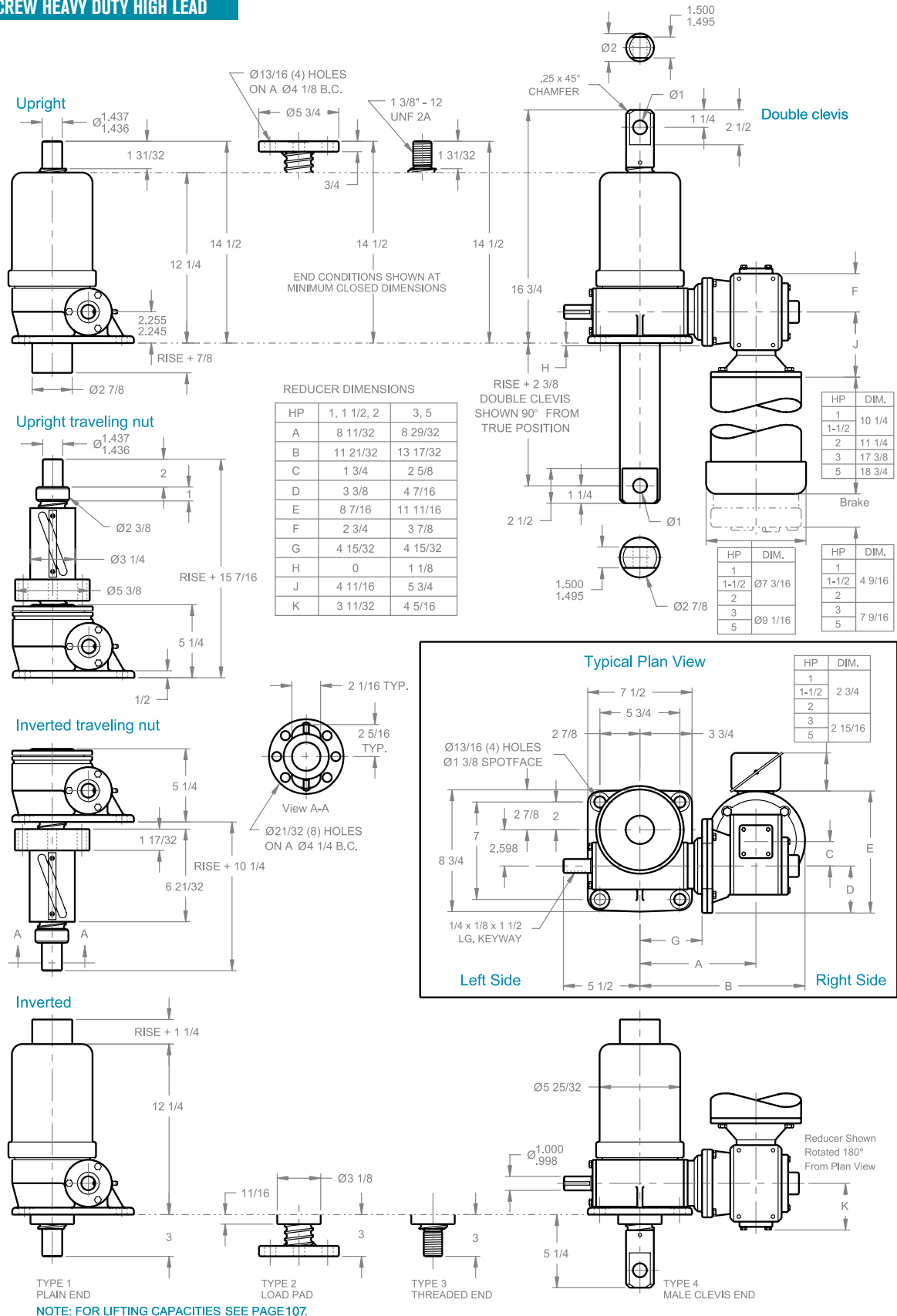

Note: Drawings are artist's conception — not for certification; dimensions are subject to change without notice.

# BALL SCREW ComDRIVES®

## 20 TON - 2 1/4" SCREW STANDARD

CDB 820  
CDB 2420

Upright

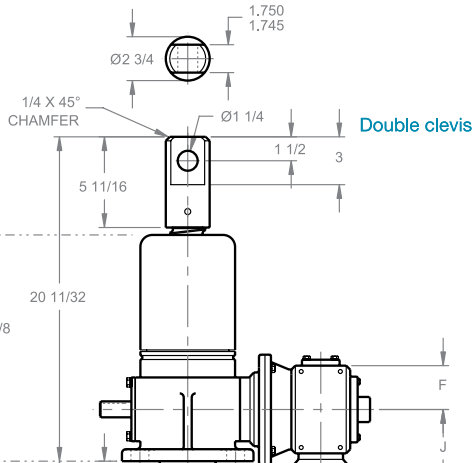
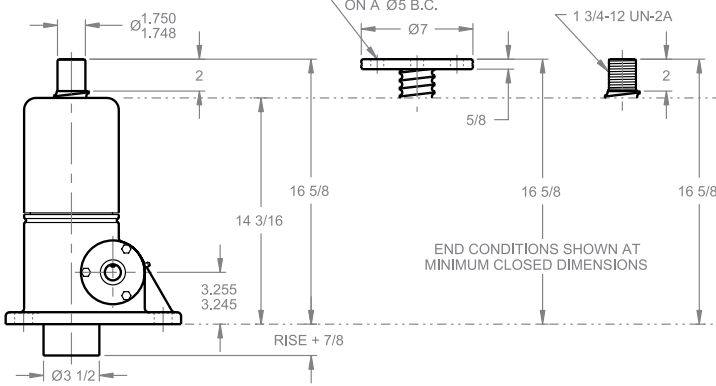

REDUCER DIMENSIONS

HP	1, 1 1/2, 2	3, 5
A	8 11/32	8 29/32
B	11 21/32	13 19/32
C	1 3/4	2 5/8
D	3 3/8	4 7/16
E	8 7/16	11 11/16
F	2 3/4	3 7/8
G	4 15/32	4 15/32
H	0	5/8
J	4 11/16	5 3/4
K	3 11/32	4 5/16

HP	DIM.
1	10 1/4
1-1/2	11 1/4
2	17 3/8
3	18 3/4

Brake (Optional)

HP	DIM.
1	1
1-1/2	4 9/16
2	2
3	7 9/16
5	5

Upright traveling nut

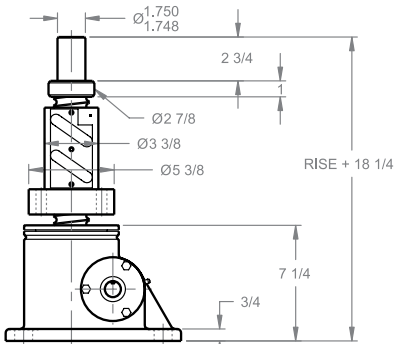

Inverted traveling nut

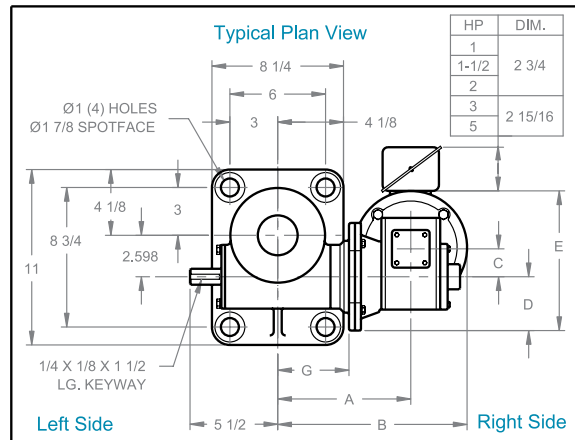
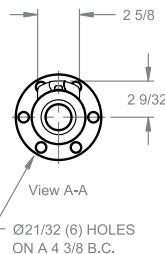
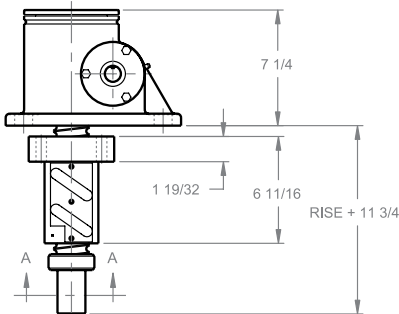

Inverted

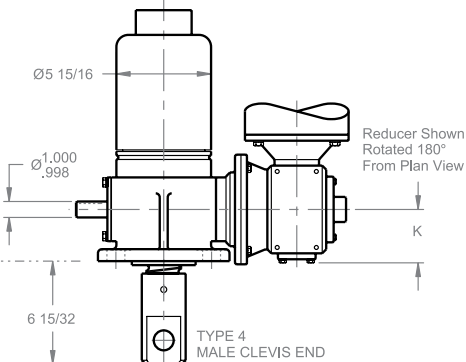
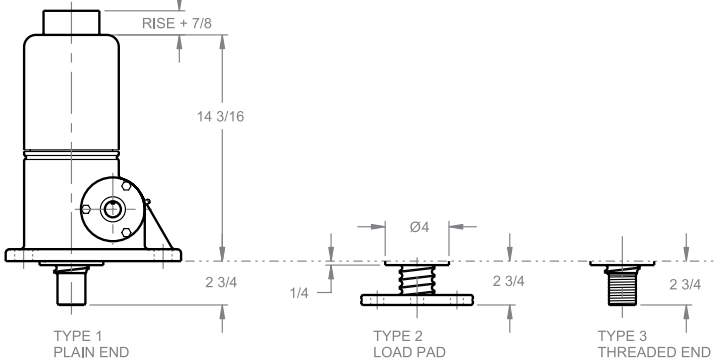

NOTE: FOR LIFTING CAPACITIES SEE PAGE 107.

Note: Drawings are artist's conception — not for certification; dimensions are subject to change without notice.

# BALL SCREW ComDRIVES®

## 30 TON - 3" SCREW STANDARD

CDB 1130  
CDB 3230

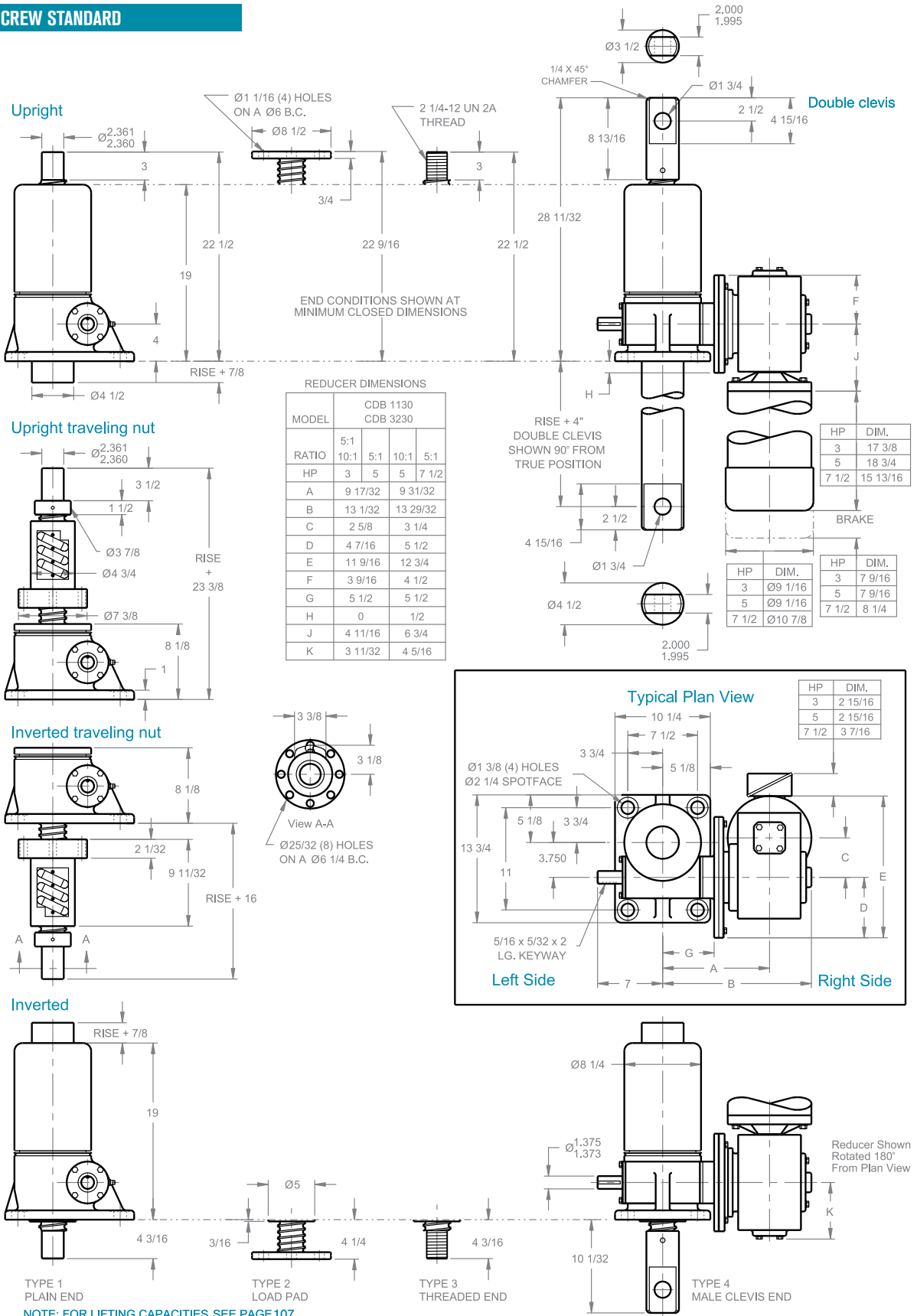

Note: Drawings are artist's conception — not for certification; dimensions are subject to change without notice.

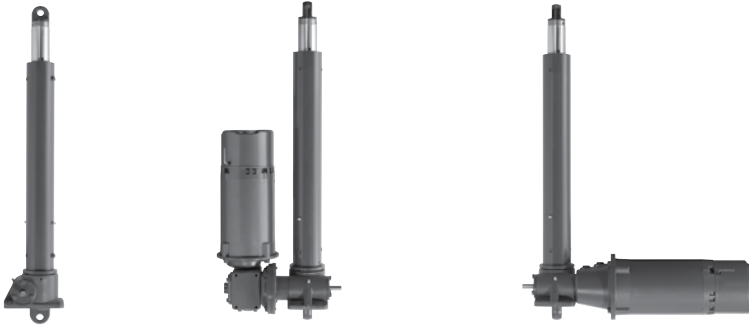

Joyce electric cylinders are designed to lift and precisely position loads in industrial environments where protection of the lifting screw mechanism is critical and low maintenance is desired. Requiring only electric power, Joyce electric cylinders may also be used in place of hydraulic cylinders, eliminating the cost and potential for leaks associated with hydraulic systems.

Electric cylinders use the same drive housings offered on our rugged machine screw and ball screw jacks. They are available in 2.5-ton to 20-ton capacities. Electric cylinders can achieve speeds up to 546 inches per minute and raise loads up to 100 inches. Complete dynamic speed/load ratings and maximum rise information can be viewed on our quick reference charts (pages 125 to 129). Both acme screw (ECA) and ball screw (ECB) models are designed to operate at the charted capacities under both tension and compression loading.

**Joyce Electric Cylinder Features and Benefits:**

- Ground and hard-chrome plated inner cylinder tube resists harsh contaminants while providing smooth cylinder translation.
- Dual lip tube seals retain lubrication while preventing dirt and grime from entering the internal cavity and contaminating the lifting screw.
- Enamel outer finish provides a durable coating for external surfaces.
- Rigid cylinder tube guide bearings provide resistance to buckling (external guides are required when side loads are present).
- Alloy steel input shafts riding on tapered roller bearings provide proper wormgear alignment for increased service life.
- Spring-loaded input shaft seals prevent the loss of lubrication.

Joyce can customize electric cylinders to meet your specifications.



# ELECTRIC CYLINDERS

## Electric Cylinder Operation:

The input shaft (worm) shaft rotates a wormgear, which in turn rotates the lifting screw. As the lifting screw rotates, it forces the lifting nut (fixed to the cylinder tube) to translate, thus extending or retracting the cylinder tube. For proper operation, the load being lifted must be restrained from rotation.

Joyce offers Electric Cylinders in several models including:

- Standard
- Motor mount
- ComDRIVE®

A guide for ordering is on pages 120 and 121.

# ELECTRIC CYLINDERS ORDERING INFORMATION

Instructions: Select a model number from this chart.

2.5-Ton ACME Screw	2.5-Ton Ball Screw	3-Ton ACME Screw	3-Ton Ball Screw	5-Ton ACME Screw	5-Ton Ball Screw	10-Ton ACME Screw	10-Ton Ball Screw	20-Ton ACME Screw	20-Ton Ball Screw
ECAL242.5	ECBL62.5 ECBL122.5 ECBL242.5	ECAL63 ECAL123 ECAL243	ECBL63 ECBL123 ECBL243	ECAL65 ECAL245	ECBL65 ECBL125 ECBL245	ECAL810 ECAL2410	ECBL810 ECBL2410	ECAL820 ECAL2420	ECBL820 ECBL2420
ECAH62.5 ECAH122.5 ECAH242.5	ECBM62.5  ECBH62.5		ECBH63 ECBH123 ECBH243	ECAM65 ECAM125 ECAM245	ECBM65 ECBM125 ECBM245	ECAM810 ECAM2410	ECBM810 ECBM2410	ECAM820 ECAM2420	
				ECAH65 ECAH125 ECAH245	ECBH65 ECBH125 ECBH245	ECAH810 ECAH2410	ECBH810 ECBH2410	ECAH820 ECAH2420	

**Important Note:** Electric Cylinders that are  $\geq 30\%$  efficient may lower under load. Brake motors or external locking systems are required. Detailed information about each electric cylinder model is available on pages 125-134.

Sample Part Number: **ECAL654C-18.5-STDX-STDX-X**

### Tube End Conditions



**3**  
(threaded end)



**4**  
(male clevis)



**5**  
(female clevis)



**6**  
(female clevis with pin)

### Cylinder Rise

Rise is travel expressed in inches and not the actual tube length.

The allowable travel for each unit is listed in the Quick Reference section.

Allowable lengths differ for vertical and horizontal mounting.

### Left Side Shaft Code

(see below)



**XXXX**=Remove  
**STDX**=Standard  
**CUST**=Custom

For optional shaft codes, see page 121.

### Right Side Shaft Code

(see below)



**XXXX**=Remove  
**STDX**=Standard  
**CUST**=Custom

For optional shaft codes, see page 121.

### Additional Options\*

**X**=Standard, no additional options

**S**=Additional Specification Required (comment as necessary)

**Finishes p. 182**  
**F1**=Do Not Paint  
**F2**=Epoxy Paint  
**F3**=Outdoor Paint Process

**Motor Options**  
**M1**=Less Motor  
**M2**=Brake Motor  
**M3**=Single Phase Motor (120VAC)  
**M4**=50Hz Motor  
**M5**=Special Motor

**Grease/Seals**  
**H1**=High Temperature Operation  
**H2**=Food Grade Grease

\* Specify as many options as needed

### Base Designs



**F**=Flange Base



**C**=Clevis Base

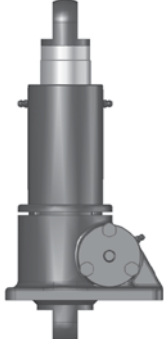

**R**=Rotated Clevis Base



# ELECTRIC CYLINDERS SHAFT CODES

**Instructions:** Select the appropriate shaft codes for both right and left hand shafts. One shaft code must be specified for each side of the electric cylinder.

## Mechanical Counters (p. 180)

**CNT0**=0.001" Increments

Note: Contact Joyce for availability and options.



## Hand Wheels (p. 180)

- HW04**=4" dia
- HW06**=6" dia
- HW08**=8" dia
- HW10**=10" dia
- HW12**=12" dia



Not recommended for electric cylinders that are ≥ 30% efficient.

## Geared Potentiometers (p. 175)

- POTA**=0-10V
- POTB**=4-20mA
- POTC**=0-10V w/2 switches
- POTD**=4-20mA w/2 switches
- IP65 rated enclosures



## Encoders (pp. 176-177)

- ENCA**=Absolute Encoder 0-10 VDC, programmable
- ENCB**=Absolute Encoder 4-20mA, programmable
- ENCC**=Absolute Encoder CAN Open
- ENCD**=Absolute Encoder SSI
- ENCS**=Stainless Steel Incremental Encoder 1024 PPR
- ENCX**=Incremental Encoder 200 PPR
- ENCY**=Incremental Encoder 1024 PPR



## ComDRIVE Reducers (pp. 125-134)

Ordering Example: **P2AC** — Motor code from chart at right

### Mounting Positions

Code	P1	P2	P3	P4	Ratio
Left Side Shaft Positions					5:1 Code A
					7.5:1 Code B
					10:1 Code C
Right Side Shaft Positions					15:1 Code D
					Special Ratio Code X

## Motors

Size	Code
1/4 HP	K
1/3 HP	A
1/2 HP	B
3/4 HP	C
1 HP	D
1-1/2 HP	E
2 HP	F
3 HP	L
5 HP	G

## Motor Mounts (pp. 178-179)

Ordering Example:

**MMA A**



- MMA**=56C
  - MMB**=140TC
  - MMC**=180TC
  - MMD**=210TC
- Motor code from chart at left  
For servo motor mounts see p. 178

Standard motor adapters are aluminum.

All standard motors are 3-phase, 208-230/460 VAC or 230/460 VAC. Specify the appropriate motor size from the chart above. Refer to the "Additional Options" chart on the preceding page as needed. Brake motors are required for electric cylinders that are more than 30% efficient. Contact Joyce for options that are not listed.

## Mechanical Limit Switches (p. 174)

Ordering Example: **LA13**

Models		Number of DPDT Switches (see p. 174)	Available Positions			
Model	Code		1	3	5	
LS7-402	LI	NOTE: Will always be 0 for LS7 models	Left Side Shaft Options			
LS8-402	LA			Right Side Shaft Options		
LS8-404	LB		• 2.5, 3, 5, 10, and 20 Ton Electric Cylinders are available with positions #1, #3, and #5			

To order additional options, use these part numbers (p. 124)

- Female Clevis Bracket
- FCB-30
- FCB-100
- FCB-200
- Clevis Pin w/ retaining rings
- CP-30
- CP-100
- CP-200
- Female Rod Clevis
- FRC-30
- FRC-100
- FRC-200

# ELECTRIC CYLINDERS MODELS



## Standard

The Joyce standard electric cylinder is intended for applications where the customer provides their own drive mechanism. To determine capacity, input torque, and turns-per-inch use the specification chart on page 123. This design can also be used where one or more electric cylinders are being driven by one common drive motor or in combination with the motor mount (direct drive) or ComDRIVE® models listed below.

### Example part number:

**ECAL635C-15.00-STDX-HW08-X**

Acme screw (ECA), low lead (L), 6:1 gear ratio (6), 3-ton capacity (3), female clevis (5), clevis base (C), 15 inches rise (15), standard input shaft left hand side of jack (STDX), 8" diameter hand wheel right side of jack (HW08), no additional options (X).



## Motor Mount (direct drive)

Joyce motor mount electric cylinders are intended for higher speed applications. Motor mount models can be used in conjunction with one or more of the standard electric cylinders shown above. To determine lifting speed and capacity, view "direct drive" models shown on the quick reference charts (pages 125-129). Standard motors are 3-phase, 230/460 VAC, 60 Hz, and 1750 RPM. For additional motor information, see page 179.

### Example part number:

**ECAM24104R-9.50-STDX-MMBE-F2**

Acme screw (ECA), medium lead (M), 24:1 gear ratio (24), 10-ton capacity (10), male clevis (4), rotated clevis base (R), 9 1/2 inches rise (9.50), standard input shaft left hand side of jack (STDX), 145TC motor mount (MMB) with 1 1/2 HP motor (E) on right hand side, epoxy paint (F2).



## ComDRIVE®

Joyce ComDRIVE® models include a right angle gearmotor mounted to the right or left side of the standard model. ComDRIVES are intended for applications requiring heavy lifting capacities at speeds up to 34 inches per minute (acme screw) and 104 inches per minute (ball screw). ComDRIVE models can be used in conjunction with one or more of the standard electric cylinders shown above. To determine lifting speeds and capacity, refer to the charts on pages 125-129.

### Example part number:

**ECAH8206F-52.25-P1CL-ENCX-M3**

Acme screw (ECA), high lead (H), 8:1 gear ratio (8), 20-ton capacity (20), female clevis with pin (6), flange base (F), 52 1/4 inches rise (52.25), 10:1 reducer with a 3 horsepower motor mounted to left hand side of jack (P1CL), encoder on right side of jack (ENCX), single phase motor (M3).

# ELECTRIC CYLINDERS SPECIFICATIONS

Model	Static Capacity	Screw Diameter	Thread Pitch/Lead	Wormgear Ratio	Worm Shaft Turns for 1" Travel	Tare Torque (Inch Lbs.)	Starting Torque (Inch Lbs.)	Operating Torque (Inch Lbs.)	Translating Tube Torque (Inch Lbs.)	Base Weight	Weight per Inch Travel					
ECAL242.5	2.5 ton	1	.25 pitch ACME 2C	24:1	96	6	.018W*	.010W* @500 RPM	.098W*	24	1.5					
ECAH62.5				6:1	12	8	.056W*	.040W* @500 RPM								
ECAH122.5			.25 pitch .5 lead ACME 2C	12:1	24	7	.035W*	.023W* @500 RPM	.140W*							
ECAH242.5				24:1	48	6	.025W*	.014W* @500 RPM								
ECBL62.5			0.25 lead ball	6:1	24	8	.017W*	.013W* @500 RPM	.045W*	30	1.5					
ECBL122.5				12:1	48	7	.010W*	.008W* @500 RPM								
ECBL242.5				24:1	96	6	.008W*	.005W* @500 RPM								
ECBM62.5				.5 lead ball	6:1	12	8	.033W*				.026W* @500 RPM	.089W*			
ECBH62.5					1.0 lead ball	6:1	6	8				.065W*		.051W* @500 RPM	.177W*	
ECAL63				3 ton	1 1/4	.25 pitch ACME 2C	6:1	24				9	.048W*	.033W* @500 RPM	.114W*	26
ECAL123	12:1	48	8				.030W*	.018W* @500 RPM								
ECAL243	24:1	96	7				.021W*	.011W* @500 RPM								
ECBL63	1 3/20	.2 lead ball	6:1				30	9	.013W*	.011W* @500 RPM	.036W*	32	1.9			
ECBL123			12:1				60	8	.008W*	.006W* @500 RPM						
ECBL243			24:1		120	7	.006W*	.004W* @500 RPM								
ECBH63	1 1/16	.625 lead ball	6:1		9.6	9	.041W*	.032W* @500 RPM	.111W*	1.8						
ECBH123			12:1		19.2	8	.025W*	.018W* @500 RPM								
ECBH243			24:1		38.4	7	.018W*	.011W* @500 RPM								
ECAL65			5 ton		1 1/2	.25 pitch ACME 2C	6:1	24			15	.057W*	.039W* @300 RPM	.130W*	50	2.3
ECAL245				24:1			96	12			.026W*	.014W* @300 RPM				
ECAM65	.375 pitch STUB ACME	6:1		16			15	.065W*	.045W* @300 RPM	.151W*						
ECAM125		12:1		32			13	.041W*	.025W* @300 RPM							
ECAM245		24:1		64		12	.030W*	.016W* @300 RPM								
ECAH65		.25 pitch .5 lead ACME 2C		6:1		12	15	.073W*	.051W* @300 RPM		.171W*					
ECAH125	12:1			24		13	.046W*	.029W* @300 RPM								
ECAH245	24:1			48		12	.033W*	.018W* @300 RPM								
ECBL65	.474 lead ball			6:1		12.66	15	.032W*	.025W* @300 RPM	.084W*						
ECBL125		12:1		25.33		13	.020W*	.014W* @300 RPM								
ECBL245		24:1		50.66		12	.015W*	.009W* @300 RPM								
ECBM65		1.0 lead ball		6:1		6	15	.067W*	.052W* @300 RPM		.177W*					
ECBM125	12:1			12		13	.042W*	.030W* @300 RPM								
ECBM245	24:1			24		12	.031W*	.018W* @300 RPM								
ECBH65	1.875 lead ball			6:1		3.2	15	.125W*	.098W* @300 RPM	.332W*						
ECBH125		12:1		6.4		13	.079W*	.055W* @300 RPM								
ECBH245		24:1		12.8		12	.057W*	.034W* @300 RPM								
ECAL810		10 ton		2		.25 pitch ACME 2C	8:1	32	30		.052W*	.036W* @200 RPM	.162W*	64	2.8	
ECAL2410	24:1						96	25	.026W*	.016W* @200 RPM						
ECAM810	.5 pitch ACME 2C						8:1	16	30	.061W*	.044W* @200 RPM	.195W*				
ECAM2410			24:1		48	25	.031W*	.019W* @200 RPM								
ECAH810			.333 pitch .666 lead ACME 2C		8:1	12	30	.070W*	.051W* @200 RPM	.228W*						
ECAH2410					24:1	36	25	.035W*	.022W* @200 RPM							
ECBL810	1 1/2		.474 lead ball		8:1	16.88	30	.023W*	.019W* @200 RPM	.084W*	81	2.3				
ECBL2410				24:1	50.66	25	.012W*	.008W* @200 RPM								
ECBM810				1.0 lead ball	8:1	8	30	.049W*	.040W* @200 RPM				.172W*			
ECBM2410			24:1		24	25	.024W*	.017W* @200 RPM								
ECBH810			1.875 lead ball		8:1	4.27	30	.091W*	.074W* @200 RPM	.332W*						
ECBH2410					24:1	12.8	25	.045W*	.031W* @200 RPM							
ECAL820			20 ton	2 1/2	.25 pitch ACME 2C	8:1	32	60	.066W*	.044W* @200 RPM			.194W*	124	4.9	
ECAL2420	24:1					96	40	.035W*	.019W* @200 RPM							
ECAM820	.5 pitch ACME 2C	8:1			16	60	.075W*	.052W* @200 RPM	.227W*							
ECAM2420		24:1			48	40	.039W*	.022W* @200 RPM								
ECAH820		.375 pitch .75 lead ACME 2C			8:1	10.67	60	.088W*		.062W* @200 RPM	.273W*					
ECAH2420	24:1			32	40	.046W*	.027W* @200 RPM									
ECBL820	2 1/4	.5 lead ball		8:1	16	60	.026W*	.020W* @200 RPM	.089W*	164	4.5					
ECBL2420				24:1	48	40	.014W*	.009W* @200 RPM								

**Important Note:** Electric cylinders that are ≥ 30% are not self-locking. Brake motors or external locking systems are required.

\*W: Load in pounds.

**Tare Torque:** Initial torque to overcome seal and normal assembly drag. This value must be added to starting torque or operating torque values.

**Starting Torque:** Torque value required to start moving a given load (dissipates to operating torque values once the load begins moving).

**Operating Torque:** Torque required to continuously raise a given load at the input RPM listed.

**Translating Tube Torque:** Torque required to resist tube rotation.

**Lead:** The distance traveled axially in one rotation of the lifting screw.

**Pitch:** The distance from a point on a screw thread to a corresponding point on the next thread, measured axially.

**Note:** This chart is provided for reference only. For specific information such as allowable continuous travel or ball nut life and other performance factors refer to JAX® Online software or contact Joyce.

# ELECTRIC CYLINDERS CLEVIS AND BRACKET

## Female Rod Clevis

A female rod clevis end is included for type 5 and type 6 end conditions. They are also available as options.

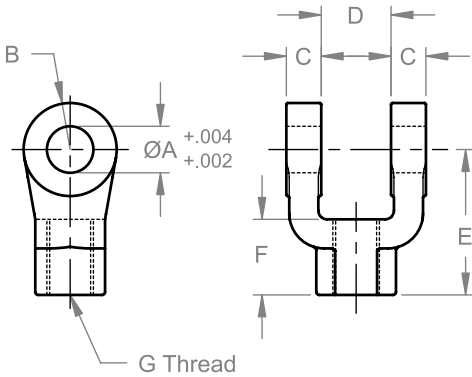

Cylinder Capacity	Part Number	Dimensions (Inches)							Load Capacity (Lbs.)
		ØA	B	C	D	E	F	G	
2.5 & 3	FRC-30	3/4	3/4	5/8	1 1/4	2 3/8	1 1/8	3/4-16	11,200
5 & 10	FRC-100	1	1	3/4	1 1/2	3 1/8	1 5/8	1-14	19,500
20	FRC-200	1 3/8	1 3/8	1	2	4 1/8	2	1 1/4-12	33,500

## Clevis Pin with Retaining Rings

A clevis pin with retaining rings is included on type 6 end conditions. They are also available as options.

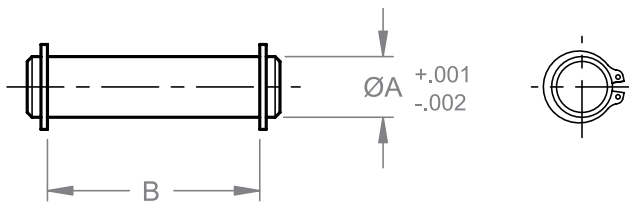

Cylinder Capacity	Part Number	Dimensions (Inches)		Load Capacity (Lbs.)
		ØA	B	
2.5 & 3	CP-30	3/4	2 5/8	19,300
5 & 10	CP-100	1	3 1/8	34,300
20	CP-200	1 3/8	4 1/8	65,000

## Female Clevis Bracket

Female clevis brackets are available as options.

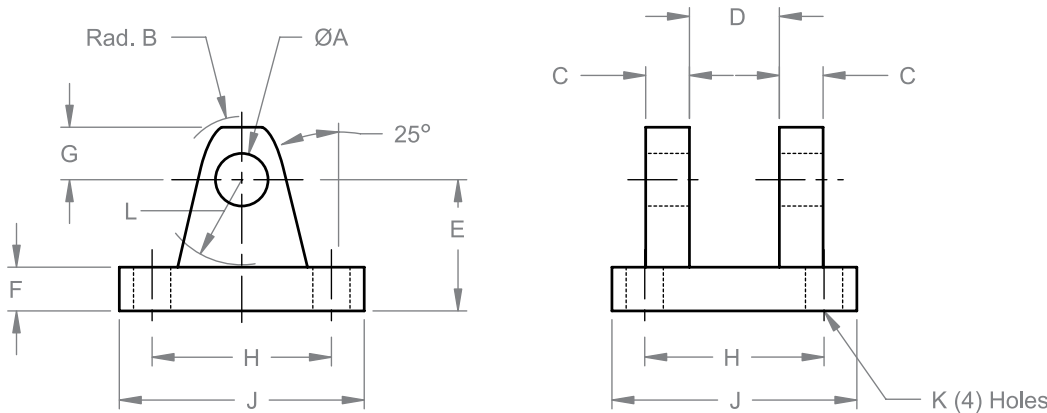

Cylinder Capacity	Part Number	Dimensions (Inches)											Load Capacity (Lbs.)
		ØA	B	C	D	E	F	G	H	J	K	L	
2.5 & 3	FCB-30	3/4	29/32	5/8	1 1/4	1 7/8	5/8	3/4	3.82	5	17/32	1 3/16	14,000
5 & 10	FCB-100	1	1 1/4	3/4	1 1/2	2 1/4	3/4	1	4.95	6 1/2	21/32	1 1/2	19,200
20	FCB-200	1 3/8	1 21/32	1	2	3	7/8	1 3/8	5.73	7 1/2	21/32	2	33,500

Note: Drawings are artist's conception — not for certification; dimensions are subject to change without notice.

# ELECTRIC CYLINDERS QUICK REFERENCE

Use the following charts to select the electric cylinder that best fits your application. Refer to drawings on page 130. Contact Joyce with questions regarding the proper selection of electric cylinders.

2.5-Ton Thrust Capacity Electric Cylinders											
Model	Max Static Capacity (tons)	Screw Lead (in)	Linear Speed (in/min)	External Gearbox Ratio	Estimated Efficiency	Max Dynamic Load at HP (lbs)					
						.33HP	.5HP	.75HP	1HP	1.5HP	2HP
<b>ACME Screw</b>											
ECAL242.5	2.5	0.250	1.76	10	14%	5,000					
ECAL242.5	2.5	0.250	2.38	7.5	15%	5,000					
ECAH242.5	2.5	0.500	3.53	10	20%	5,000					
ECAH242.5	2.5	0.500	4.76	7.5	21%	5,000					
ECAH122.5	2.5	0.500	7.06	10	25%	4,234	5,000				
ECAH122.5	2.5	0.500	9.52	7.5	26%	3,219	5,000				
ECAH62.5	2.5	0.500	14.12	10	28%	2,374	3,701	5,000			
ECAL242.5	2.5	0.250	18.23	Direct drive	21%	756	1,543				
ECAH62.5	2.5	0.500	19.04	7.5	29%	1,787	2,811	4,317			
ECAH62.5	2.5	0.500	27.78	5	30%	1,213	1,946	3,025			
ECAH242.5	2.5	0.500	36.46	Direct drive	30%	525	1,072				
ECAH122.5	2.5	0.500	72.92	Direct drive	33%		555	1,010	1,464	2,373	
ECAH62.5	2.5	0.500	145.83	Direct drive	36%			512	754	1,238	1,723
<b>Ball Screw</b>											
ECBL242.5	2.5	0.250	1.76	10	30%	5,000					
ECBL242.5	2.5	0.250	2.38	7.5	32%	5,000					
ECBL122.5	2.5	0.250	3.53	10	38%	5,000					
ECBL122.5	2.5	0.250	4.76	7.5	40%	5,000					
ECBL62.5	2.5	0.250	7.06	10	43%	5,000					
ECBL62.5	2.5	0.250	9.52	7.5	45%	5,000					
ECBL62.5	2.5	0.250	13.89	5	47%	3,752	5,000				
ECBL242.5	2.5	0.250	18.23	Direct drive	46%	1,624	3,315				
ECBM62.5	2.5	0.500	19.04	7.5	45%	2,763	4,347	5,000			
ECBM62.5	2.5	0.500	27.78	5	47%	1,876	3,010	4,678	5,000		
ECBL122.5	2.5	0.250	36.46	Direct drive	52%	762	1,718	3,123	4,528	5,000	
ECBH62.5	2.5	1.000	38.08	7.5	45%	1,381	2,173	3,338			
ECBH62.5	2.5	1.000	55.56	5	47%	938	1,505	2,339	3,247		
ECBL62.5	2.5	0.250	72.92	Direct drive	55%		833	1,582	2,331	3,830	5,000
ECBM62.5	2.5	0.500	145.83	Direct drive	55%			791	1,166	1,915	2,664
ECBH62.5	2.5	1.000	291.67	Direct drive	55%				583	957	1,332

2.5-Ton Electric Cylinders			
	Maximum Rise		Cylinder Tube Torque
	Vertical Operation	Horizontal Operation	(in*lb) Per Pound Thrust
<b>ACME Screw</b>			
ECAL	28"	21"	.098
ECAH	28"	21"	.139
<b>Ball Screw</b>			
ECBL	41"	31"	.045
ECBM	44"	33"	.089
ECBH	41"	31"	.178

## Selection Guidelines:

- Select the model most closely matching your desired load and speed requirements. The chart is sorted by static capacity, then screw type (ACME or ball), then travel speed.
- To determine the maximum rise for the model selected, see maximum rise chart above.
- L, M, and H in the model numbers designate low, medium, or high screw leads.
- ECA models are not suitable for duty cycles greater than 25%.
- All models with efficiencies >30% require a brake motor.**
- Models with efficiencies ≤30% are self-locking in the absence of vibration. A brake motor is required if vibration is present or faster stopping times are desired.
- Loads and speeds shown assume use of a 1750 rpm 3ph AC induction motor.
- Cylinder tube torque per pound thrust is the means to calculate how much torque must be resisted at the mounting locations of the cylinder. To calculate torque (in\*lb), multiply the value in the chart times the load in pounds.
- When ordering cylinders with a ComDRIVE reducer the listed part number should specify the proper 4 letter ComDRIVE shaft code from page 121. Units with a "direct drive" listing should specify the proper 4 letter motor mount code listed on page 121.
- Note: For normal operation, the translating tube end must be restrained from rotation.

# ELECTRIC CYLINDERS QUICK REFERENCE

Use the following charts to select the electric cylinder that best fits your application. Refer to drawings on page 131. Contact Joyce with questions regarding the proper selection of electric cylinders.

3-Ton Thrust Capacity Electric Cylinders											
Model	Max Static Capacity (tons)	Screw Lead (in)	Linear Speed (in/min)	External Gearbox Ratio	Estimated Efficiency	Max Dynamic Load at HP (lbs)					
						.33HP	.5HP	.75HP	1HP	1.5HP	2HP
<b>ACME Screw</b>											
ECAL243	3	0.250	1.76	10	12%	6,000					
ECAL243	3	0.250	2.38	7.5	13%	6,000					
ECAL123	3	0.250	3.53	10	15%	5,183	6,000				
ECAL123	3	0.250	4.76	7.5	16%	3,926	6,000				
ECAL63	3	0.250	7.06	10	17%	2,906	4,547	6,000			
ECAL63	3	0.250	9.52	7.5	18%	2,179	3,446	5,310			
ECAL63	3	0.250	13.89	5	19%	1,468	2,375	3,710	5,162		
ECAL243	3	0.250	18.23	Direct drive	18%		1,215				
ECAL63	3	0.250	72.92	Direct drive	22%				899	1,499	2,098
<b>Ball Screw</b>											
ECBL243	3	0.200	1.41	10	30%	6,000					
ECBL243	3	0.200	1.90	7.5	32%	6,000					
ECBL123	3	0.200	2.82	10	38%	6,000					
ECBL123	3	0.200	3.81	7.5	40%	6,000					
ECBH243	3	0.625	4.41	10	30%	6,000					
ECBL63	3	0.200	5.65	10	43%	6,000					
ECBH243	3	0.625	5.95	7.5	32%	6,000					
ECBL63	3	0.200	7.62	7.5	45%	6,000					
ECBH123	3	0.625	8.82	10	38%	5,183	6,000				
ECBL63	3	0.200	11.11	5	47%	4,587	6,000				
ECBH123	3	0.625	11.90	7.5	40%	3,926	6,000				
ECBL243	3	0.200	14.58	Direct drive	46%	1,686	3,798				
ECBH63	3	0.625	17.65	10	43%	2,906	4,547	6,000			
ECBH63	3	0.625	23.80	7.5	45%	2,179	3,446	5,310			
ECBL123	3	0.200	29.17	Direct drive	52%	758	1,952	3,709	5,465	6,000	
ECBH63	3	0.625	34.72	5	47%	1,468	2,375	3,710	5,162		
ECBH243	3	0.625	45.57	Direct drive	46%		1,215				
ECBL63	3	0.200	58.33	Direct drive	55%		937	1,874	2,810	4,683	6,000
ECBH123	3	0.625	91.15	Direct drive	52%		625	1,187	1,749	2,873	
ECBH63	3	0.625	182.29	Direct drive	55%				899	1,499	2,098

3-Ton Electric Cylinders			
	Maximum Rise		Cylinder Tube Torque
	Vertical Operation	Horizontal Operation	(in*lb) Per Pound Thrust
<b>ACME Screw</b>			
ECAL	48"	36"	.113
<b>Ball Screw</b>			
ECBL	56"	42"	.036
ECBH	46"	34"	.111

## Selection Guidelines:

- Select the model most closely matching your desired load and speed requirements. The charts are sorted by static capacity, then screw type (ACME or ball), then travel speed.
- To determine the maximum rise for the model selected, see maximum rise charts above and to the right.
- L, M, and H in the model numbers designate low, medium, or high screw leads.
- ECA models are not suitable for duty cycles greater than 25%.
- **All models with efficiencies >30% require a brake motor.**
- Models with efficiencies ≤30% are self-locking in the absence of vibration. A brake motor is required if vibration is present or faster stopping times are desired.
- Loads and speeds shown assume use of a 1750 rpm 3ph AC induction motor.
- Cylinder tube torque per pound thrust is the means to calculate how much torque must be resisted at the mounting locations of the cylinder. To calculate torque (in\*lb), multiply the value in the chart times the load in pounds.
- When ordering cylinders with a ComDRIVE the reducer listed in the part number should specify the proper ComDRIVE 4 letter shaft code from page 121. Units with a "direct drive" listing should specify the proper 4 letter motor mount code listed on page 121.
- Note: For normal operation, the translating tube end must be restrained from rotation.

# ELECTRIC CYLINDERS QUICK REFERENCE

Use the following charts to select the electric cylinder that best fits your application. Refer to drawings on page 132. Contact Joyce with questions regarding the proper selection of electric cylinders.

5-Ton Thrust Capacity Electric Cylinders												
Model	Max Static Capacity (tons)	Screw Lead (in)	Linear Speed (in/min)	External Gearbox Ratio	Estimated Efficiency	Max Dynamic Load at HP (lbs)						
						.33HP	.5HP	.75HP	1HP	1.5HP	2HP	3HP
<b>ACME Screw</b>												
ECAL245	5	0.250	1.76	10	11%	6,895	10,000					
ECAM245	5	0.375	2.65	10	14%	5,891	9,330	10,000				
ECAH245	5	0.500	3.53	10	16%	5,193	8,224	10,000				
ECAM125	5	0.375	5.29	10	17%	3,661	5,822	9,000	10,000			
ECAH125	5	0.500	7.06	10	20%	3,227	5,132	7,933	10,000			
ECAM65	5	0.375	10.59	10	19%	2,031	3,257	5,059	7,022			
ECAH65	5	0.500	14.12	10	23%	1,790	2,871	4,460	6,189			
ECAL245	5	0.250	18.23	Direct drive	16%			1,471				
ECAM65	5	0.375	20.83	5	21%		1,634	2,635	3,723	5,768	7,813	
ECAM245	5	0.375	27.34	Direct drive	21%			1,257				
ECAH65	5	0.500	27.78	5	25%		1,441	2,322	3,282	5,085	6,887	
ECAH245	5	0.500	36.46	Direct drive	24%			1,108				
ECAM125	5	0.375	54.69	Direct drive	23%				1,085	1,935		
ECAL65	5	0.250	72.92	Direct drive	19%					1,144	1,672	2,728
ECAM65	5	0.375	109.38	Direct drive	25%						1,429	2,331
ECAH65	5	0.500	145.83	Direct drive	29%						1,259	2,055
<b>Ball Screw</b>												
ECBL245	5	0.474	3.34	10	30%	10,000						
ECBL125	5	0.474	6.69	10	38%	6,441	10,000					
ECBM245	5	1.000	7.06	10	30%	4,910	7,775	10,000				
ECBH245	5	1.875	13.24	10	30%	2,618	4,147	6,394				
ECBL65	5	0.474	13.37	10	43%	3,572	5,729	8,900	10,000			
ECBM125	5	1.000	14.12	10	38%	3,051	4,852	7,500	10,000			
ECBH125	5	1.875	26.47	10	38%	1,627	2,588	4,000	5,537			
ECBL65	5	0.474	26.32	5	47%	1,678	2,875	4,635	6,550	10,000		
ECBM65	5	1.000	28.23	10	43%	1,692	2,714	4,216	5,851			
ECBL245	5	0.474	34.54	Direct drive	46%			2,211				
ECBH65	5	1.875	52.94	10	43%		1,447	2,249	3,121			
ECBM65	5	1.000	55.56	5	47%		1,362	2,196	3,103	4,807	6,511	
ECBL125	5	0.474	69.08	Direct drive	52%			1,162	1,910	3,404	4,898	
ECBM245	5	1.000	72.92	Direct drive	46%			1,048				
ECBH65	5	1.875	104.17	5	47%			1,171	1,655	2,564	3,473	
ECBL65	5	0.474	138.16	Direct drive	55%					1,720	2,513	4,101
ECBM125	5	1.000	145.83	Direct drive	52%					1,612	2,320	
ECBH125	5	1.875	273.44	Direct drive	52%						1,237	
ECBM65	5	1.000	291.67	Direct drive	55%						1,191	1,942
ECBH65	5	1.875	546.88	Direct drive	55%							1,036

5-Ton Electric Cylinders			
	Maximum Rise		Cylinder Tube Torque (in*lb) Per Pound Thrust
	Vertical Operation	Horizontal Operation	
<b>ACME Screw</b>			
ECAL	59"	44"	.131
ECAM	63"	47"	.151
ECAH	59"	44"	.171
<b>Ball Screw</b>			
ECBL	54"	40"	.084
ECBM	54"	40"	.178
ECBH	59"	44"	.332

Note: For proper model selection refer to Selection Guidelines on page 126.

# ELECTRIC CYLINDERS QUICK REFERENCE

Use the following charts to select the electric cylinder that best fits your application. Refer to drawings on page 133. Contact Joyce with questions regarding the proper selection of electric cylinders.

10-Ton Thrust Capacity Electric Cylinders													
Model	Max Static Capacity (tons)	Screw Lead (in)	Linear Speed (in/min)	External Gearbox Ratio	Estimated Efficiency	Max Dynamic Load at HP (lbs)							
						.33HP	.5HP	.75HP	1HP	1.5HP	2HP	3HP	5HP
<b>ACME Screw</b>													
ECAL2410	10	0.250	1.76	10	10%	5,417	9,111	14,543	19,976				
ECAL2410	10	0.250	1.71	10	10%							20,000	
ECAM2410	10	0.500	3.53	10	16%	4,468	7,515	11,996	16,872				
ECAM2410	10	0.500	3.42	10	17%							20,000	
ECAH2410	10	0.666	4.70	10	18%	3,811	6,409	10,231	14,390				
ECAH2410	10	0.666	4.55	10	19%							20,000	
ECAL810	10	0.250	5.29	10	12%	2,134	3,689	5,977	8,468				
ECAL810	10	0.250	5.13	10	13%							20,000	
ECAM2410	10	0.500	6.94	5	18%		3,554	6,112	8,896	14,126	19,355		
ECAM2410	10	0.500	7.29	5	19%							20,000	
ECAH2410	10	0.666	9.25	5	20%		3,031	5,213	7,587	12,047	16,508		
ECAH2410	10	0.666	9.71	5	21%							20,000	
ECAM810	10	0.500	10.59	10	20%		3,043	4,930	6,984				
ECAM810	10	0.500	10.25	10	21%							20,000	
ECAH810	10	0.666	14.10	10	23%		2,595	4,205	5,957				
ECAH810	10	0.666	14.10	10	24%							20,000	
ECAL2410	10	0.250	18.23	Direct drive	14%					2,440			
ECAM810	10	0.500	20.83	5	22%			2,367	3,503	5,637	7,771		
ECAM810	10	0.500	21.88	5	23%							11,611	19,837
ECAH810	10	0.666	27.75	5	25%			2,019	2,988	4,808	6,628		
ECAH810	10	0.666	29.14	5	26%							9,903	16,919
ECAM2410	10	0.500	36.46	Direct drive	23%					2,012			
ECAL810	10	0.250	54.69	Direct drive	16%							2,461	4,732
ECAM810	10	0.500	109.38	Direct drive	26%							2,030	3,903
ECAH810	10	0.666	145.69	Direct drive	29%								3,329
<b>Ball Screw</b>													
ECBL2410	10	0.474	3.34	10	34%	10,130	17,038	20,000					
ECBL2410	10	0.474	6.58	5	39%	4,113	8,057	13,858	20,000				
ECBM2410	10	1.000	7.06	10	34%	4,798	8,071	12,883	18,121				
ECBM2410	10	1.000	6.83	10	36%							20,000	
ECBL810	10	0.474	10.03	10	43%	3,990	6,899	11,178	15,834				
ECBL810	10	0.474	9.71	10	46%							20,000	
ECBH2410	10	1.875	13.24	10	34%	2,559	4,304	6,871	9,664				
ECBM2410	10	1.000	13.89	5	39%		3,817	6,565	9,554	15,171	20,000		
ECBL810	10	0.474	19.74	5	47%		2,999	5,366	7,942	12,781	17,619		
ECBL810	10	0.474	19.11	5	50%							20,000	
ECBM810	10	1.000	21.18	10	43%		3,268	5,295	7,501				
ECBM810	10	1.000	20.50	10	46%							20,000	
ECBH2410	10	1.875	26.04	5	39%		2,036	3,501	5,096	8,091	11,086		
ECBL2410	10	0.474	34.54	Direct drive	49%					4,562			
ECBH810	10	1.875	39.71	10	43%			2,824	4,000				
ECBM810	10	1.000	41.67	5	47%			2,542	3,762	6,054	8,346		
ECBM810	10	1.000	43.75	5	49%							12,470	20,000
ECBM2410	10	1.000	72.92	Direct drive	49%					2,161			
ECBH810	10	1.875	78.13	5	47%				2,006	3,229	4,451		
ECBH810	10	1.875	82.03	5	49%							6,651	11,363
ECBL810	10	0.474	103.62	Direct drive	56%						2,478	4,602	8,849
ECBM810	10	1.000	218.75	Direct drive	56%							2,180	4,192
ECBH810	10	1.875	409.84	Direct drive	56%								2,236

10-Ton Electric Cylinders			
	Maximum Rise		Cylinder Tube Torque (in*lb) Per Pound Thrust
	Vertical Operation	Horizontal Operation	
<b>ACME Screw</b>			
ECAL	84"	63"	.161
ECAM	60"	45"	.195
ECAH	76"	57"	.228
<b>Ball Screw</b>			
ECBL	38"	28"	.084
ECBM	38"	28"	.178
ECBH	41"	31"	.332

Note: For proper model selection refer to Selection Guidelines on page 129.



# ELECTRIC CYLINDERS QUICK REFERENCE

Use the following charts to select the electric cylinder that best fits your application. Refer to drawings on page 134. Contact Joyce with questions regarding the proper selection of electric cylinders.

20-Ton Thrust Capacity Electric Cylinders														
Model	Max Static Capacity (tons)	Screw Lead (in)	Linear Speed (in/min)	External Gearbox Ratio	Estimated Efficiency	Max Dynamic Load at HP (lbs)								
						.33HP	.5HP	.75HP	1HP	1.5HP	2HP	3HP	5HP	
<b>ACME Screw</b>														
ECAL2420	20	0.250	1.76	10	8%		6,459	10,813	15,552					
ECAL2420	20	0.250	1.71	10	8%								40,000	
ECAM2420	20	0.500	3.53	10	13%		5,484	9,181	13,205					
ECAM2420	20	0.500	3.42	10	14%								40,000	
ECAH2420	20	0.750	5.29	10	16%		4,560	7,634	10,979					
ECAH2420	20	0.750	5.13	10	17%								38,366	
ECAM2420	20	0.500	6.94	5	15%			4,305	6,621	10,972	15,324			
ECAM2420	20	0.500	7.29	5	15%								23,176	39,948
ECAM820	20	0.500	10.59	10	17%				5,276					
ECAM820	20	0.500	10.25	10	18%								19,447	
ECAH820	20	0.750	15.38	10	22%				4,387					
ECAH820	20	0.750	14.89	10	23%								16,170	
ECAL2420	20	0.250	18.23	Direct drive	11%								4,701	9,678
ECAM820	20	0.500	20.83	5	19%					4,127	5,935			
ECAM820	20	0.500	21.88	5	19%								9,218	16,187
ECAH820	20	0.750	31.25	5	23%						4,935			
ECAH820	20	0.750	32.81	5	24%								7,665	13,459
<b>Ball Screw</b>														
ECBL2420	20	0.500	3.53	10	33%	7,425	13,710	22,953	33,012					
ECBL2420	20	0.500	3.42	10	35%								40,000	
ECBL2420	20	0.500	6.94	5	37%		5,442	10,763	16,553	27,431	38,309			
ECBL2420	20	0.500	7.29	5	39%								40,000	
ECBL820	20	0.500	10.59	10	43%		4,876	8,857	13,189					
ECBL820	20	0.500	10.25	10	45%								40,000	
ECBL820	20	0.500	20.83	5	47%				5,797	10,317	14,837			
ECBL820	20	0.500	21.88	5	48%								23,046	40,000
ECBL2420	20	0.500	36.46	Direct drive	49%						4,697			
ECBL820	20	0.500	109.38	Direct drive	55%									6,665

20-Ton Electric Cylinders			
	Maximum Rise		Cylinder Tube Torque (in*lb) Per Pound Thrust
	Vertical Operation	Horizontal Operation	
<b>ACME Screw</b>			
ECAL	100"	75"	.178
ECAM	78"	58"	.210
ECAH	88"	66"	.244
<b>Ball Screw</b>			
ECBL	72"	54"	.089

## Selection Guidelines:

- Select the model most closely matching your desired load and speed requirements. The charts are sorted by static capacity, then screw type (ACME or ball), then travel speed.
- To determine the maximum rise for the model selected, see maximum rise charts above and to the left.
- L, M, and H in the model numbers designate low, medium, or high screw leads.
- ECA models are not suitable for duty cycles greater than 25%.
- **All models with efficiencies >30% require a brake motor.**
- Models with efficiencies ≤30% are self-locking in the absence of vibration. A brake motor is required if vibration is present or faster stopping times are desired.
- Loads and speeds shown assume use of a 1750 rpm 3ph AC induction motor.
- Cylinder tube torque per pound thrust is the means to calculate how much torque must be resisted at the mounting locations of the cylinder. To calculate torque (in\*lb), multiply the value in the chart times the load in pounds.
- When ordering cylinders with a ComDRIVE the reducer listed in the part number should specify the proper 4 letter ComDRIVE shaft code from page 121. Units with a "direct drive" listing should specify the proper 4 letter motor mount code listed on page 121.
- Note: For normal operation, the translating tube end must be restrained from rotation.

# ELECTRIC CYLINDERS

## 2 1/2 TON ELECTRIC CYLINDER

ECA (ACME SCREW)  
ECB (BALL SCREW)

### STANDARD

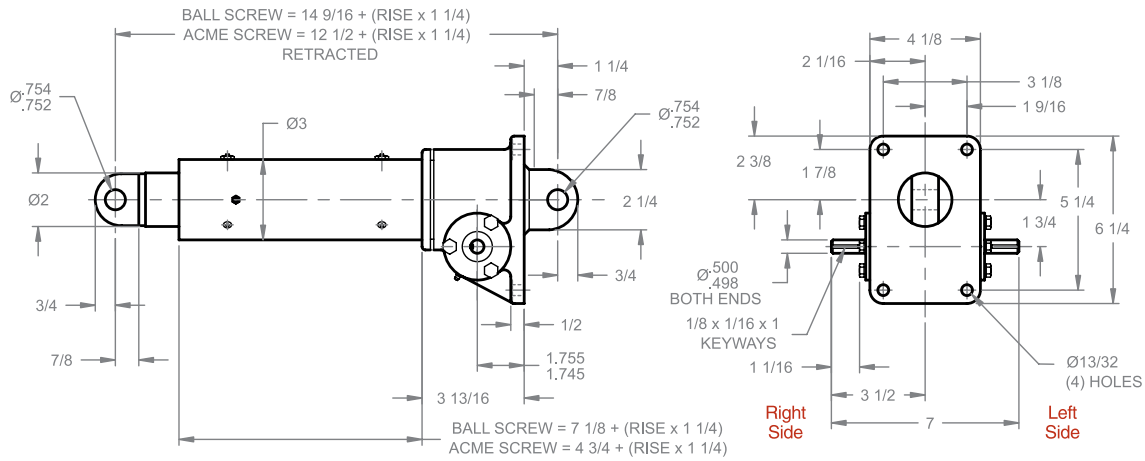

### MOTOR MOUNT

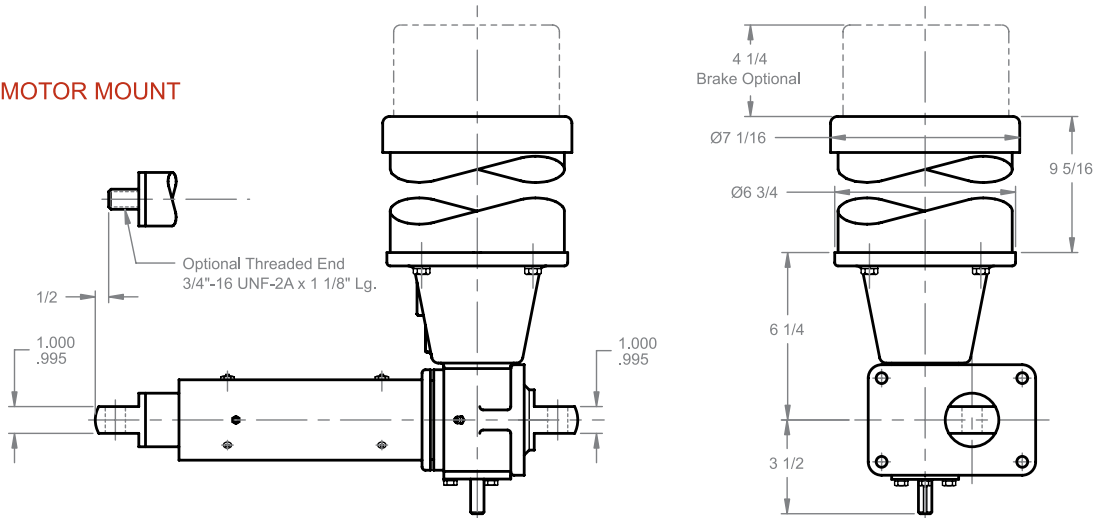

### ComDRIVE®

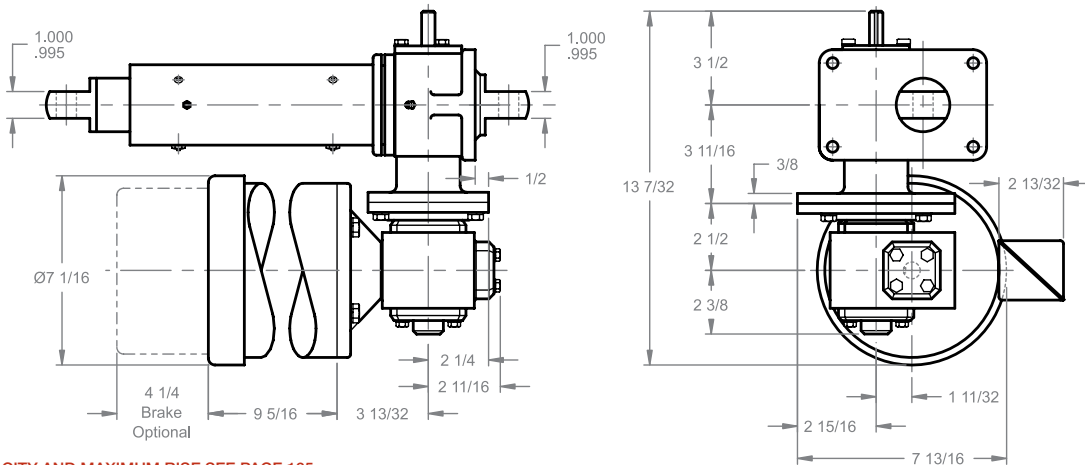

NOTE: FOR CAPACITY AND MAXIMUM RISE SEE PAGE 125.

Note: Drawings are artist's conception — not for certification; dimensions are subject to change without notice.

# ELECTRIC CYLINDERS

## 3 TON ELECTRIC CYLINDER

ECA (ACME SCREW)  
ECB (BALL SCREW)

### STANDARD

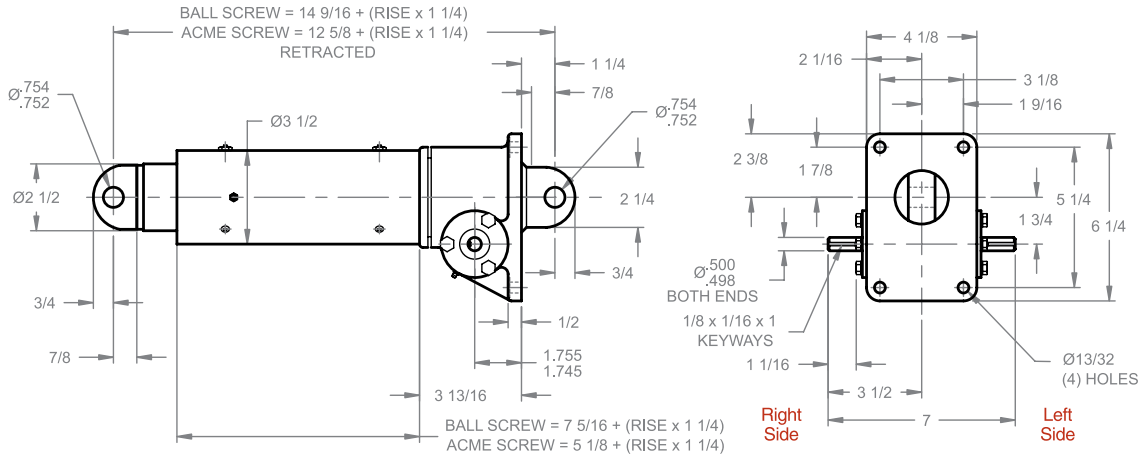

### MOTOR MOUNT

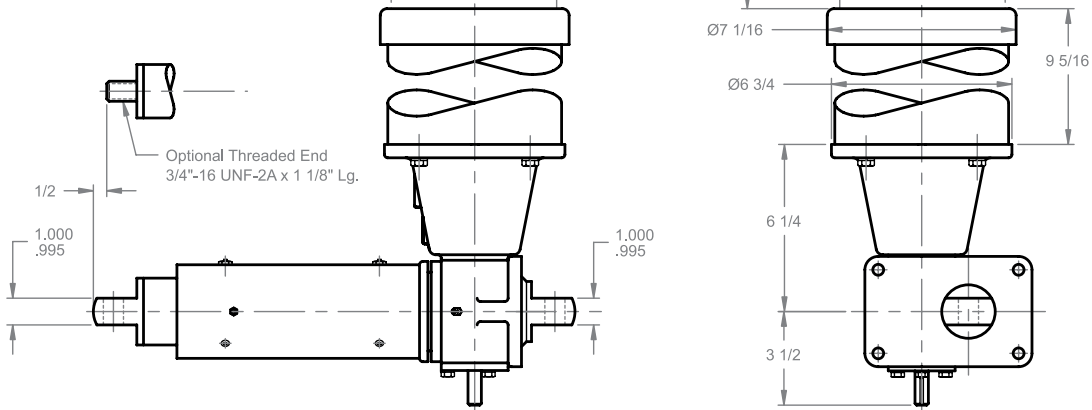

### ComDRIVE®

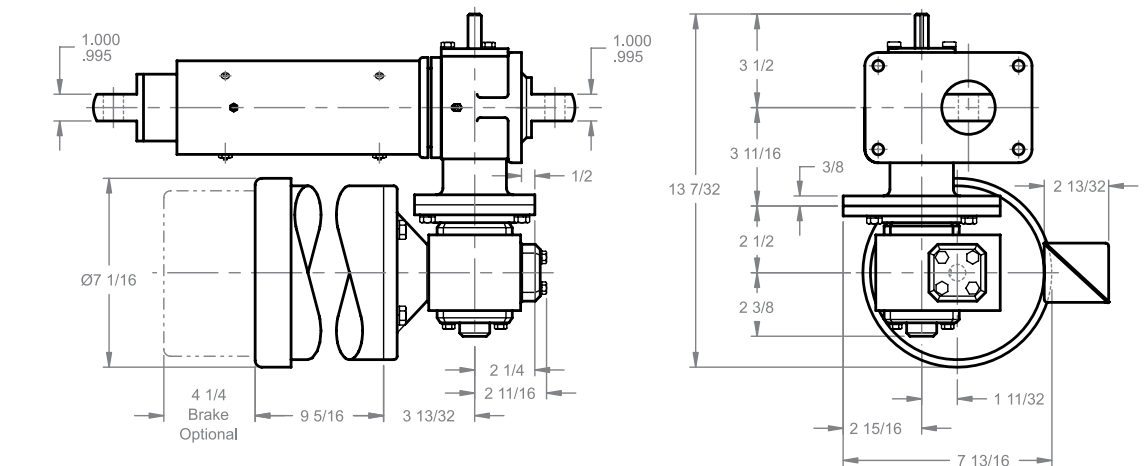

NOTE: FOR CAPACITY AND MAXIMUM RISE SEE PAGE 126.

Note: Drawings are artist's conception — not for certification; dimensions are subject to change without notice.

# ELECTRIC CYLINDERS

## 5 TON ELECTRIC CYLINDER

ECA (ACME SCREW)  
ECB (BALL SCREW)

### STANDARD

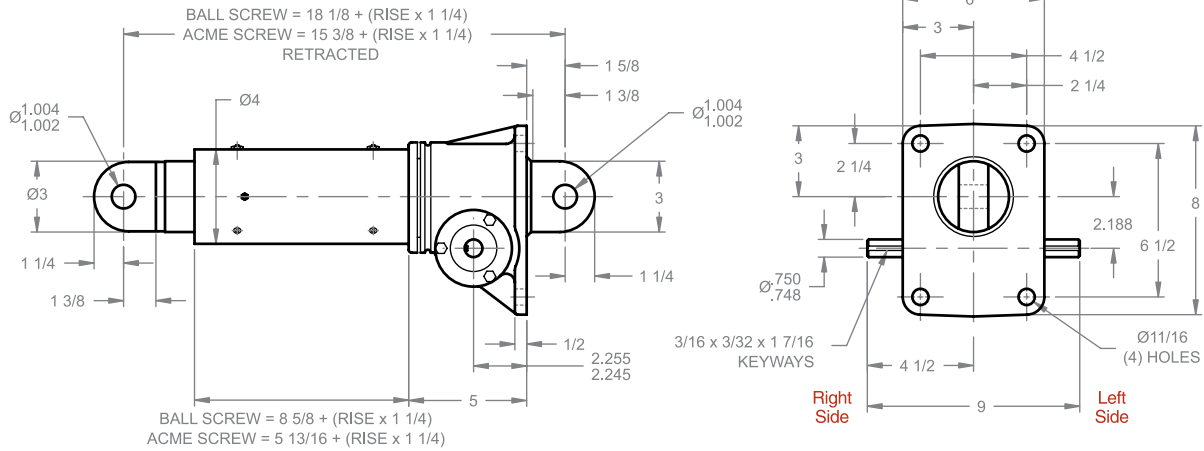

### MOTOR MOUNT

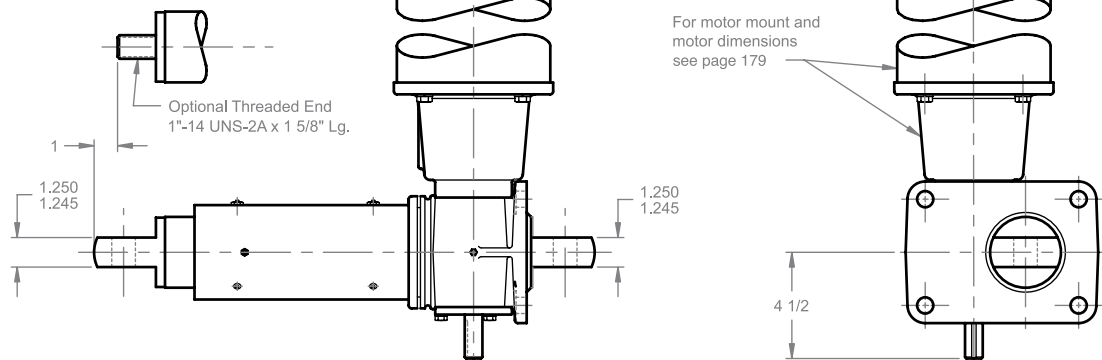

### ComDRIVE®

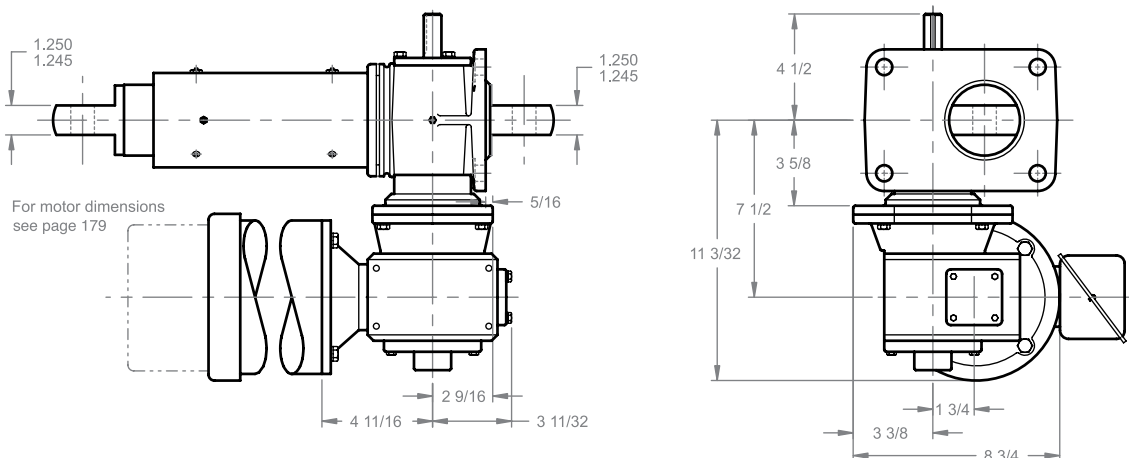

NOTE: FOR CAPACITY AND MAXIMUM RISE SEE PAGE 127.

Note: Drawings are artist's conception — not for certification; dimensions are subject to change without notice.

# ELECTRIC CYLINDERS

## 10 TON ELECTRIC CYLINDER

ECA (ACME SCREW)  
ECB (BALL SCREW)

### STANDARD

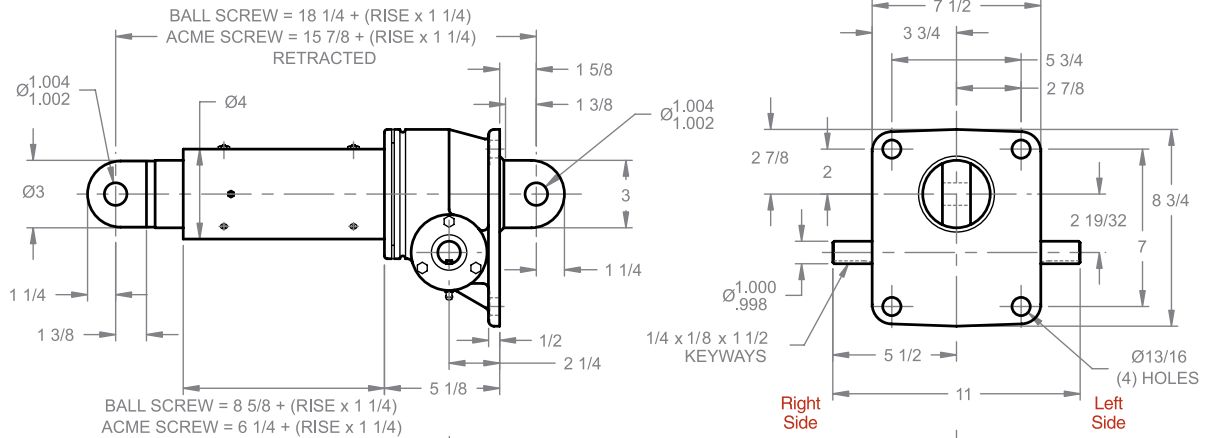

### MOTOR MOUNT

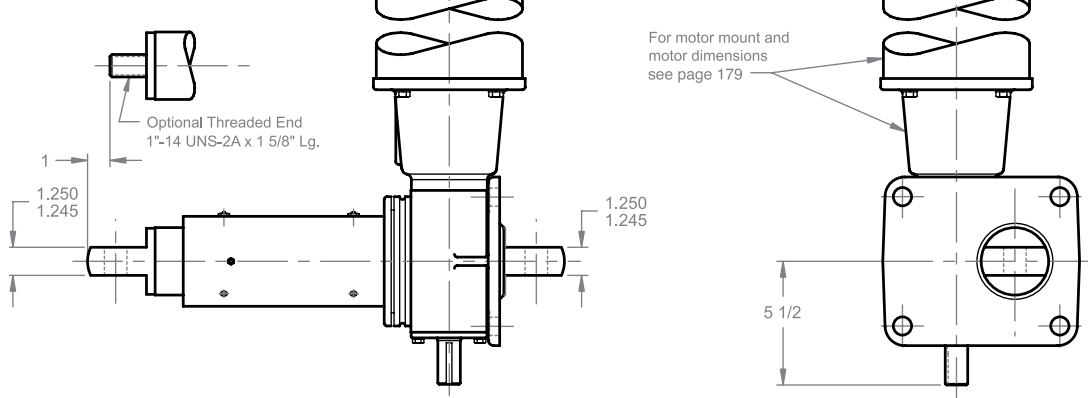

### ComDRIVE®

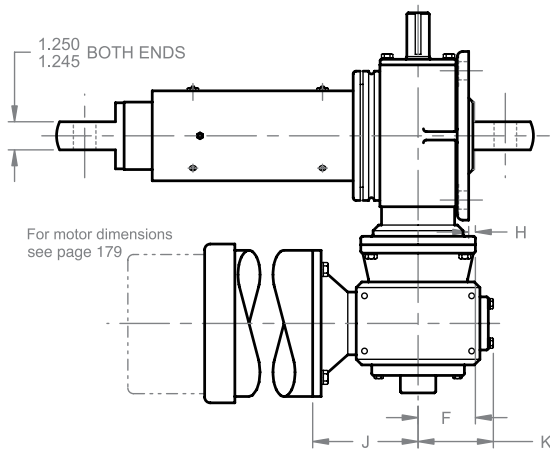

### REDUCER DIMENSIONS

HP	1, 1 1/2, 2	3, 5
A	8 11/32	8 29/32
B	11 21/32	13 17/32
C	1 3/4	2 5/8
D	3 3/8	4 7/16
E	8 7/16	11 11/16
F	2 3/4	3 7/8
G	4 15/32	4 15/32
H	0	1 1/8
J	4 11/16	5 3/4
K	3 11/32	4 5/16

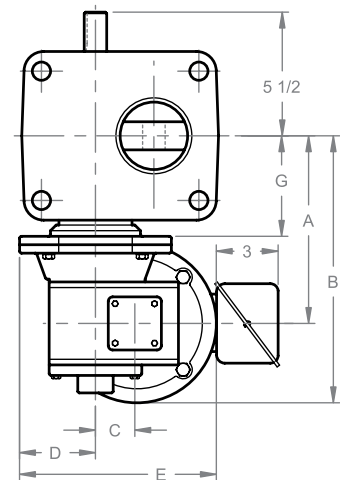

NOTE: FOR CAPACITY AND MAXIMUM RISE SEE PAGE 128.

Note: Drawings are artist's conception — not for certification; dimensions are subject to change without notice.

# ELECTRIC CYLINDERS

## 20 TON ELECTRIC CYLINDER

ECA (ACME SCREW)  
ECB (BALL SCREW)

### STANDARD

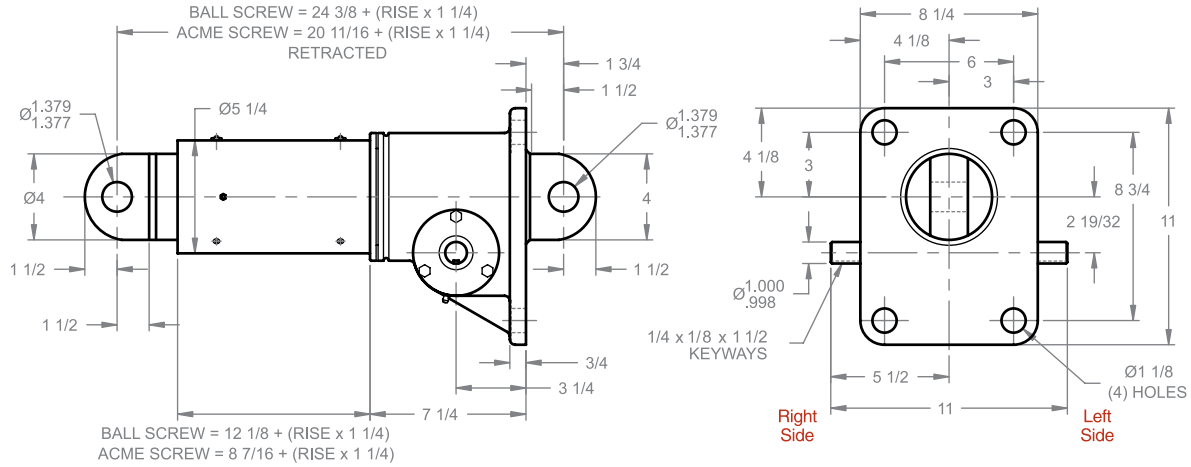

### MOTOR MOUNT

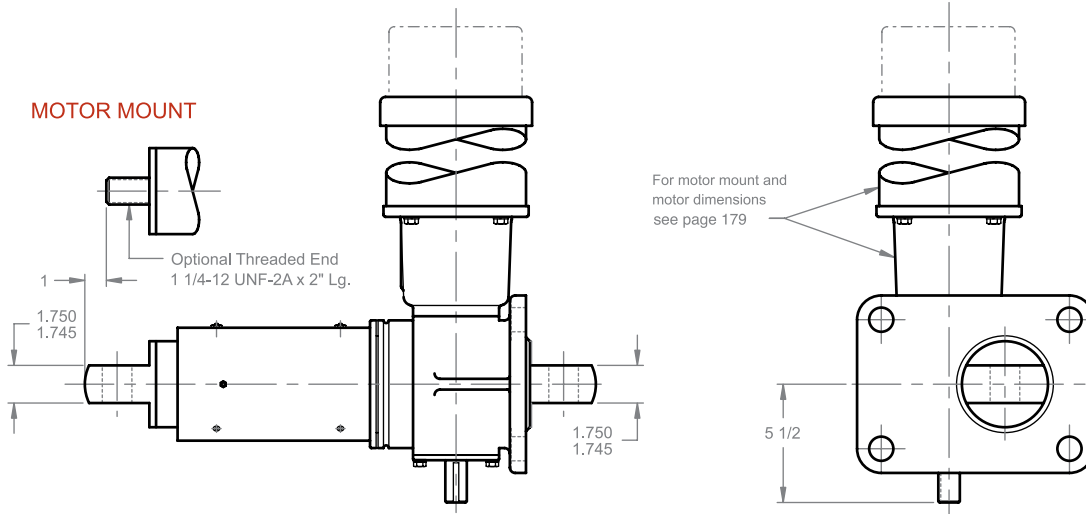

### ComDRIVE®

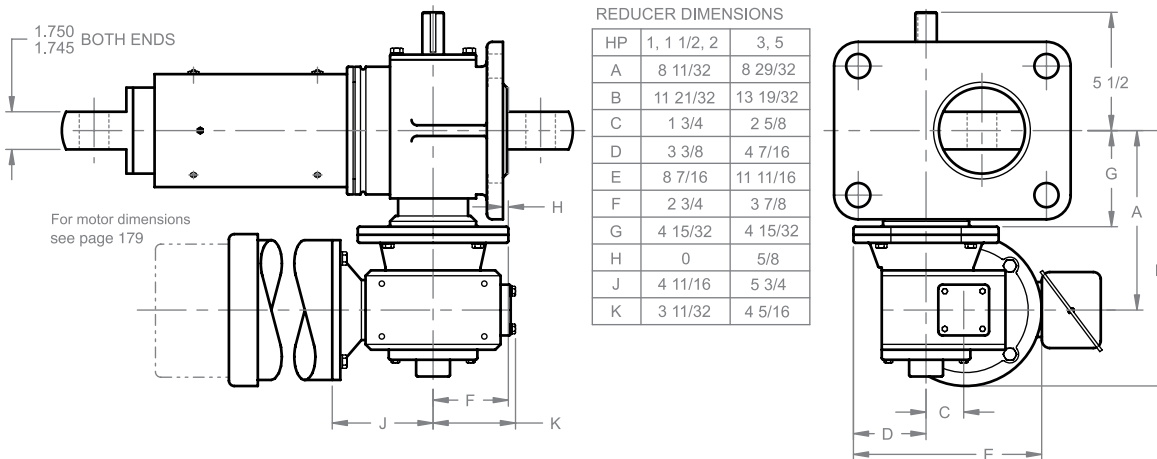

NOTE: FOR CAPACITY AND MAXIMUM RISE SEE PAGE 129.

Note: Drawings are artist's conception — not for certification; dimensions are subject to change without notice.

# INTEGRATED ACTUATORS



Joyce integrated actuators are designed to lift and precisely position loads of up to one ton. Translating tube (TT) integrated actuators are well suited for use in industrial environments where protection of the lifting screw mechanism is critical and low maintenance is desired. Traveling nut (TN) integrated actuators are best suited for use in environments that are relatively clean and free of dust.

Requiring only electric power, Joyce integrated actuators may be used in place of hydraulic cylinders, eliminating the cost and potential for leaks associated with hydraulic systems.

Integrated actuators include NEMA 56C-face motor flanges, and are capable of moving at speeds up to 345 inches per minute. Dynamic speed/load rating charts can be viewed along with product drawings on pages 139 to 142. Both acme screw (IA, DIA) and ball screw (BIA, HBIA) models are designed to operate at the charted capacities under both tension and compression loading.

#### Joyce Integrated Actuator Features and Benefits:

- Chrome plated (BIA, HBIA) or stainless steel (IA, DIA) inner cylinder tube resists harsh contaminants while providing smooth cylinder translation.
- Tube seals retain lubrication while preventing dirt and grime from entering the internal cavity and contaminating the lifting screw.
- Aluminum cast housing provides durable protection for screw and internal components.
- Rigid cylinder tube guide bearings provide resistance to buckling (external guides are required when side loads are present).
- Alloy steel input shafts riding on tapered roller bearings provide proper wormgear alignment for increased service life.
- Input shaft seals prevent the loss of lubrication.

Joyce can customize integrated actuators to meet your specifications.

#### Joyce offers Integrated Actuators in the following designs:

- **Translating tube**
- **Traveling nut**

An illustration and a guide for ordering are on pages 136 and 137.

# INTEGRATED ACTUATORS

## Integrated Actuator

(Example: IA51TT-6-LJ20-MMAA-S)

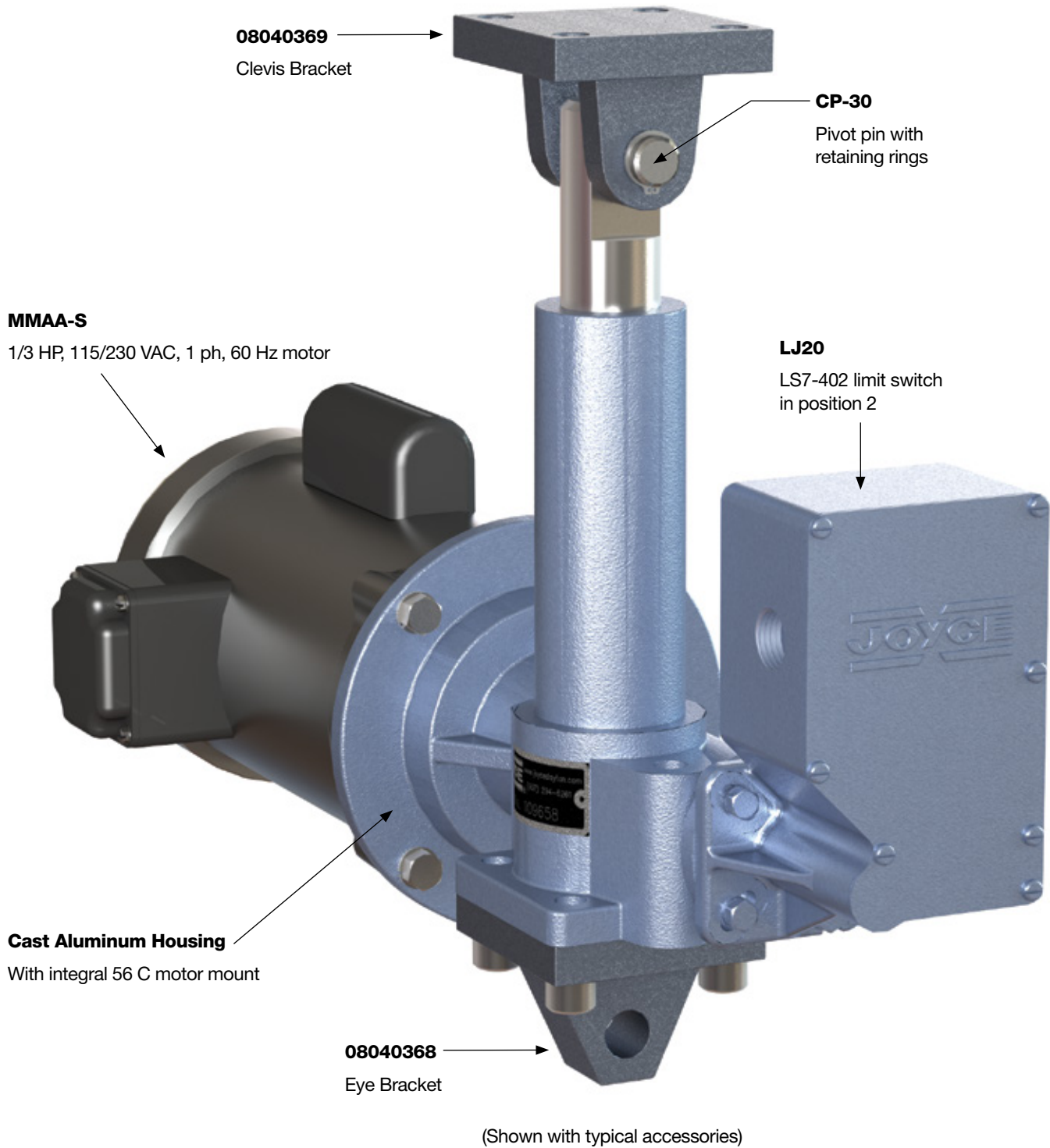



# INTEGRATED ACTUATORS ORDERING INFORMATION

**Instructions:** Select a model number from this chart.

ACME 1" diameter, .25" pitch	ACME 1" diameter, .25" pitch/ .50" lead	Ball 1" diameter, .25" pitch	Ball 1" diameter, 1.00" pitch
IA51 IA201	DIA51* DIA201*	BIA51* BIA201*	HBIA51*

**Important Note:** \*Integrated actuators may lower under load. Brake motors or external locking systems are recommended.

## Sample Part Number: IA51-TT-6.00-LJ20-MMAA-S

Integrated Actuator Configuration	
<b>TT</b> Translating Tube	<b>TN</b> Keyed for Traveling Nut

Integrated Actuator Rise
Rise is travel expressed in inches and not the actual tube length. Contact Joyce for rises greater than 24"

Left Side Shaft Code	Right Side Shaft Code
<p>XXXX=Remove Shaft STDX=Standard CUST=Custom</p> <p>LJ10 LJ20 LJ30 LJ40</p> <p>See limit switch positions from chart below</p>	<p>RMMT=Remove Motor Mount MMA=Standard</p> <p>Motor code from chart below</p>

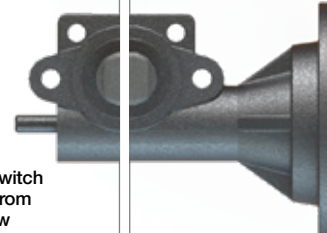

Limit Switches	1	2	3	4
Position				
Left side Shaft				
Code	LJ10	LJ20	LJ30	LJ40

Motors	
Size	Code
1/4 HP	K
1/3 HP	A
1/2 HP	B
3/4 HP	C
No Motor	X

Standard Motors						
Voltage	Speed (rpm)	1/4 HP	1/3 HP	1/2 HP	3/4 HP	
115/230 VAC Single Phase	1140			X	X	
115/230 VAC Single Phase	1725	X	X	X	X	
115/230 VAC Single Phase w/brake	1725		X	X	X	
230/460 VAC Three Phase	1140	X	X	X	X	
230/460 VAC Three Phase	1725	X	X	X	X	
230/460 VAC Three Phase w/brake	1725	X	X	X	X	
12 VDC Permanent Magnet	1800	X	X	X	X	
24 VDC Permanent Magnet	1800		X	X	X	
90 VDC Permanent Magnet	1750	X	X	X	X	
180 VDC Permanent Magnet	1750	X	X	X	X	

Options** (see chart to left)	
X	No additional options
M	Modify standard actuator
C12	12 VDC motor
C24	24 VDC motor
C90	90 VDC motor
C180	180 VDC motor
K	Brake motor
R	1140 RPM motor
S	Single phase 115/230 1-ph. 60 Hz

\*\* Specify as many options as needed.

Optional Accessories (p. 138)		
		
Clevis Bracket 08040369	Pivot Pin with retaining rings CP-30	Eye Bracket 08040368

# INTEGRATED ACTUATORS OPTIONS

## Motors

Standard 56C-NEMA frame motors are available in:

### AC Motors

- 1/4, 1/3, 1/2, and 3/4 HP
- 1140 or 1725 rpm
- Single or three phase
- With or without brake

### DC Motors

- 1/4, 1/3, 1/2, and 3/4 HP
- 1750 rpm or 1800 rpm
- 90 and 180 volts

## Ring Encoders

Contact Joyce with your requirements.

### Limit Switch (LS7 ONLY)

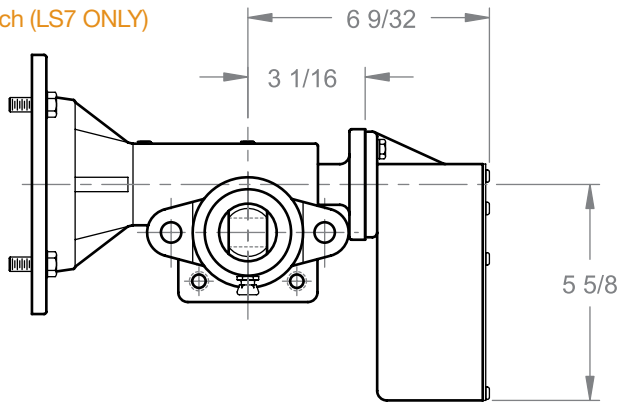

### Limit Switch Position Nos.

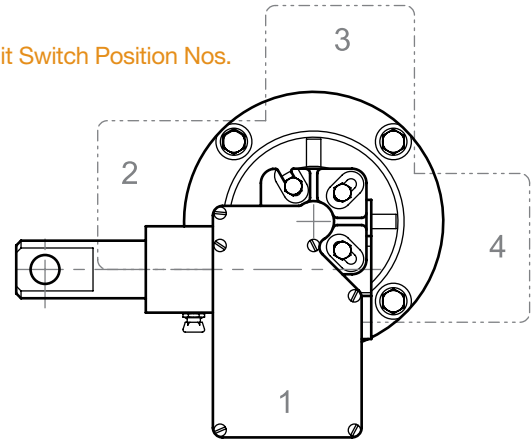

### Clevis Accessories

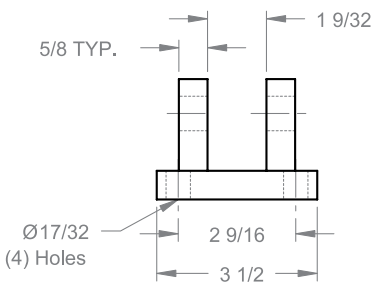

Clevis Bracket #08040369

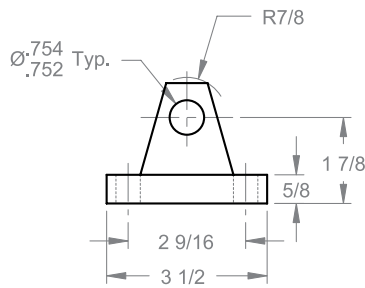

Eye Bracket #08040368

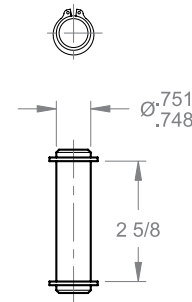
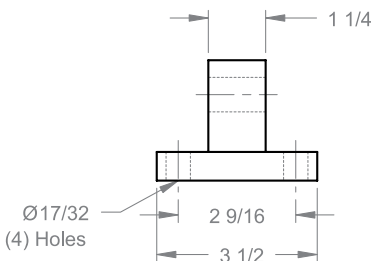

Pivot Pin  
With Retaining Rings  
CP-30

Note: Drawings are artist's conception — not for certification; dimensions are subject to change without notice.

# INTEGRATED ACTUATORS

## 250-2000 POUND INTEGRATED ACME SCREW

IA 51TT / DIA 51TT  
IA 201TT / DIA 201TT

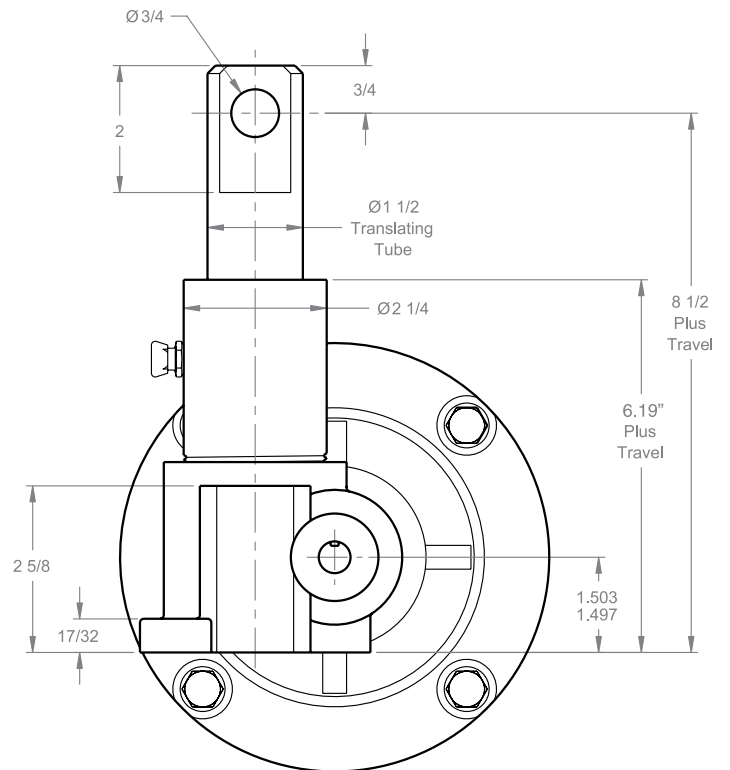
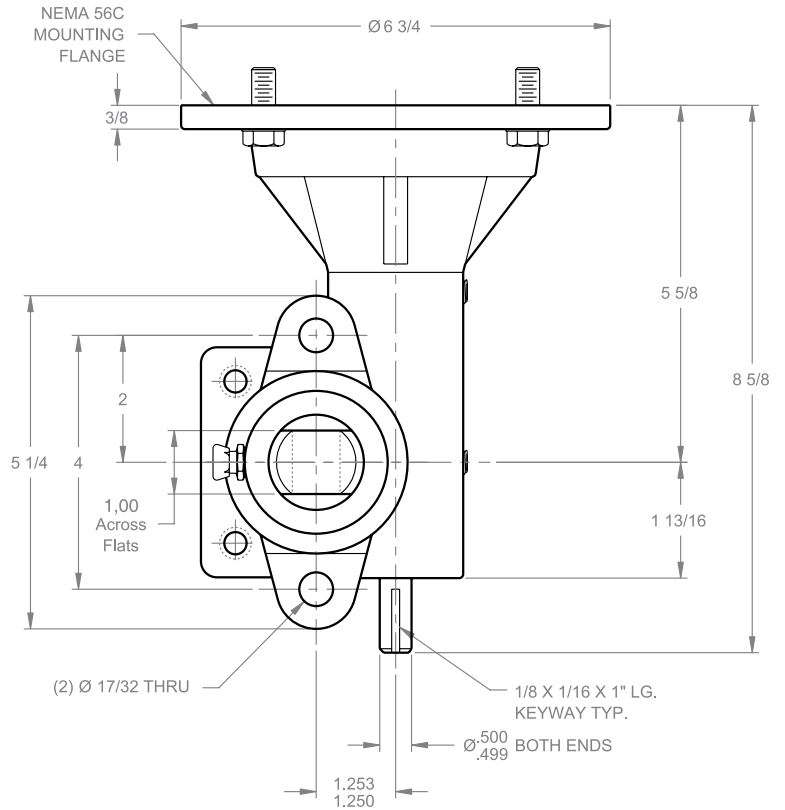
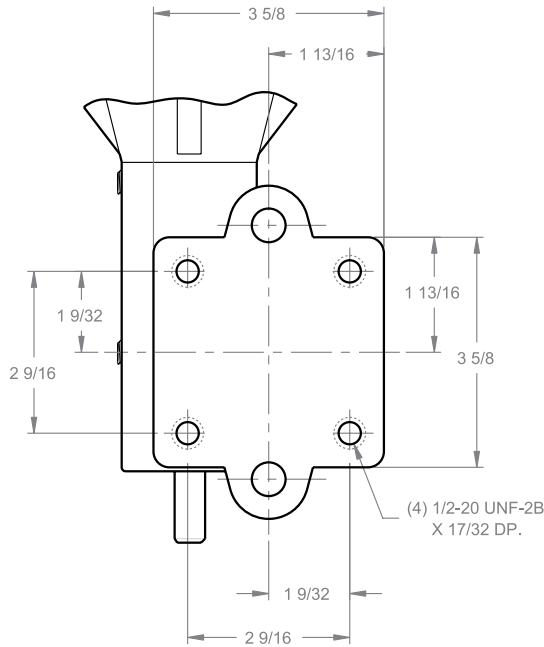

Model Number	IA51TT		DIA51TT		
	IA201TT		DIA201TT		
ACME Threaded Lifting Screw	1" diameter .25" pitch		1" diameter .25" pitch .50" lead		
Wormgear Ratio	5:1		5:1		
	20:1		20:1		
Worm Shaft Turns/1" Travel	20		10		
	80		40		
Motor RPM	1140	1725	1140	1725	
Lifting Speed (Inches/Minute)	57	86	114	172	
	14	21	28	43	
Rated Loads (Lbs.)	1/3 HP Motor	550	375	375	250
		1775	1225	1250	850
	1/2 HP Motor	850	550	575	400
		2000	1850	1875	1300
	3/4 HP Motor	1250	850	875	600
		2000	2000	2000	1950

**Lead:** The distance traveled axially in one rotation of the lifting screw.

**Pitch:** The distance from a point on a screw thread to a corresponding point on the next thread, measured axially.

**Important Note:** DIA models may lower under load. Brake motors or external locking systems are recommended.

Note: Drawings are artist's conception — not for certification; dimensions are subject to change without notice.

# INTEGRATED ACTUATORS

## 250-2000 POUND INTEGRATED ACME SCREW

IA 51TN / DIA 51TN  
IA 201TN / DIA 201TN

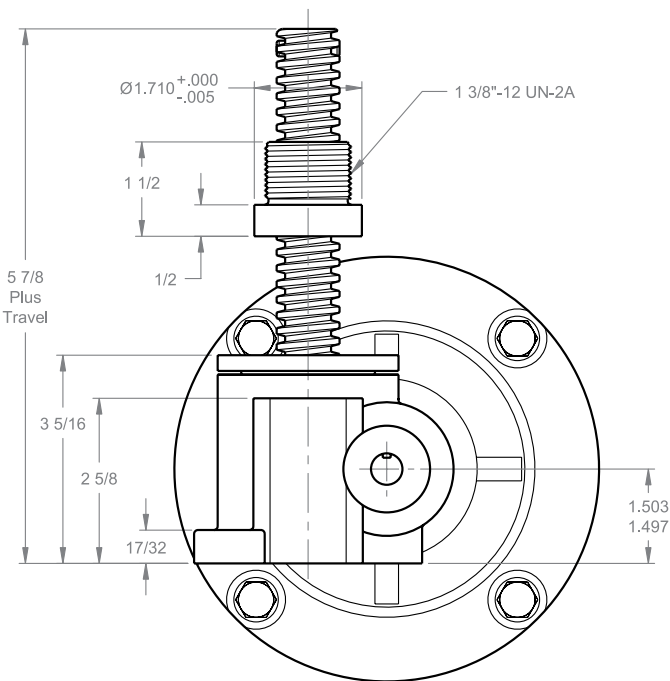
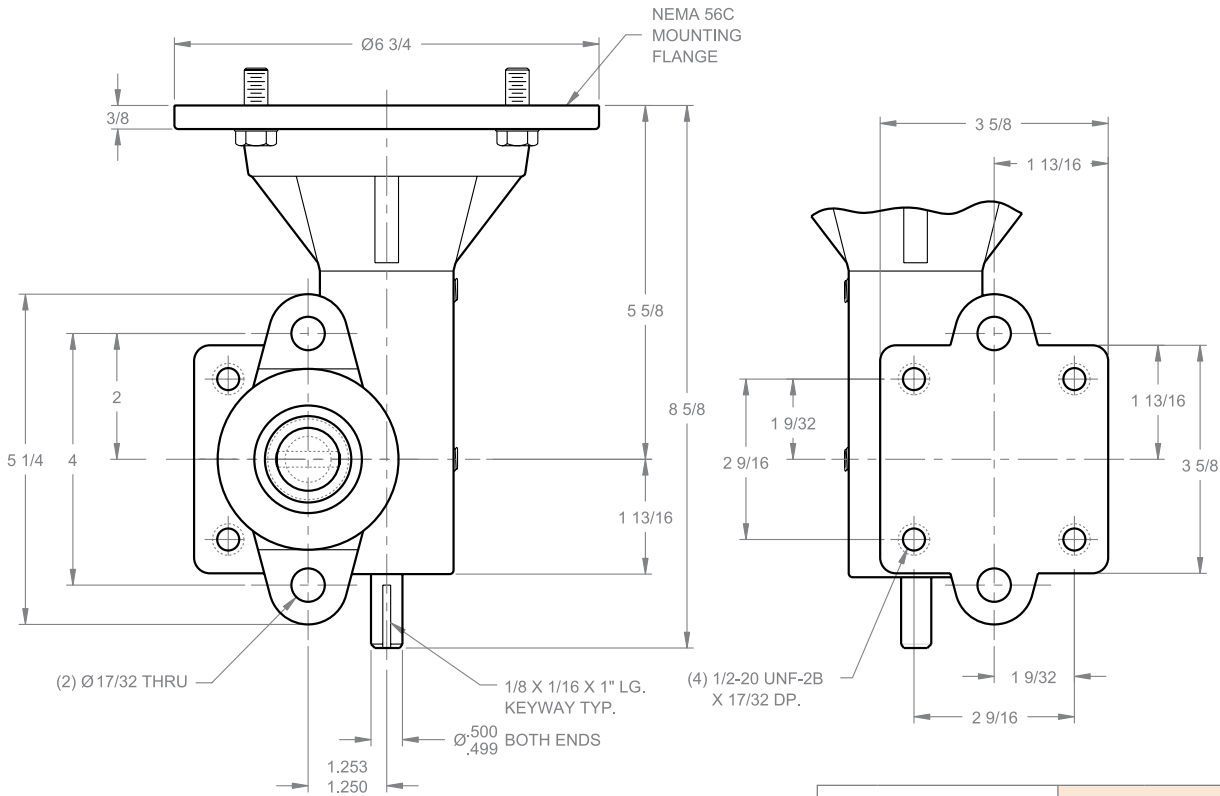

Model Number	IA51TN		DIA51TN*		
	IA201TN		DIA201TN*		
ACME Threaded Lifting Screw	1" diameter .25" pitch		1" diameter .25" pitch .50" lead		
Wormgear Ratio	5:1		5:1		
	20:1		20:1		
Worm Shaft Turns/1" Travel	20		10		
	80		40		
Motor RPM	1140	1725	1140	1725	
Lifting Speed Inches/Minute	57	86	114	172	
	14	21	28	43	
Rated Loads (Lbs.)	1/3 HP Motor	550	375	375	250
		1775	1225	1250	850
	1/2 HP Motor	850	550	575	400
		2000	1850	1875	1300
	3/4 HP Motor	1250	850	875	600
		2000	2000	2000	1950

**Lead:** The distance traveled axially in one rotation of the lifting screw.

**Pitch:** The distance from a point on a screw thread to a corresponding point on the next thread, measured axially.

**Important Note:** \*DIA models may lower under load. Brake motors or external locking systems are recommended.

Note: Drawings are artist's conception — not for certification; dimensions are subject to change without notice.

# INTEGRATED ACTUATORS

## 100-2000 POUND INTEGRATED BALL SCREW

BIA 51TT / HBIA 51TT  
BIA 201TT

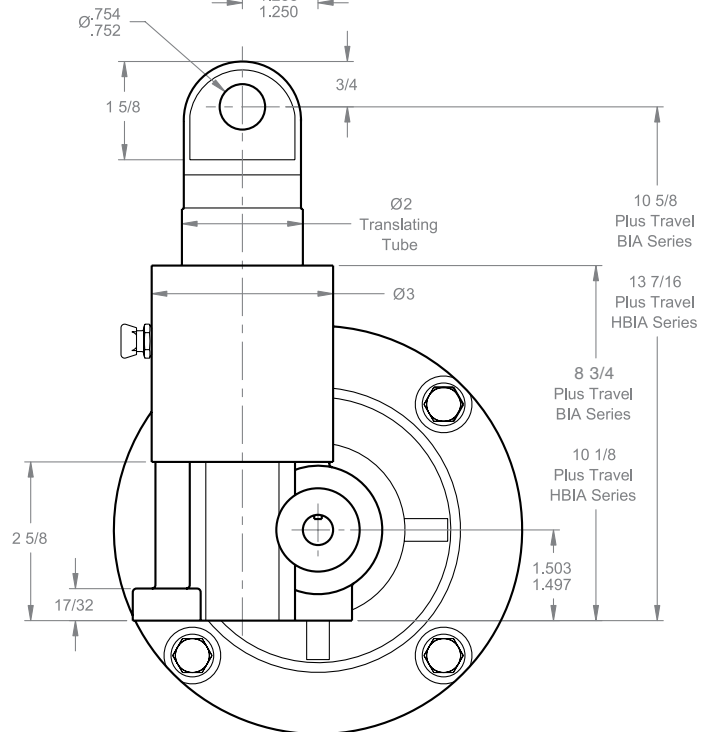
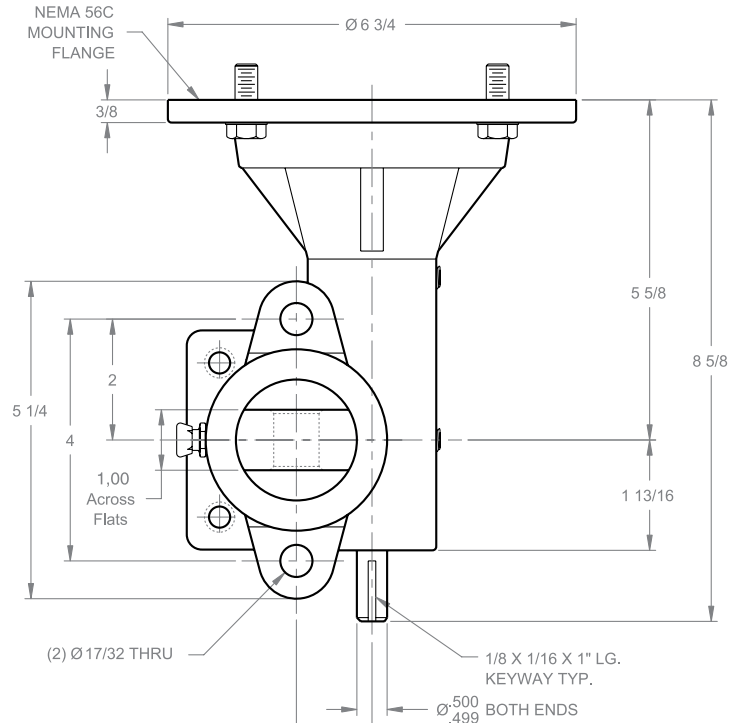
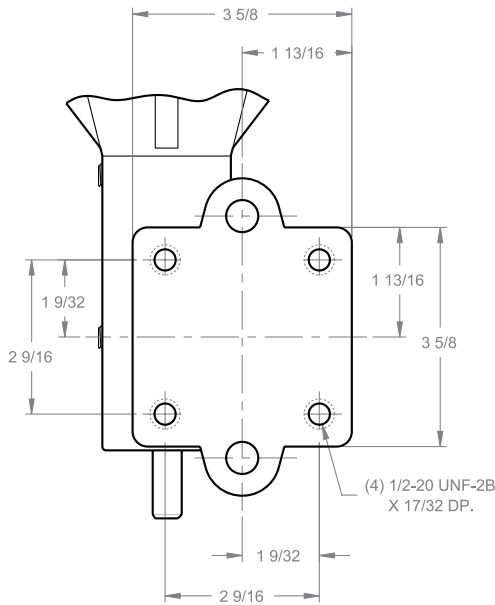

Model Number	BIA51TT*		HBIA51TT*		
	BIA201TT*		-		
Ball Screw	1" diameter .250" lead ball screw		1" diameter 1.000" lead ball screw		
Wormgear Ratio	5:1		5:1		
	20:1		-		
Worm Shaft Turns/1" Travel	20		5		
	80		-		
Motor RPM	1140	1725	1140	1725	
Lifting Speed Inches/Minute	57	86	228	345	
	14	21	-	-	
Rated Loads (lbs.)	1/4 HP Motor	925	625	225	100
		2000	2000	-	-
	1/3 HP Motor	1225	825	300	200
		2000	2000	-	-
	1/2 HP Motor	1850	1250	450	300
		2000	2000	-	-
	3/4 HP Motor	2000	1875	700	450
		2000	2000	-	-

**Lead:** The distance traveled axially in one rotation of the lifting screw.

**Pitch:** The distance from a point on a screw thread to a corresponding point on the next thread, measured axially.

**Important Note:** \*BIA & HBIA models are not self-locking. Brake motors or external locking systems are required.

Note: Drawings are artist's conception — not for certification; dimensions are subject to change without notice.



# LINEAR ACTUATORS

Joyce linear actuators are designed to lift and precisely position loads of up to 1500 pounds. They are built with cast aluminum housings, include motors (120 VAC or 12 VDC), and are best suited for use in environments that are protected from the elements. A spring brake ensures that the actuators hold position when power is off. The maximum speed, which varies with load, is about 50 inches per minute (LA155).

Joyce linear actuators are designed for either double clevis or trunnion mounting. Standard travel lengths include 3, 6, 12, 18, and 24 inches. The restraining torque for the translating tube is 190 inch-pounds.

Specifications for AC models LA155L & LA155P:

- 120 VAC
- Limit switch available (LA155L)
- Limit switch and potentiometer available (LA155P)
- Approximate weight, 25 lbs + 0.5 lbs per inch of travel

Specifications for 12 VDC models LA152L & LA152C:

- 12 VDC
- Approximate weight, 19 lbs + 0.5 lbs per inch of travel

The LA Series Linear Actuators are no longer available, however Joyce offers several other actuator options. We want you to find a product that meets your requirements.

Contact us at:

[sales@joycedayton.com](mailto:sales@joycedayton.com)

800-523-5204 (USA and Canada)

937-294-6261

- Joyce offers Linear Actuators in several configurations including:
- 120 VAC with limit switch
  - 120 VAC with limit switch and potentiometer
  - 12 VDC with limit switch
  - 12 VDC with clutch

A guide for ordering is on page 144.







# LINEAR ACTUATORS

## 1500 POUND DC WITH LIMIT SWITCH

LA 152L

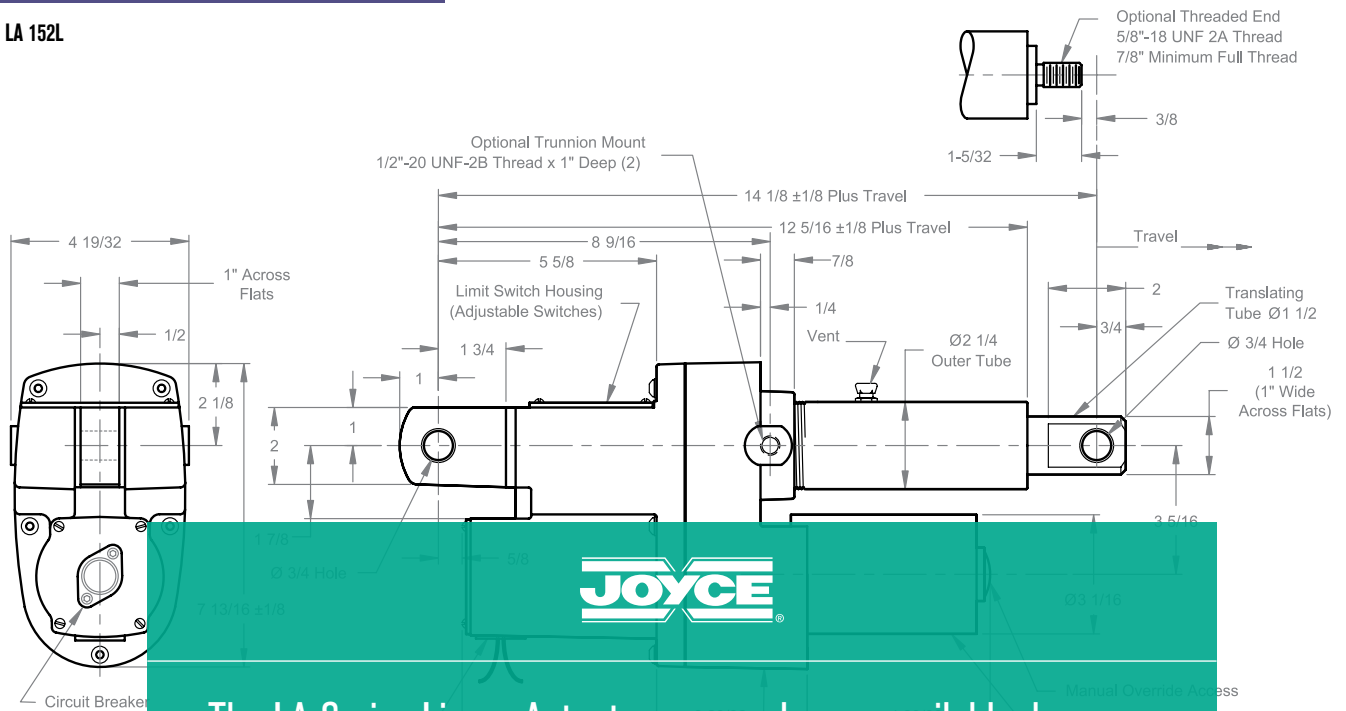

The LA Series Linear Actuators are no longer available, however Joyce offers several other actuator options. We want you to find a product that meets your requirements.

Contact us at:  
[sales@joycedayton.com](mailto:sales@joycedayton.com)  
 800-523-5204 (USA and Canada)  
 937-294-6261

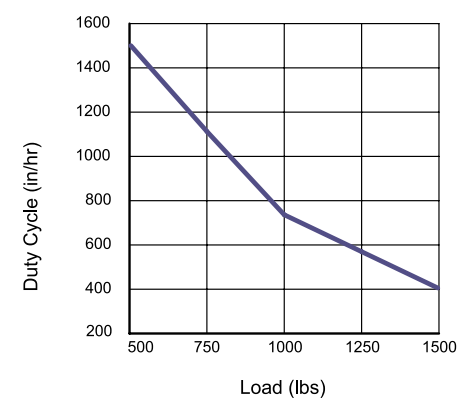

Duty Cycle ratings represent total travel per hour with equally timed intervals between cycles.

Note: Drawings are artist's conception — not for certification; dimensions are subject to change without notice.

# LINEAR ACTUATORS

## 1500 POUND DC WITH SLIP CLUTCH

LA 152C

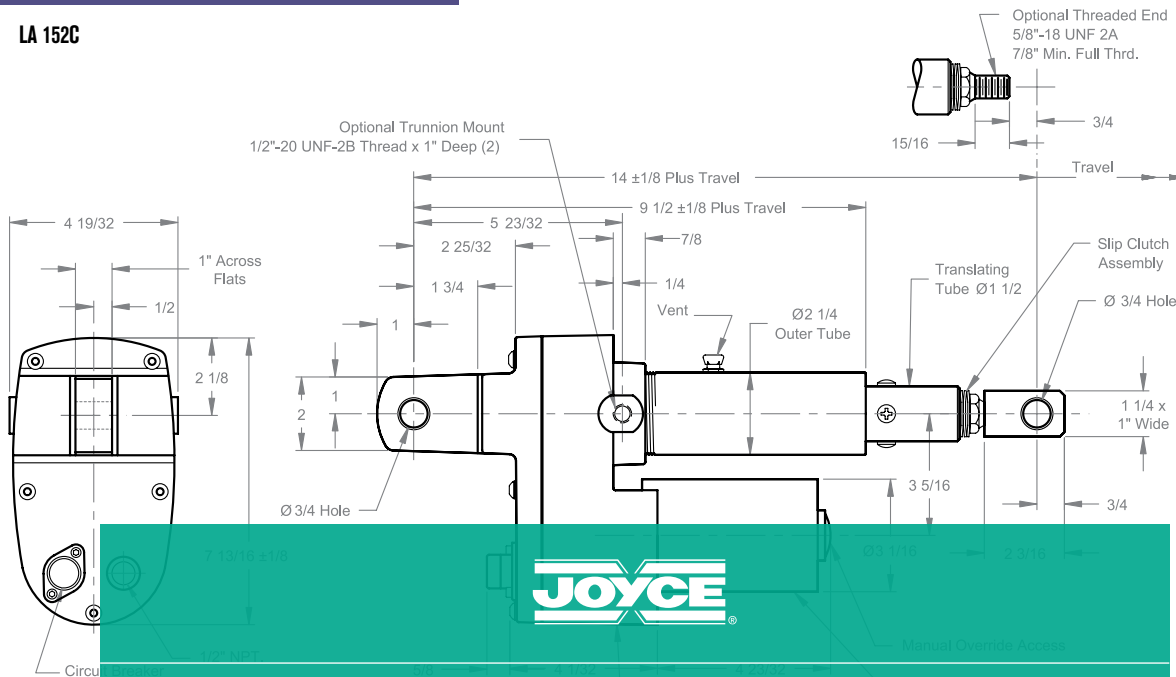

The LA Series Linear Actuators are no longer available, however  
Joyce offers several other actuator options.

We want you to find a product that meets your requirements.

Contact us at:

[sales@joycedayton.com](mailto:sales@joycedayton.com)

800-523-5204 (USA and Canada)

937-294-6261

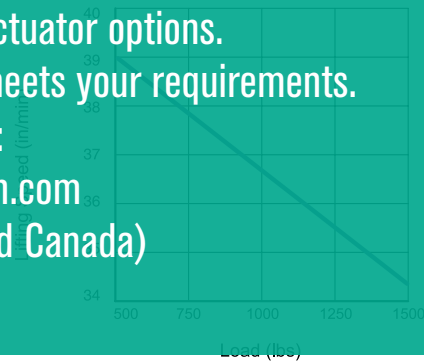

Duty Cycle ratings represent total travel per hour with equally timed intervals between cycles.

Note: Drawings are artist's conception — not for certification; dimensions are subject to change without notice.

# LINEAR ACTUATORS

## 1500 POUND AC WITH LIMIT SWITCH

LA 155L  
LA 155P

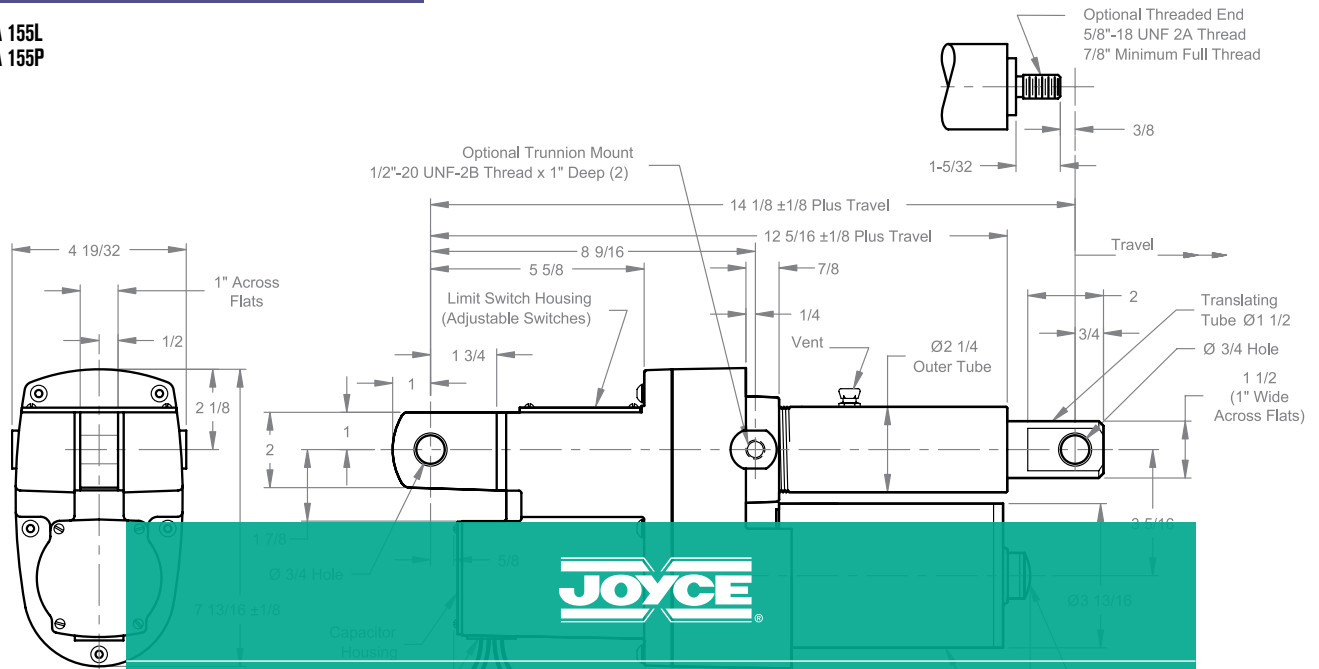

The LA Series Linear Actuators are no longer available, however Joycean offers several other actuator options. We want you to find a product that meets your requirements.

Direction	L1 (Line)	L2 (Neutral)	Ground
Extend	Blue	White	
Retract	Red	White	

Contact us at:

[sales@joycedayton.com](mailto:sales@joycedayton.com)  
800-523-5204 (USA and Canada)  
937-294-6261

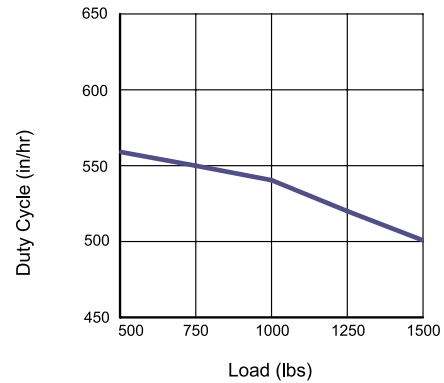
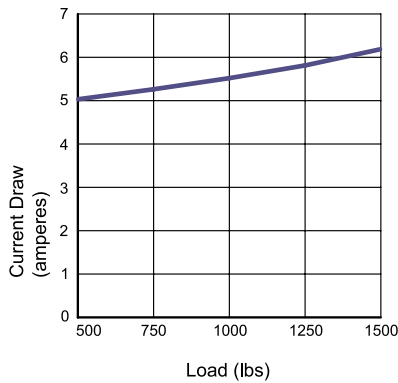
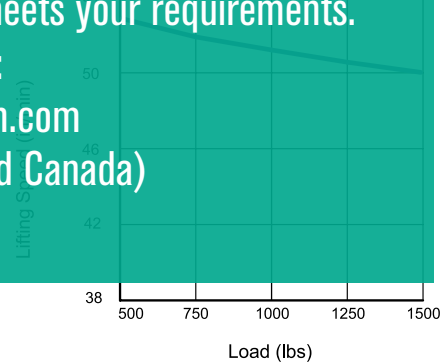

Duty Cycle ratings represent total travel per hour with equally timed intervals between cycles.

Note: Drawings are artist's conception — not for certification; dimensions are subject to change without notice.

Joyce Bevel Gear® Jacks (BG) offer higher efficiency and greater speed than other mechanical screw jacks. At the same time, bevel gear jacks with single lead screws (S series) provide the benefits of a self-locking screw – no special brake is required to prevent the jack from lowering under load. Spiral bevel gears increase strength for higher capacities.

Bevel gear jacks are available in 7.5-ton to 100-ton static capacities with either single lead S series or double lead D series lifting screws. Standard jacks have right hand screw threads. Left hand screw threads are available as an option.

Bevel gear jacks also act as miter boxes, making them an ideal choice for multi-jack systems. As many as three output shafts may be specified for mounting motors, limit switches, readout devices and other accessories. See page 195 for an example of a bevel gear jack system. Note that right hand and left hand screw threads are alternated in the layout.

Many options are available and all jack designs can be fitted with protective boots.

Joyce can customize bevel gear jacks to meet your requirements.

**To properly size jacks, follow the design tips on page 151 and refer to the Thermal Graphs and Column Load charts (pages 152 to 154). Use JAX® Online software to determine dynamic capacity of jacks or contact Joyce.**

# BEVEL GEAR JACKS



Joyce offers Bevel Gear Jacks in several designs including:

- Translating
- Keyed for non-rotation
- Keyed for traveling nut (KFTN)

A guide for ordering is on page 150.

# BEVEL GEAR JACKS ORDERING INFORMATION

**Instructions:** Select a model number from this chart.

Joyce Bevel Gear® Jacks	
BG150S	BG150D
BG250S	BG250D
BG375S	BG375D
BG450S	BG450D





Follow the design tips (pp. 151-154).  
Detailed product information (pp. 155-158).  
Right hand screw threads standard.

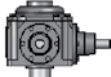

Bevel Gear Jack Rise
Rise is travel expressed in inches and not the actual screw length.

Screw Stops (p. 10) and Boots (pp. 170-173)
Screw stops are optional on Bevel gear jacks. When specified, the closed height of the jack and protection tube length may be increased.

## Sample Part Number: BG150SU2S-12.25-STDX-STDX-STDX-X

Jack Configuration	
	
U=Upright	I=Inverted

End Conditions			
			
1=T1 (plain end)	2=T2 (load pad)	3=T3 (threaded end)	4=T4 (male clevis)

Jack Design		
		
S=Translating	K=Keyed for Non Rotation	N=Traveling Nut

Encoders (pp. 176-177)	
ENCA=Absolute Encoder 0-10 VDC, programmable	
ENCB=Absolute Encoder 4-20mA, programmable	
ENCC=Absolute Encoder CAN Open	
ENCD=Absolute Encoder SSI	
ENCS=Stainless Steel Incremental Encoder 1024 PPR	
ENCX=Incremental Encoder 200 PPR	
ENCY=Incremental Encoder 1024 PPR	

Shaft 2 Code

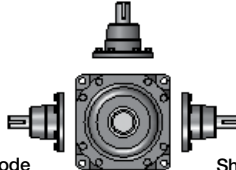







Shaft 1 Code      Shaft 3 Code

Shaft Codes
Three shaft codes must be specified for each jack. Electronic and mechanical limit switches may be substituted for the shaft code per the tables on this page.
STDX – Standard
XXXX – Input shaft not required
CUST – Custom
When ordering with only one input shaft, it is recommended to order the following configuration:
XXXX-STDX-XXXX

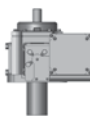
Additional Options*
X=Standard Jack, no additional options
S=Additional Specification Required (comment as necessary)
<b>Protective Boots pp. 170-173</b>
B=Protective Boot
D=Dual Protective Boot
<b>Finishes p. 182</b>
F1=Do not Paint
F2=Epoxy Paint
F3=Outdoor Paint Process
<b>ACME Screw</b>
L=Left Hand Screw
<b>Screw Stops</b>
ST0=Extending
ST1=Retracting
ST2=Both
* Specify as many options as needed

### Mechanical Limit Switches (p. 174)

Ordering Example: LA13

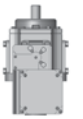
Models		Number of DPDT Switches (see p. 174)	Available Positions							
Model	Code		1	2	3	4	5	6	7	8
LS7-402	LI	NOTE: Will always be 0 for LS7 models								
LS8-402	LA									
LS8-404	LB									

Note: All BG jacks are available with all mounting positions.

# BEVEL GEAR JACKS SPECIFICATIONS AND DESIGN TIPS

Model	Dynamic Capacity	Static Load Capacity		Screw		Bevel Gear Ratio	Pinion Turns for 1" Travel	Pinion Torque (In. Lbs.)	Screw Torque	Jack Efficiency	Jack† Cooling Time	Base Weight (Lbs.)	Add for Each Inch of Travel (Lbs.)
		Upright Assembly: screw-in compression/ Inverted Assembly: screw-in tension	Upright Assembly: screw-in tension/ Inverted Assembly: Screw-in compression	Dia.	Pitch/Lead								
BG150-S	Please use JAX® Online software or contact Joyce	14,000 lbs.	14,000 lbs.	1 1/2"	.375P STUB ACME	2.69:1	7.18	.059W*	.151W*	38.5%	38 min.	42	.8
BG150-D*					.250P / .500L ACME 2C	2.69:1	5.38	.066W*	.169W*	45.6%	38 min.	42	.8
BG250-S		30,000 lbs.	30,000 lbs.	2 1/2"	.500P ACME 2C	2.15:1	4.31	.111W*	.227W*	34.2%	82 min.	140	2.6
BG250-D*					.375P / .750L ACME 2C	2.15:1	2.87	.133W*	.272W*	42.6%	82 min.	140	2.6
BG375-S		66,000 lbs.	40,000 lbs.	3 3/4"	.666P ACME 2C	3.52:1	5.29	.098W*	.329W*	31.5%	192 min.	230	4.1
BG375-D*					.666P / 1.333L STUB ACME	3.52:1	2.64	.134W*	.448W*	46.0%	192 min.	230	4.1
BG450-S		218,000 lbs.	200,000 lbs.	4 1/2"	.500P ACME 2C	3:1	6	.125W*	.356W*	21.9%	262 min.	650	5.5
BG450-D*					.500P / 1.00L ACME 2C	3:1	3	.154W*	.438W*	35.5%	262 min.	650	5.5

**Important Note:** \*Not self-locking, may lower under load. Brake motors or external locking systems are recommended.

**D:** Double Lead Screws.

**S:** Single Lead Screws. These jacks are self-locking.

**\*W:** Load in Pounds.

**Pinion Torque:** The torque required to continuously raise a given load.

**Screw Torque:** The torque required to resist screw rotation (translating jack design) and traveling nut rotation (keyed for traveling nut design).

**Lead:** The distance traveled axially in one rotation of the lifting screw.

**Pitch:** The distance from a point on the screw thread to a corresponding point on the next thread, measured axially.

†: Cooling time based on time to cool from 200°F to 70°F (ambient).

## Design Tips:

- A PV (pressure/velocity) value must be calculated for each application. The continuous running time should not exceed the corresponding T (time) value. Refer to instructions and graphs on pages 152 and 153.
- Cooling time data on these charts is calculated based on limiting the lifting nut temperature rise from 70°F to 200°F (100° below dropping point of grease).
- Check single lead versus double lead screws in each case. A double lead screw may be the appropriate choice due to increased efficiency while offering the same performance characteristics.
- JAX® Online software is a useful design aid to determine the following:
  - The allowable static compression load for a given rise (or use Column Loading Chart on page 154)
  - The allowable dynamic load for a given rise
  - System horsepower and torque – also see item #5
- When a direct motor drive is used in a system, consideration must be given to the input starting torque requirements and the motor horsepower will need to be increased accordingly (JAX® Online software data may require additional scrutiny). Contact Joyce for assistance.
- When selecting multiple bevel gear jacks for an interconnected row or system (page 195) careful attention must be given to the input and output shaft rotations. For example, if the input shaft rotation on the first jack is clockwise, the output shaft(s) on that same jack will rotate counter-clockwise. To insure all jacks raise and lower in unison, alternating jacks must be specified with right and left hand acme screw threads. For example, if you have five jacks interconnected in a straight line and the first jack is right hand, the third and fifth jack will also need to be ordered as right hand and the second and fourth jack will need to be ordered as left hand. Bevel gear jacks are supplied standard with right hand acme screws. To order the left hand acme screw option, add an "L" to the end of your bevel gear jack part number as shown on page 150.
- Joyce Bevel Gear® "S" Series (single lead) jacks are inherently self-locking. A brake is required for "D" series (double lead) jacks, which may lower under load.
- Bevel gear jacks are furnished with one input shaft in position #2. Jacks may be ordered with up to three input shafts located at any combination of positions # 1, 2, or 3.
- Joyce Bevel Gear® jacks are designed for oil bath (EP-90 gear lubricant) or grease operation. The upper bearing is grease lubricated through a fitting on top of the jack. Grease must be applied directly to the lifting screw.
- Typically jacks are mounted upright with the base plate parallel to the horizon. If the base plate is oriented any other way, contact Joyce for lubrication and other instructions.

# BEVEL GEAR JACKS APPLICATION INFORMATION AND THERMAL GRAPHS

In many applications, Joyce Bevel Gear® jacks are more efficient and faster than wormgear driven jacks. To determine the suitability of a bevel gear jack for your application, use the steps below to calculate load, travel speed and duty cycle.

**Step 1** Determine load in pounds.

**Step 2** Determine velocity in feet / minute (fpm).

**Step 3** Determine duty cycle in terms of minutes operation / minutes resting (or time on / time off).

**Step 4** Calculate PV.  
 $PV = (\text{load} \times \text{velocity in fpm}) / 1000$

**Step 5** Calculate cooling time (T).  
 $T = \text{Cooling time (p. 151)} \times \frac{\text{time on}}{\text{time off}}$

**Step 6** Plot the points for PV and T on the appropriate graph (below or on the next page). If the point falls below the line, the application is satisfactory. If it is above the line, recalculate T for the next larger size jack. Each jack size has a different cooling time (p. 151).

**Step 7** Calculate horsepower.  
 $RPM = \text{Velocity in fpm} \times 12 \times \text{input turns per one-inch travel (from chart on p. 151)}$   
 $\text{Horsepower} = \text{Pinion torque (from chart)} \times \text{load} \times RPM$

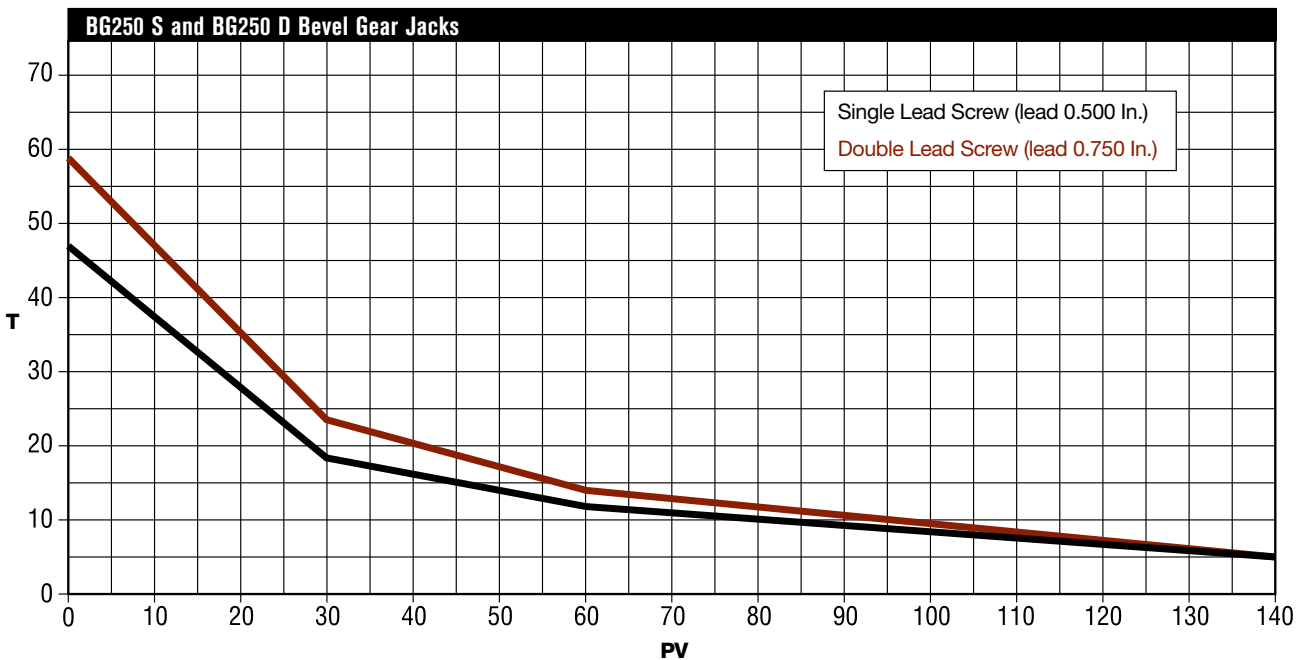
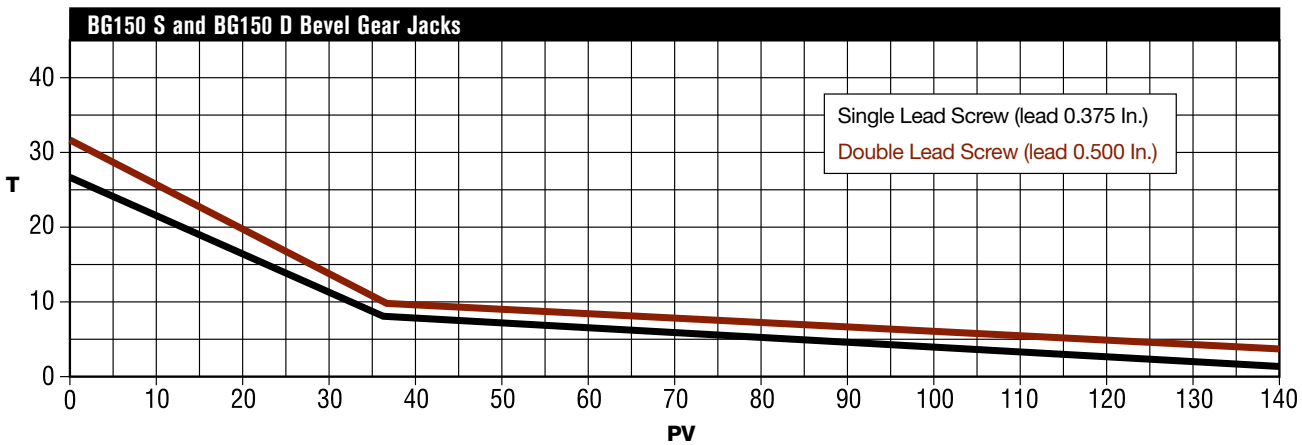

**Note:**  $PV = \frac{\text{load} \times \text{velocity (fpm)}}{1000}$

**T** = the maximum running time in minutes before a complete cooling time is required.



# BEVEL GEAR JACKS EXAMPLE AND THERMAL GRAPHS

**Example:** A 5000-pound load must be raised 30 inches in 15 seconds. The load remains in position for two minutes. It is then lowered and remains lowered for 30 seconds. The cycle begins again. Determine the appropriate bevel gear jacks and calculate horsepower required.

**Step 1** Load = 5000 pounds

**Step 2** Velocity = 30 inches in 15 seconds = 10 fpm

**Step 3** Duty cycle = Time on / Time off  
 Time on = 15 seconds up + 15 seconds down = 30 seconds = 0.5 min  
 Time off = 2 minutes up + 30 seconds down = 2 minutes 30 seconds = 2.5 minutes

**Step 4**  $PV = (5000 \times 10) / 1000 = 50$

**Step 5**  $T = 38$  (for BG150)  $\times (0.5 / 2.5) = 7.6$

**Step 6** The point for PV, 50. and T, 7.6 falls below the line for BG 150 D and above the line for BG 150S, therefore BG 150 D is appropriate. (reference BG150 chart on p. 152)

**Step 7**  $RPM = 10 \times 12 \times 5.38 = 645.6$   
 Horsepower =  $(.066 \times 5000 \times 646) / 63,025 = 3.38$

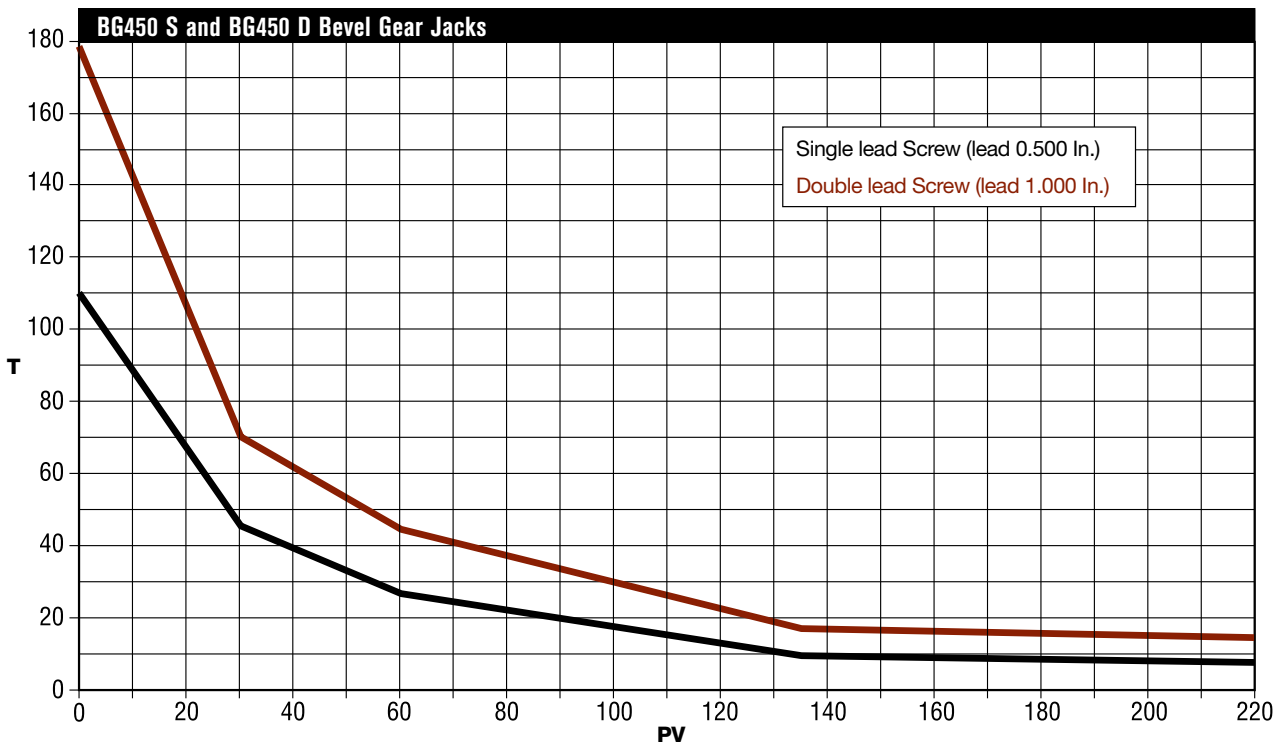
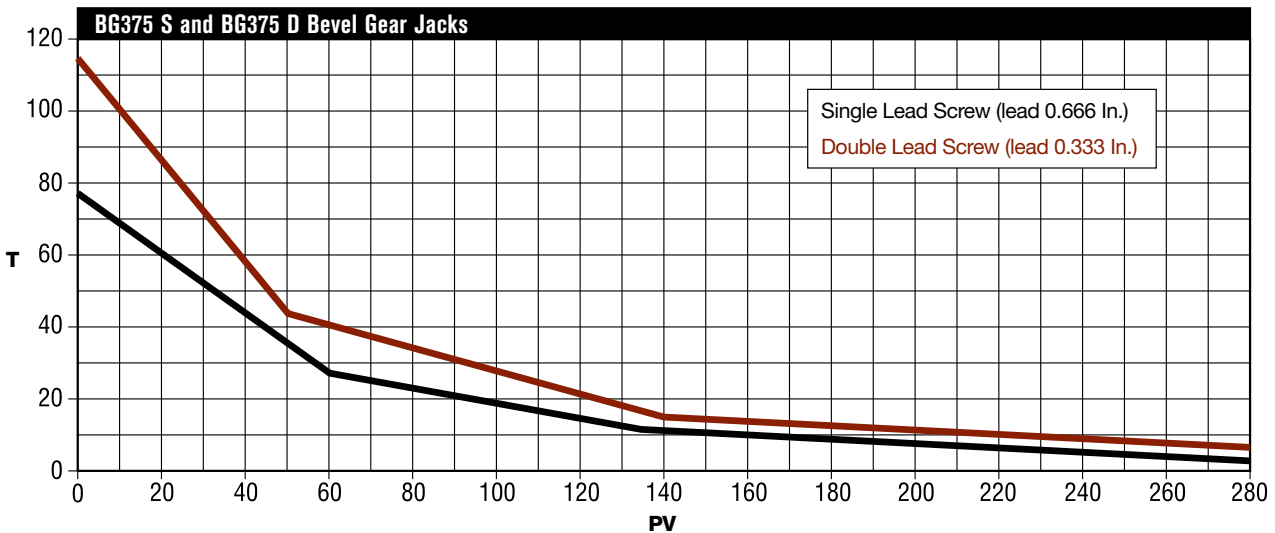

**Note:**  $PV = \frac{\text{load} \times \text{velocity (fpm)}}{1000}$

**T** = the maximum running time in minutes before a complete cooling time is required.

# BEVEL GEAR JACKS COLUMN LOADING

Joyce Bevel Gear® Jacks Column Loading Chart

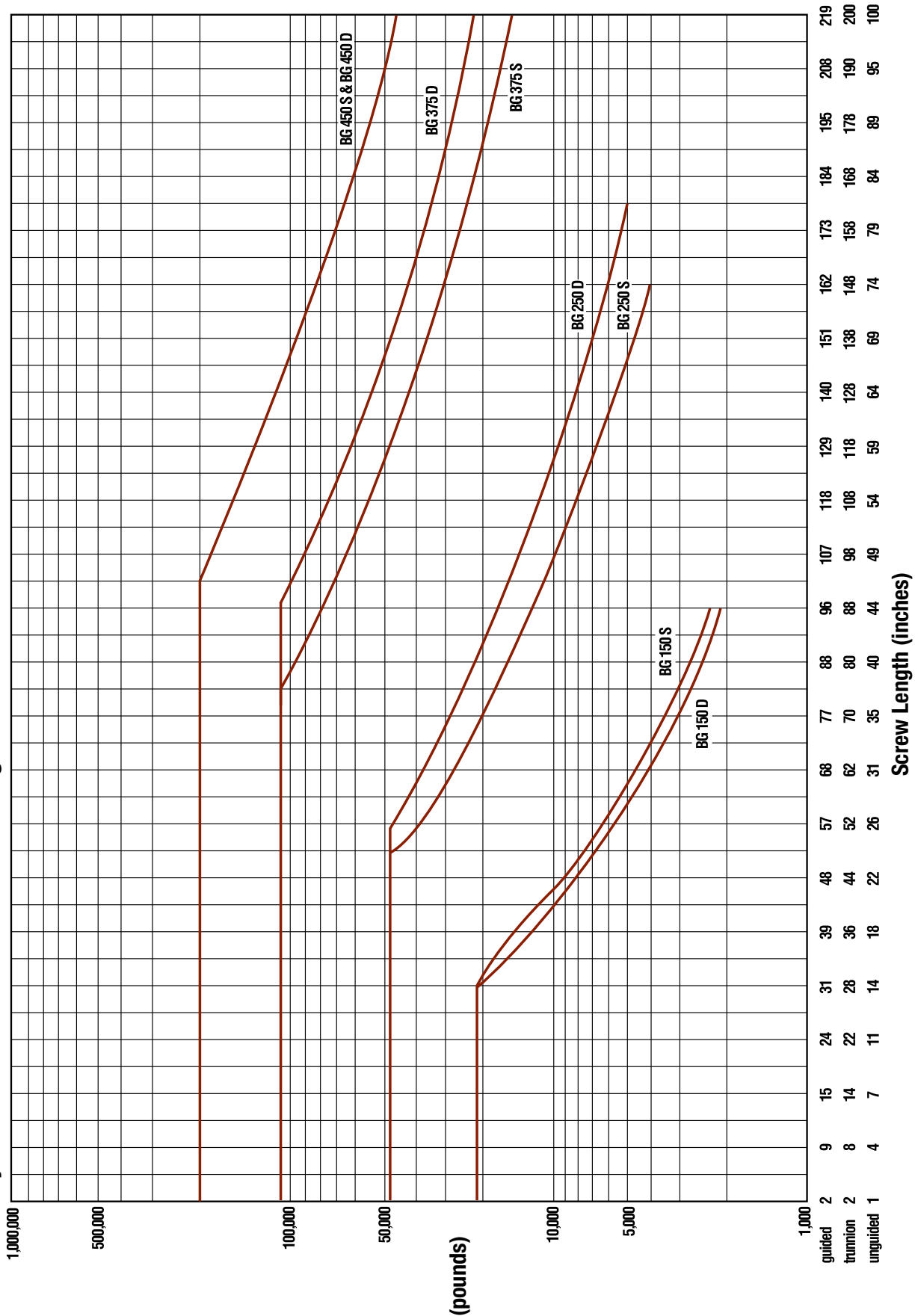

This chart includes a 2:1 Factor-of-Safety based on the Euler-Johnson equation for column loading (Oberg, Erik et al: Machinery's Handbook, 24th Edition. c. 1992 Industrial Press Inc.)  
The horizontal portion of each line represents the jack's maximum static capacity.

# BEVEL GEAR JACKS

**BG 150 - 1 1/2" SCREW**

**Upright**

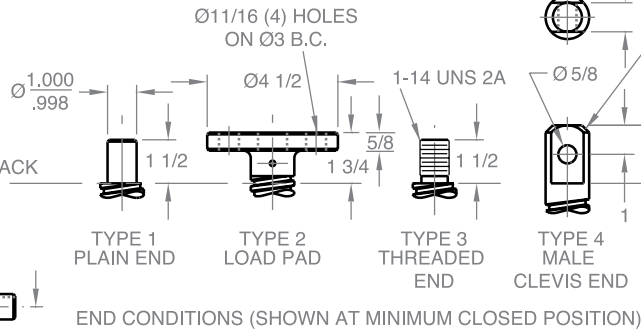
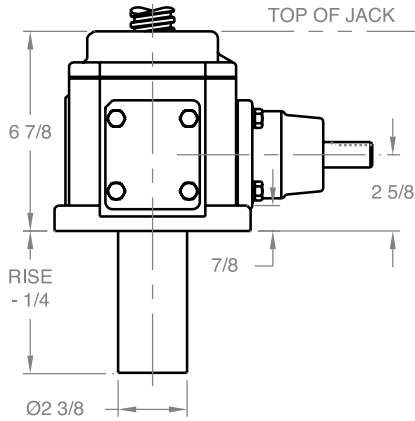

**Upright keyed**

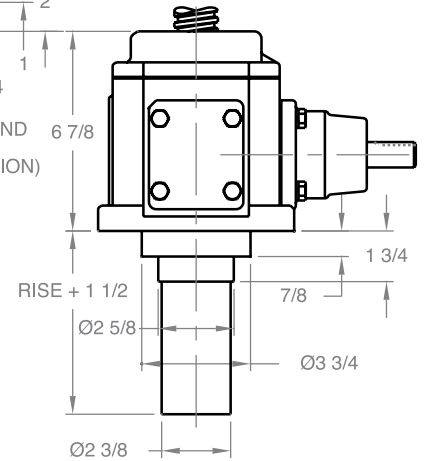

**Upright traveling nut**

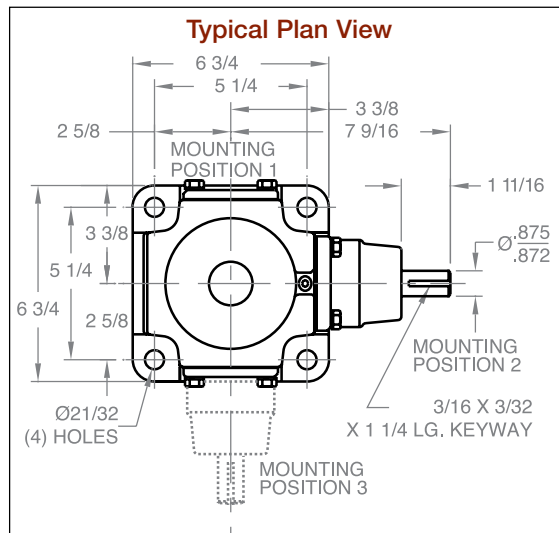
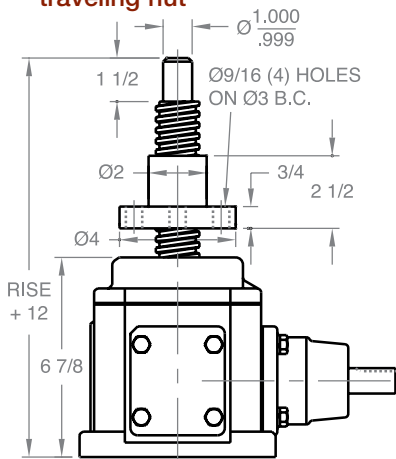

**Inverted traveling nut**

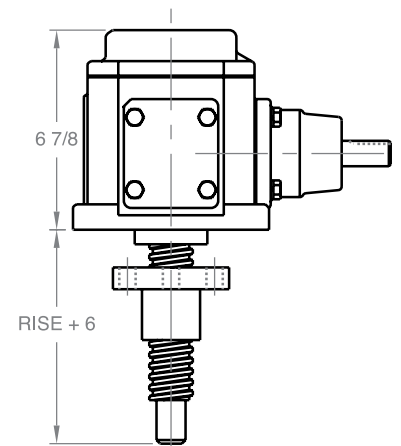

**Inverted**

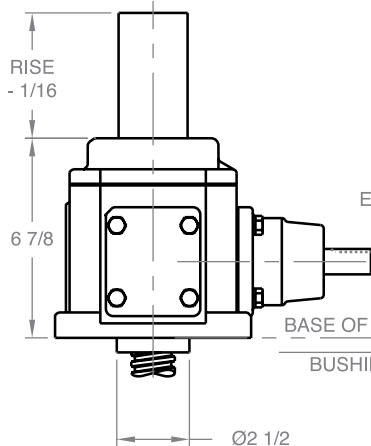

END CONDITIONS (SHOWN AT MINIMUM CLOSED POSITION)  
(DOES NOT APPLY TO INVERTED KEYED JACK)

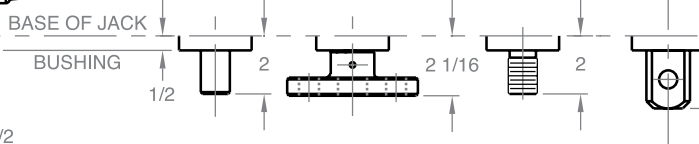

**Inverted keyed**

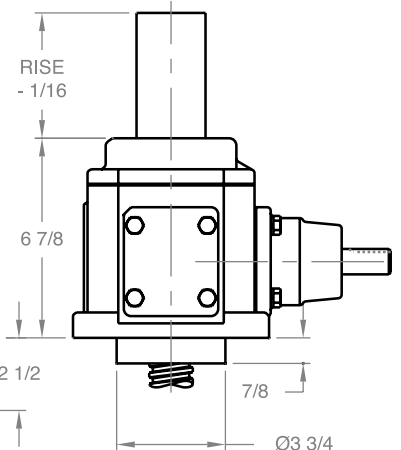

Note: Drawings are artist's conception — not for certification; dimensions are subject to change without notice.

# BEVEL GEAR JACKS

**BG 250 - 2 1/2" SCREW**

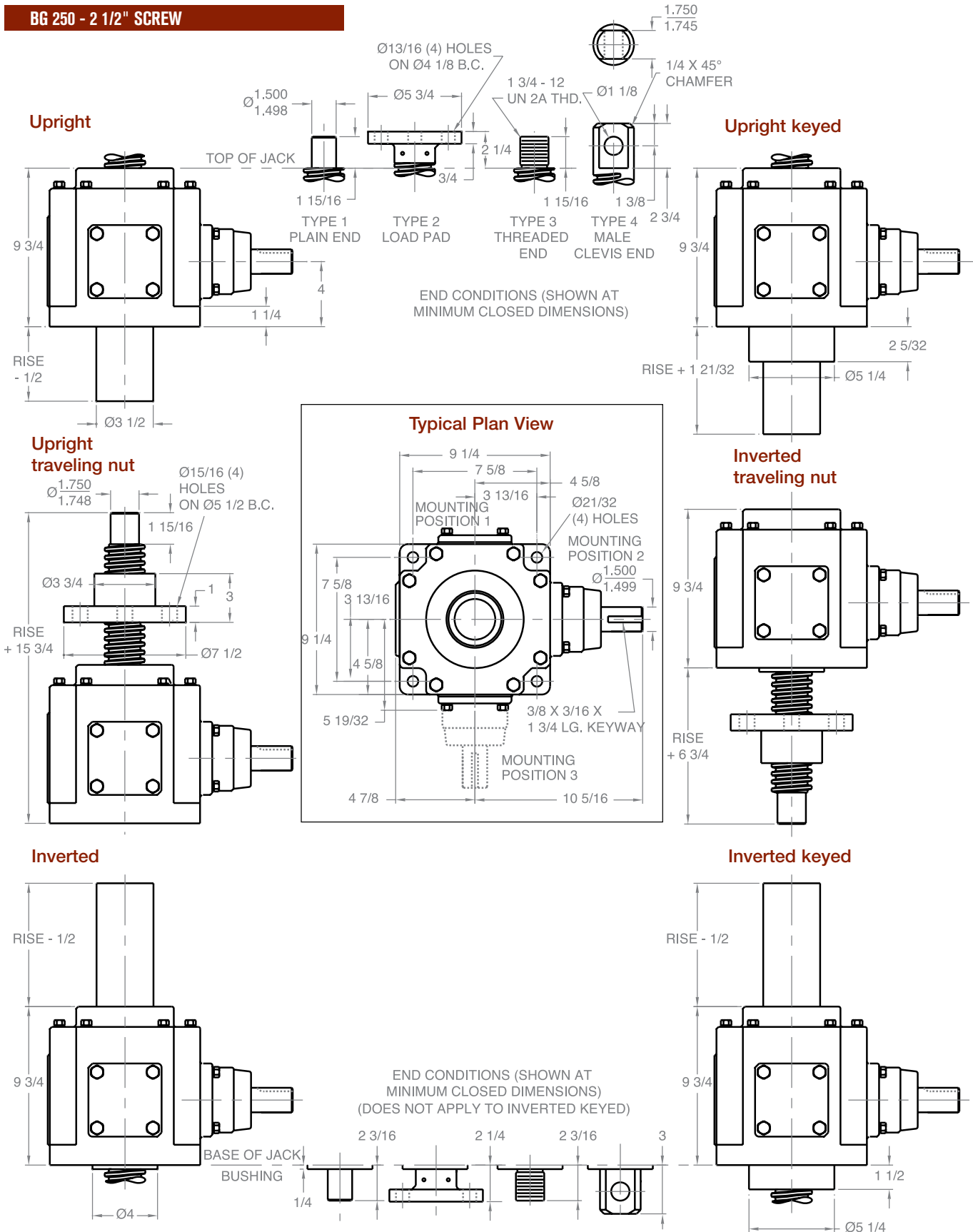

Note: Drawings are artist's conception — not for certification; dimensions are subject to change without notice.

# BEVEL GEAR JACKS

**BG 375 - 3 3/4" SCREW**

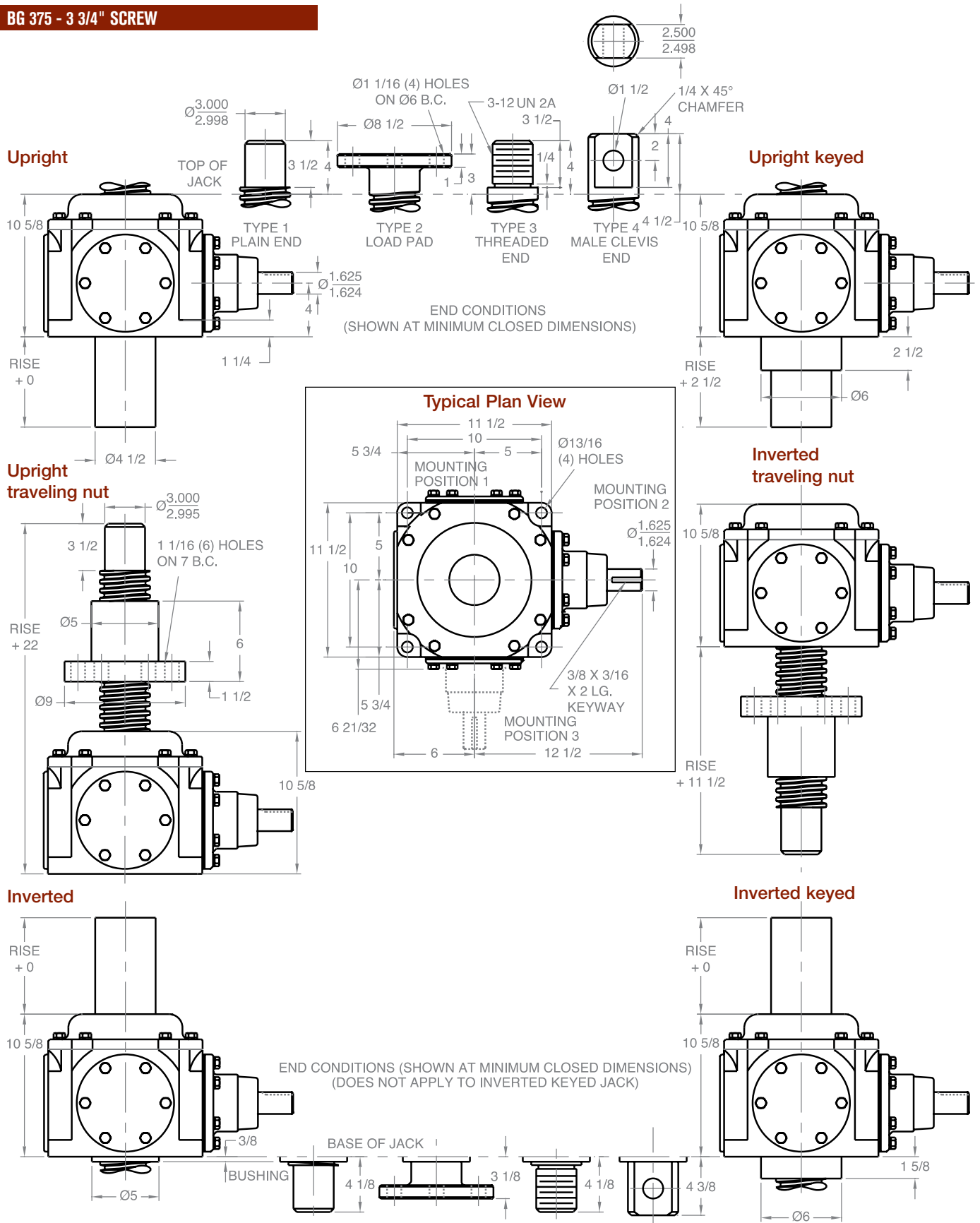

Note: Drawings are artist's conception — not for certification; dimensions are subject to change without notice.

# BEVEL GEAR JACKS

**BG 450 - 4 1/2" SCREW**

## Upright

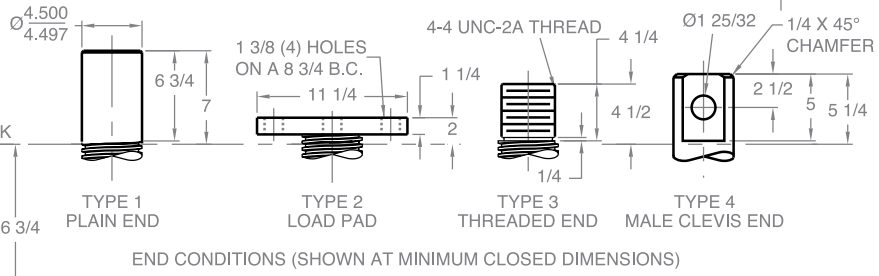
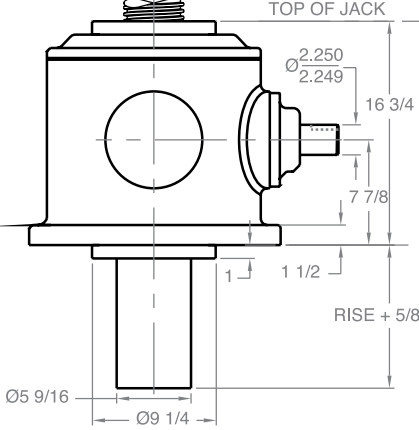

## Upright traveling nut

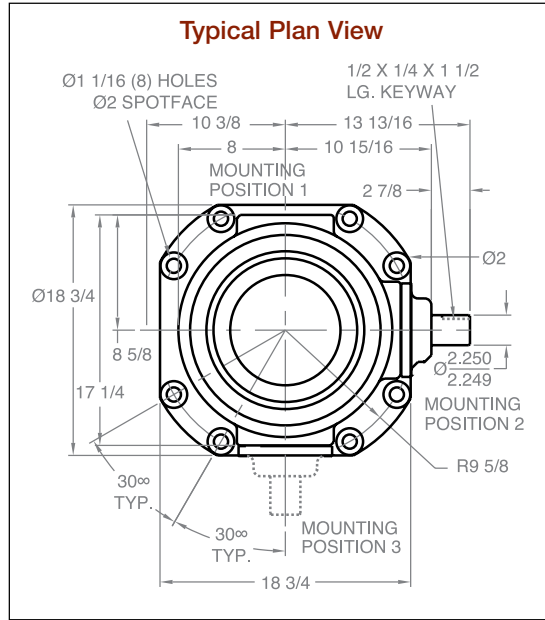
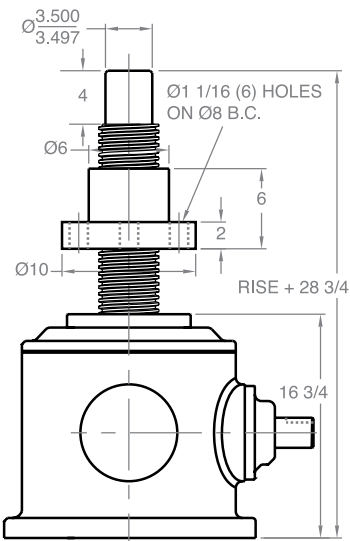

## Inverted traveling nut

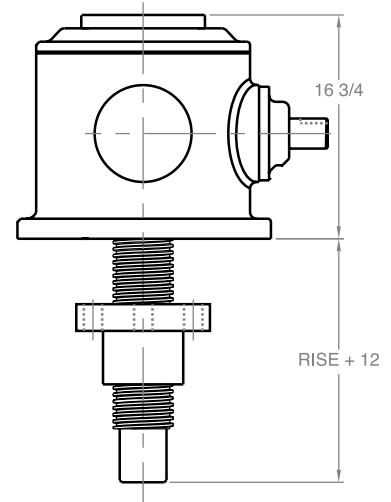

## Inverted

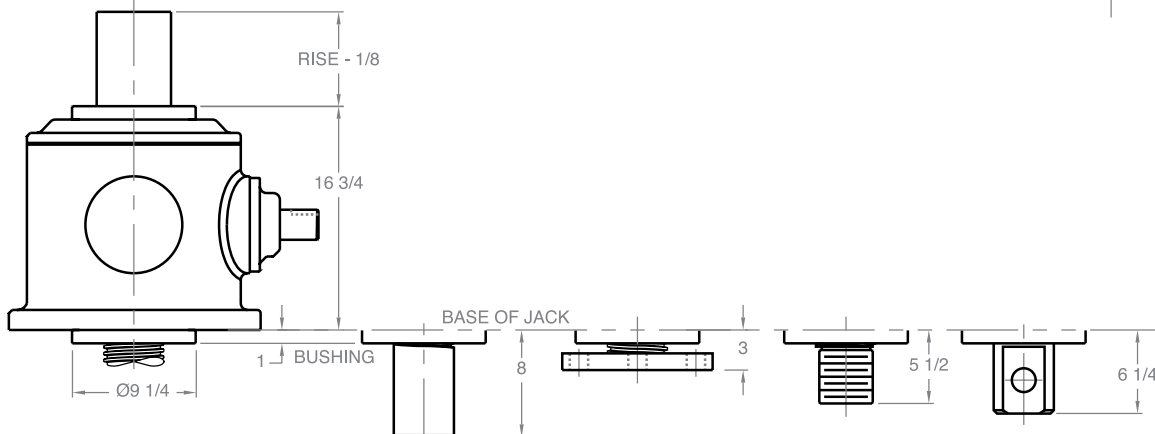

Note: Drawings are artist's conception — not for certification; dimensions are subject to change without notice.

# BEVEL BALL ACTUATORS

To properly size actuators, follow the design tips found on page 161, and refer to the Column Load and Life Expectancy charts (pages 162 and 163). Use JAX® Online software to determine the dynamic capacity of actuators, or contact Joyce.

Joyce high-efficiency bevel ball actuators (BB) are designed for near-continuous duty operation. BB series actuators provide higher speeds and less heat generation than other mechanical actuators and require a brake motor or other external locking device to hold position. They also offer more precise positioning and repeatability than hydraulic cylinders.

Bevel ball actuators are available in 7.5-ton to 100-ton static capacities and are able to attain travel speeds of up to 48 feet per minute. The ball screw and ball nut have a fully predictable J-10 life expectancy. Standard jacks have right hand ball screws. Left hand ball screws are available as an option. A threaded end condition is standard on translating bevel ball actuators; load pad, plain and clevis ends are also available. KFTN designs have a plain turned end condition.

Bevel ball actuators are ideal for either single operation or multi-actuator systems. As many as three output shafts may be specified for mounting motors, limit switches, readout devices and other accessories. See page 195 for an example of a bevel gear jack system. Note that right hand and left hand screw threads are alternated in the layout.

Many options are available including oversized ball bearings, which can be specified to reduce endplay between ball screw and ball nut. All jack designs can be fitted with protective boots.

Joyce can customize bevel ball actuators to meet your requirements.

Joyce offers Bevel Ball Actuators in the following designs:

- Translating
- Keyed for traveling nut (KFTN)

A guide for ordering is on page 160.



# BEVEL BALL ACTUATORS ORDERING INFORMATION

**Instructions:** Select a model number from this chart.



Joyce Bevel Ball Actuators	
BB150	
BB225	
BB300	
BB400	





Evaluate column load (p. 162).  
 Evaluate ball nut life (p. 163).  
 Detailed product information (pp. 164-167).  
 Right hand ball screws standard.



Bevel Ball Actuator Rise
Rise is travel expressed in inches and not the actual screw length.

Screw Stops (p. 10) and Boots (pp. 171-173)
Extending Screw Stops are optional on bevel ball actuators. When specified, the closed height of the jack and protection tube length may be increased.

Sample Part Number: **BB225U3S-12-XXXX-STDX-XXXX-B**

Actuator Configuration	
 U=Upright	 I=Inverted

End Conditions			
 1=T1 (plain end)	 2=T2 (load pad)	 3=T3 (threaded end)	 4=T4 (male clevis)

Actuator Design		
 S=Translating	 Keyed for Non Rotation is not a standard option	 N=Traveling Nut

Encoders (pp. 176-177)	
<b>ENCA</b> =Absolute Encoder 0-10 VDC, programmable	
<b>ENCB</b> =Absolute Encoder 4-20mA, programmable	
<b>ENCC</b> =Absolute Encoder CAN Open	
<b>ENCD</b> =Absolute Encoder SSI	
<b>ENCS</b> =Stainless Steel Incremental Encoder 1024 PPR	
<b>ENCX</b> =Incremental Encoder 200 PPR <b>ENCY</b> =Incremental Encoder 1024 PPR	

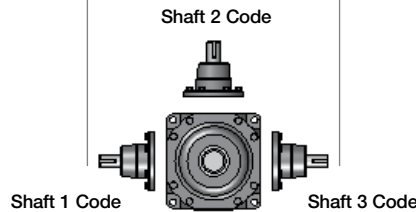









Shaft Codes
Three shaft codes must be specified for each jack. Electronic and mechanical limit switches may be substituted for the shaft code per the tables on this page.
<b>STDX</b> – Standard
<b>XXXX</b> – Input shaft not required
<b>CUST</b> – Custom
When ordering with only one input shaft, it is recommended to order the following configuration: <b>XXXX-STDX-XXXX.</b>

Additional Options*
<b>X</b> =Standard Actuator, no additional options
<b>S</b> =Additional Specification Required (comment as necessary)
<b>Protective Boots</b> pp. 171-173 <b>B</b> =Protective Boot <b>D</b> =Dual Protective Boot
<b>Finishes</b> p. 182 <b>F1</b> =Do not Paint <b>F2</b> =Epoxy Paint <b>F3</b> =Outdoor Paint Process
<b>Ball Screw</b> <b>L</b> =Left Hand Screw
<b>Screw Stops</b> <b>ST0</b> =Extending Stops
* Specify as many options as needed

## Mechanical Limit Switches (p. 174)

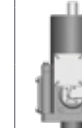
Ordering Example: **LA13**

Models		Number of DPDT Switches (see p. 174)	Available Positions							
Model	Code		1	2	3	4	5	6	7	8
LS7-402	LI	NOTE: Will always be 0 for LS7 models								
LS8-402	LA									
LS8-404	LB									

Note: All BB actuators are available with all mounting positions.



# BEVEL BALL ACTUATORS SPECIFICATIONS AND DESIGN TIPS

Model	Dynamic Capacity	Static Capacity (Lbs)		Screw Dia./ Lead	Bevel Gear Ratio	Pinion Turns for 1" Travel	Pinion Torque (Raising)	Pinion Torque (Holding)	Screw Torque	Actuator Efficiency	Base Weight (Lbs)	Add for each inch of travel
		Upright Assembly Screw in Tension	Upright Assembly Screw in Compression									
BB150	Please use JAX® Online software or contact Joyce	15,000	15,000	1.50/.25	2.69:1	10.77	.022W*	.018W*	.044W*	72.2%	52	0.7
BB225		30,000	30,000	2.25/.50	2.15:1	4.31	.054W*	.044W*	.089W*		200	2.6
BB300		42,500	70,000	3.00/.66	3.52:1	5.34	.044W*	.035W*	.117W*		360	3.2
BB400		200,000	200,000	4.00/1.00	3:1	3.00	.078W*	.063W*	.117W*		740	4.8
Model		Inverted Assembly Screw in Tension	Inverted Assembly Screw in Compression	Screw Dia./ Lead	Bevel Gear Ratio	Pinion Turns for 1" Travel	Pinion Torque (Raising)	Pinion Torque (Holding)	Screw Torque	Actuator Efficiency	Base Weight (Lbs)	Add for each inch of travel
BB150	15,000	15,000	1.50/.25	2.69:1	10.77	.022W*	.018W*	.044W*	72.2%	52	0.7	
BB225	30,000	30,000	2.25/.50	2.15:1	4.31	.054W*	.044W*	.089W*		200	2.6	
BB300	70,000	42,500	3.00/.66	3.52:1	5.34	.044W*	.035W*	.117W*		360	3.2	
BB400	200,000	200,000	4.00/1.00	3:1	3.00	.078W*	.063W*	.117W*		740	4.8	

**Important Note:** Bevel Ball Actuators are not self-locking. Brake motors or external locking systems are required.

\*W: Load in Pounds.

**Pinion Torque (raising):** The torque required to continuously raise a given load.

**Pinion Torque (holding):** The torque required to hold a given static load in position.

**Screw Torque:** The torque required to resist screw rotation (translating design) and traveling nut rotation (KFTN design).

**Lead:** The distance traveled axially in one rotation of the lifting screw.

**Pitch:** The distance from a point on the screw thread to a corresponding point on the next thread, measured axially.

## Design Tips

- Determine the load to each actuator.
- Determine the orientation and type of load; for instance, from the chart above it may be an upright compression load or an inverted compression load.
- Jax® software can be used to determine the following:
  - The allowable static compression load for a given rise (or use Column Loading Chart on page 162)
  - The allowable dynamic load for a given rise
  - Ball nut life (or use Life Expectancy of the ball screw chart on page 163)
  - System horsepower and torque – also see item #4
- When a direct motor drive is used in a system, consideration must be given to the input starting torque requirements and the motor horsepower will need to be increased accordingly (JAX® software may require additional scrutiny). Contact sales@joycedayton.com for assistance.
- When selecting bevel ball actuators for an interconnected row or system (p. 195), careful attention must be given to the input and output shaft rotations. For example, if the input shaft rotation on the first actuator is clockwise, the output shaft(s) on that same actuator will rotate counter-clockwise. To insure all actuators raise and lower in unison, alternating actuators must be specified with right and left hand ball screw threads. For example, if you need five actuators interconnected in a straight line and the first actuator is right hand, the third and fifth actuator will also need to be ordered as right hand and the second and fourth actuator will need to be ordered as left hand. Bevel ball actuators are supplied standard with right hand ball screws. To order the left hand ball screw option, add an "L" to the end of your bevel ball actuator part number as shown on page 160.
- Bevel ball actuators are not self-locking. They will lower under load. A brake motor or other external locking system is required.
- Bevel ball actuators are furnished with one input shaft (pinion) in position #2. Actuators may be ordered with up to three input shafts located at any combination of positions # 1, 2, or 3.
- Translating bevel ball actuators are designed for grease lubrication. The upper bearing is grease lubricated through a fitting on top of the jack. Light oil must be applied directly to the lifting screw.
- Typically actuators are mounted upright with the jack base plate parallel to the horizon. If the base plate is oriented any other way, contact Joyce for lubrication and other instructions.

# BEVEL BALL ACTUATORS COLUMN LOADING

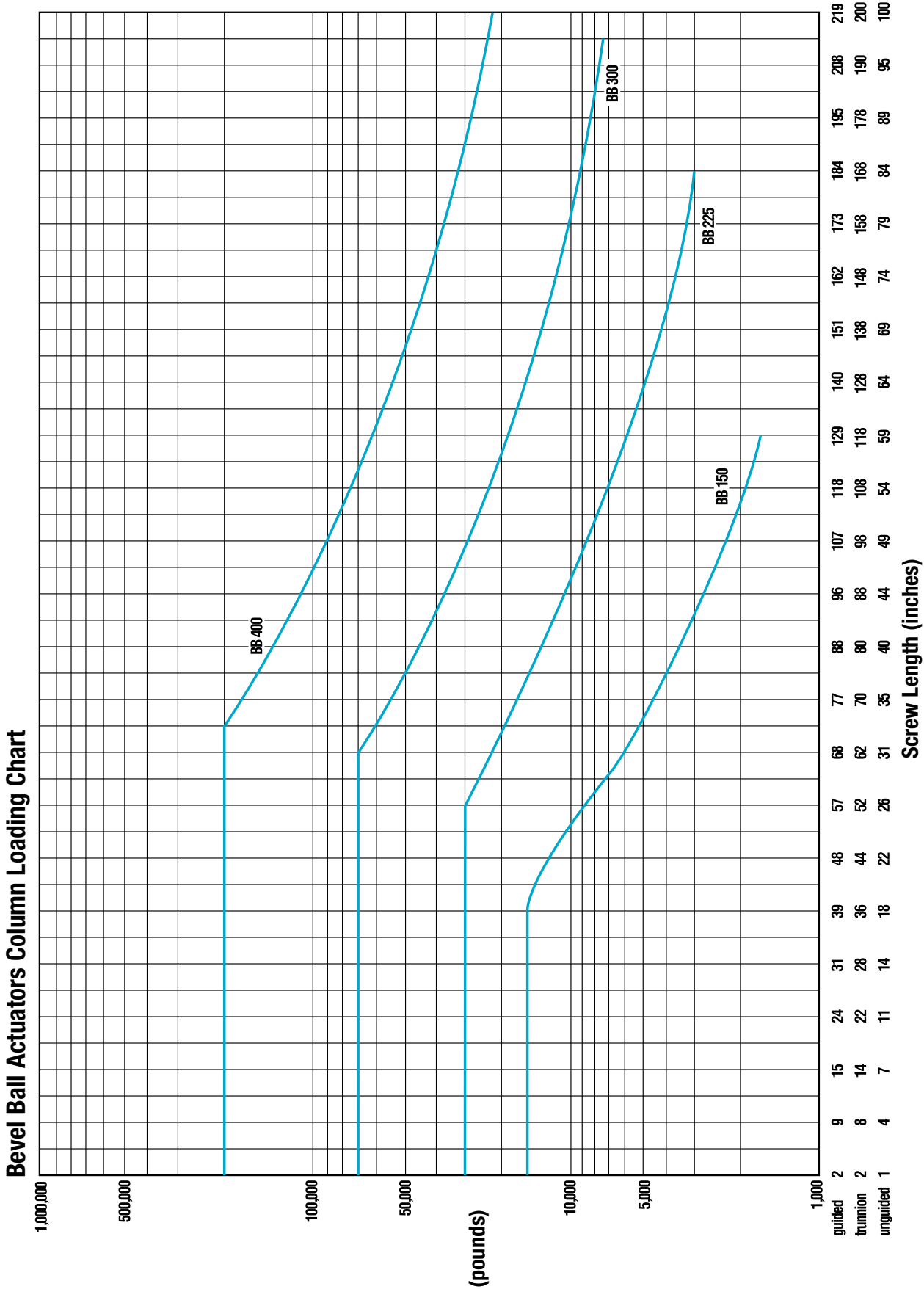

This chart includes a 2:1 Factor-of-Safety based on the Euler-Johnson equation for column loading (Oberg, Erik et al: Machinery's Handbook, 24th Edition. c. 1992 Industrial Press Inc.)  
 The horizontal portion of each line represents the jack's maximum static capacity.

# BEVEL BALL ACTUATORS LIFE EXPECTANCY

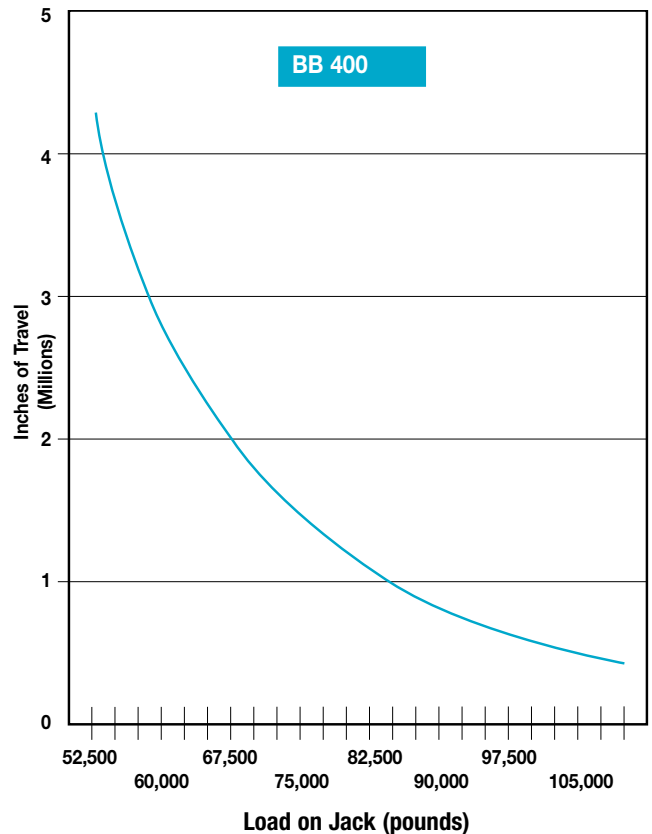
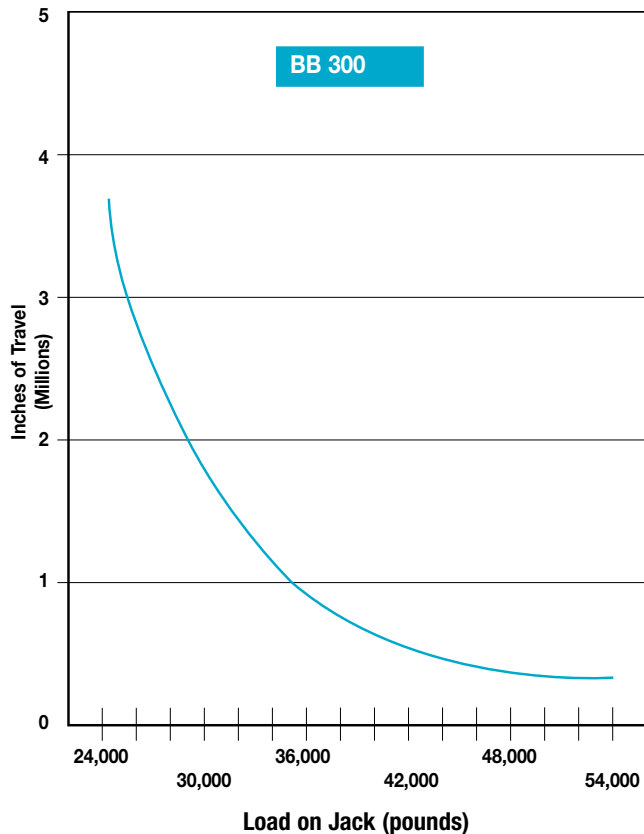
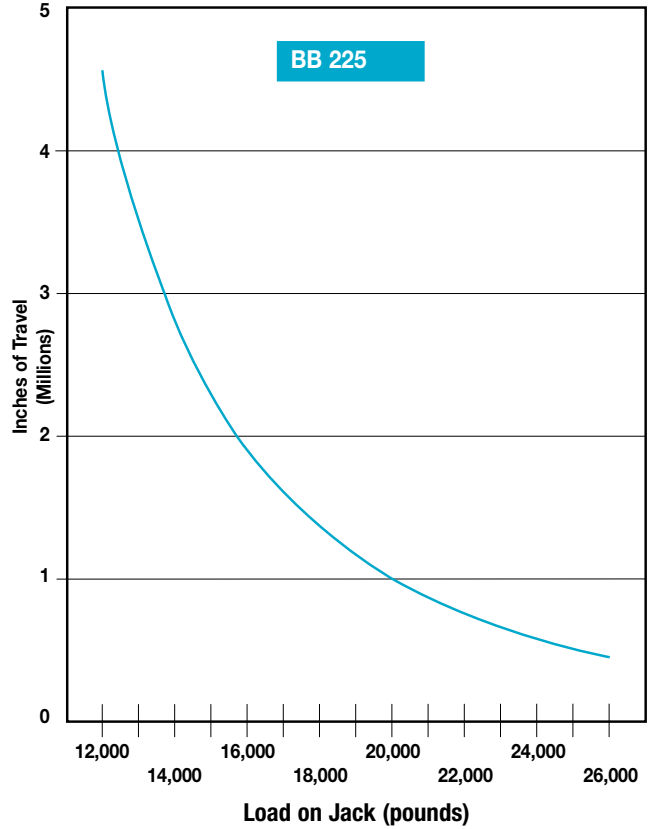
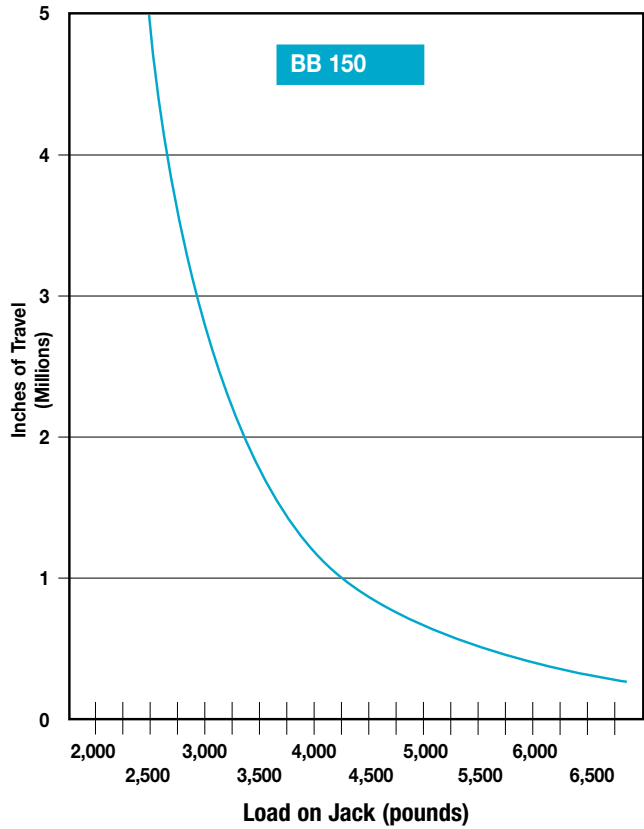

# BEVEL BALL ACTUATORS

## BB 150 - 1 1/2" SCREW

### Upright

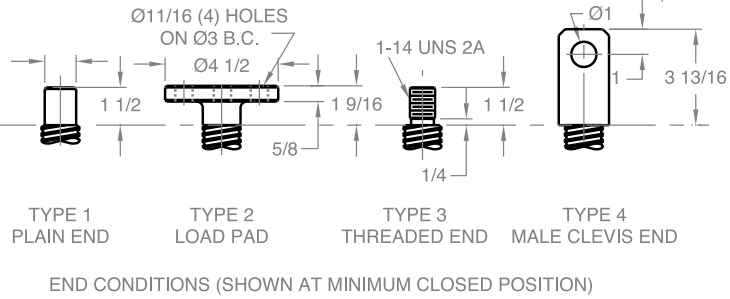
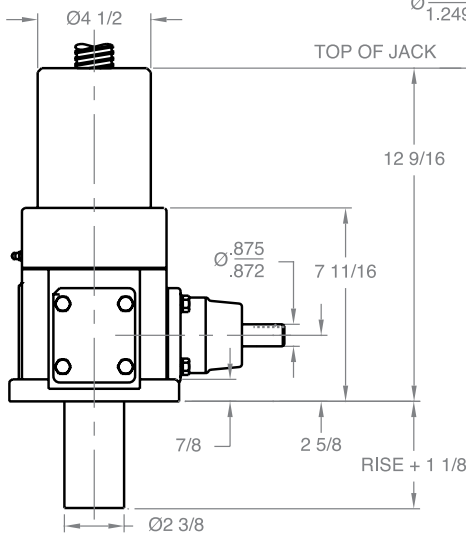

### Upright traveling nut

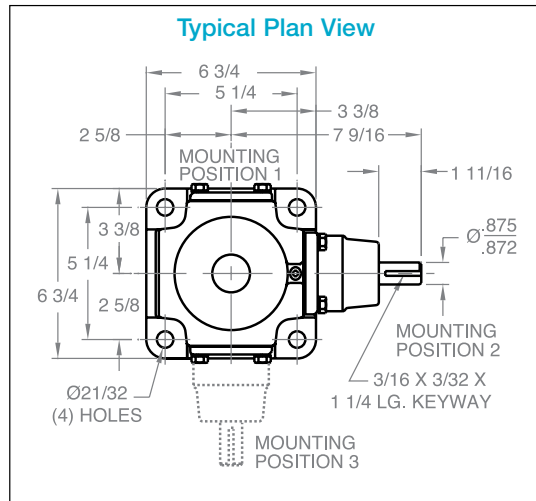
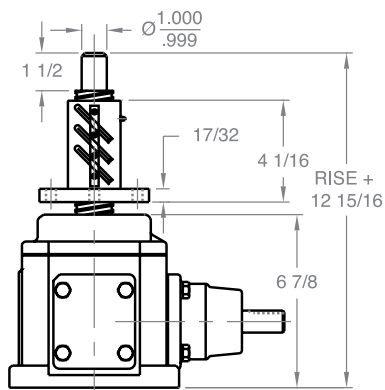

### Inverted traveling nut

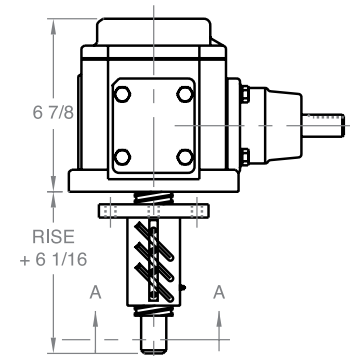

### Inverted

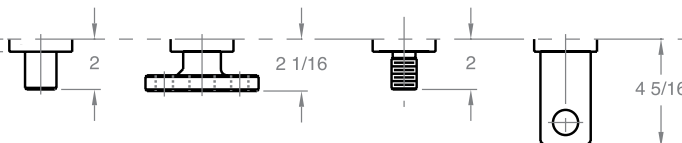
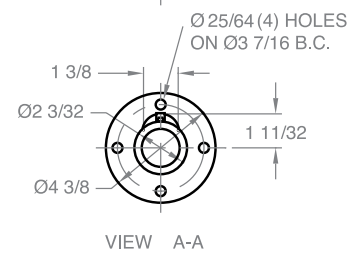
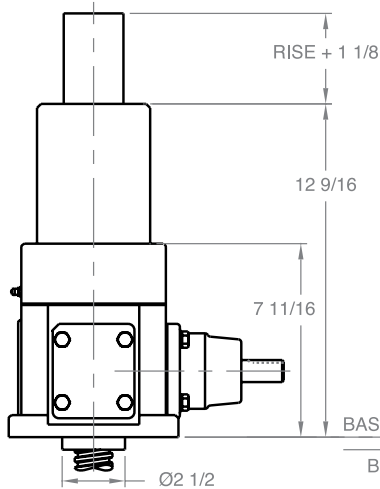

Note: Drawings are artist's conception — not for certification; dimensions are subject to change without notice.

# BEVEL BALL ACTUATORS

BB 225 - 2 1/4" SCREW

## Upright

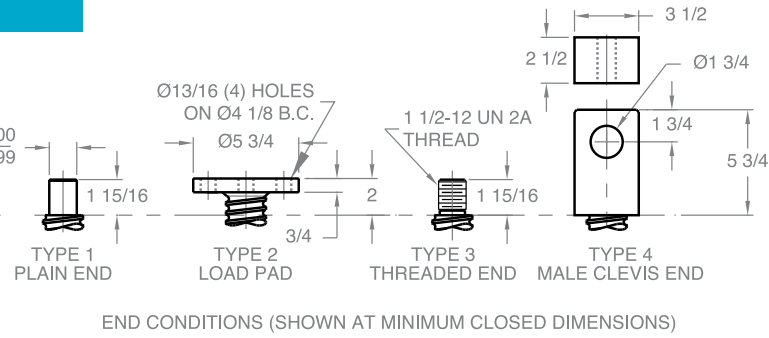
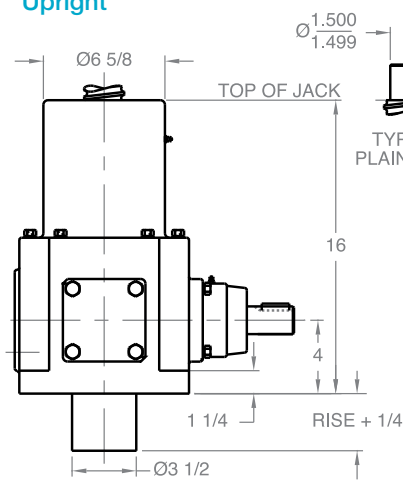

## Upright traveling nut

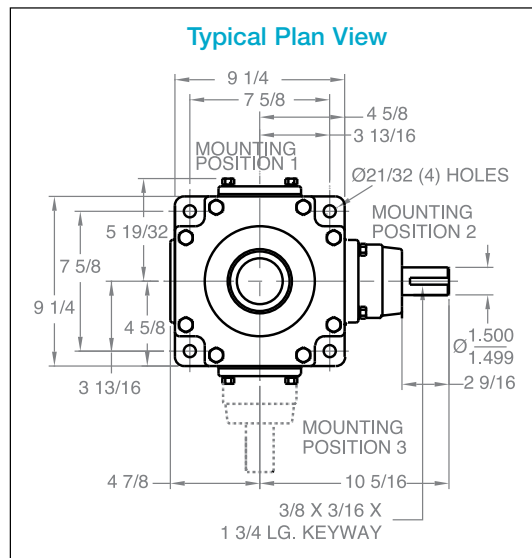
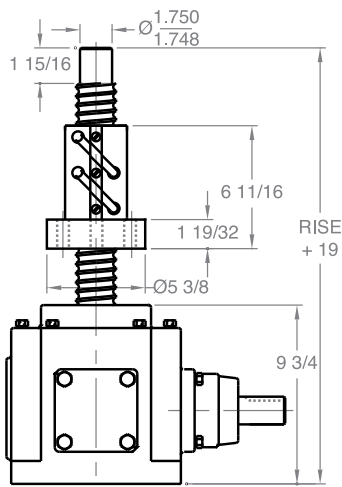

## Inverted traveling nut

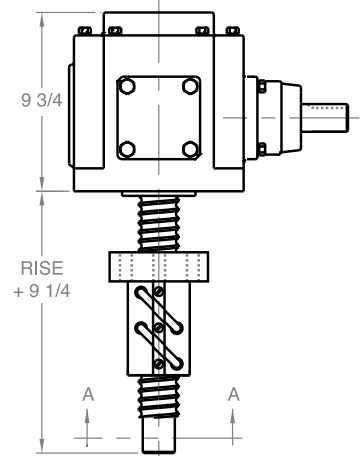

## Inverted

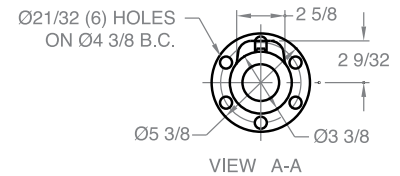
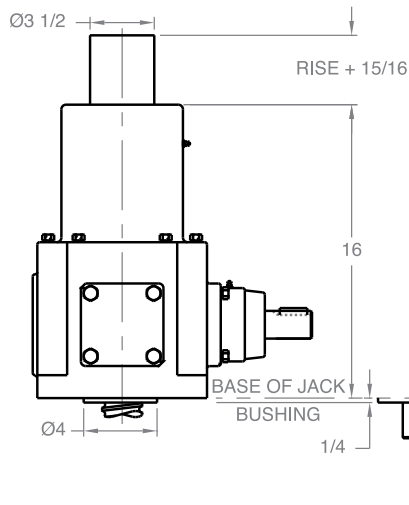

Note: Drawings are artist's conception — not for certification; dimensions are subject to change without notice.

# BEVEL BALL ACTUATORS

BB 300 - 3" SCREW

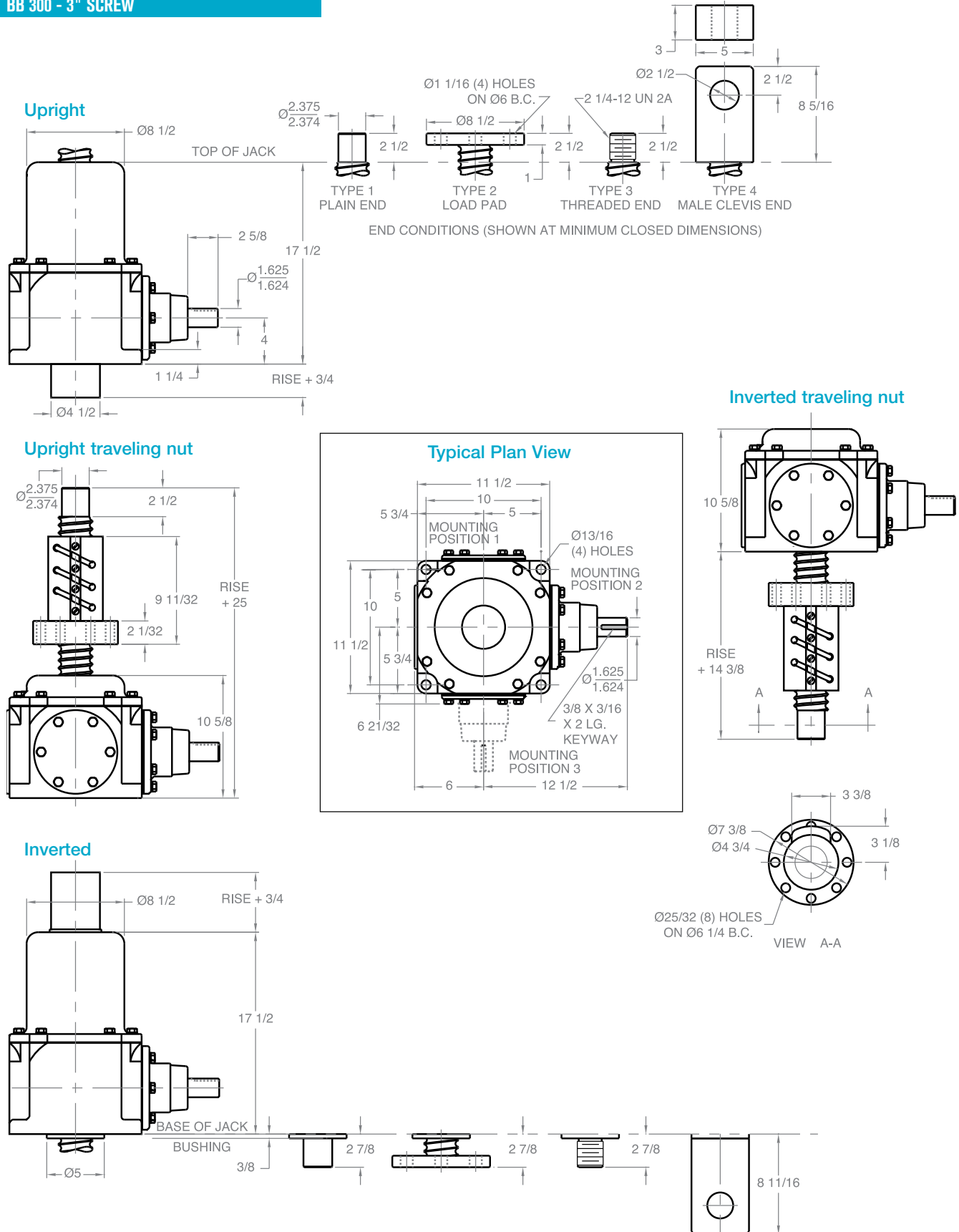

Note: Drawings are artist's conception — not for certification; dimensions are subject to change without notice.

# BEVEL BALL ACTUATORS

BB 400 - 4" SCREW

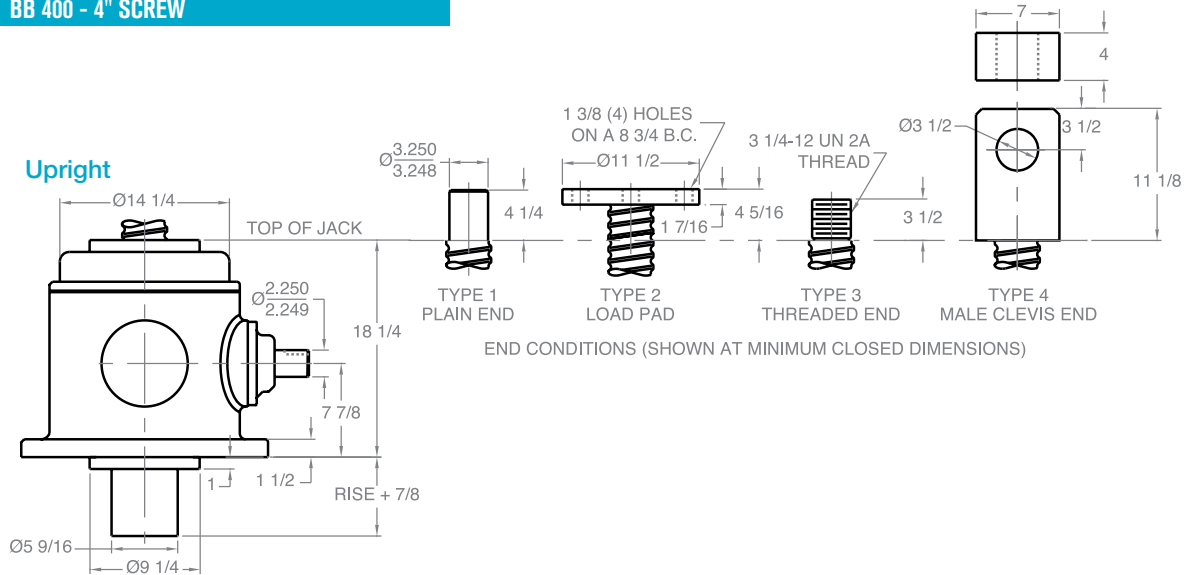

**Upright traveling nut**

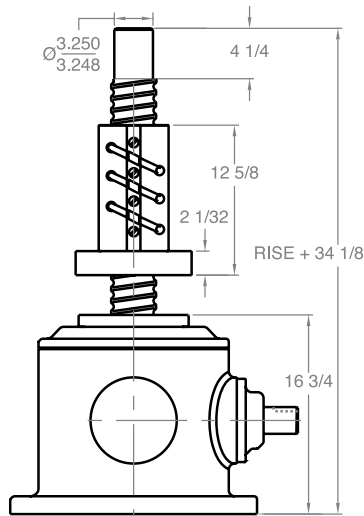

**Typical Plan View**

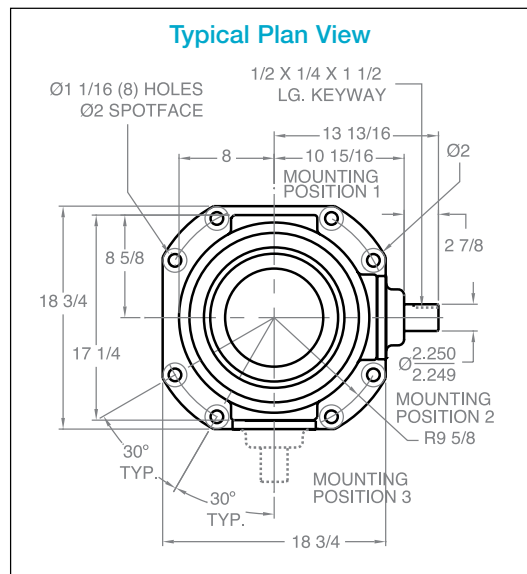

**Inverted traveling nut**

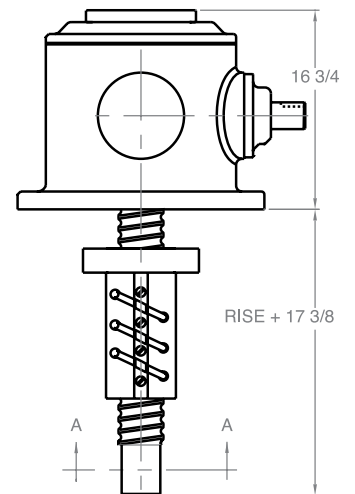

**Inverted**

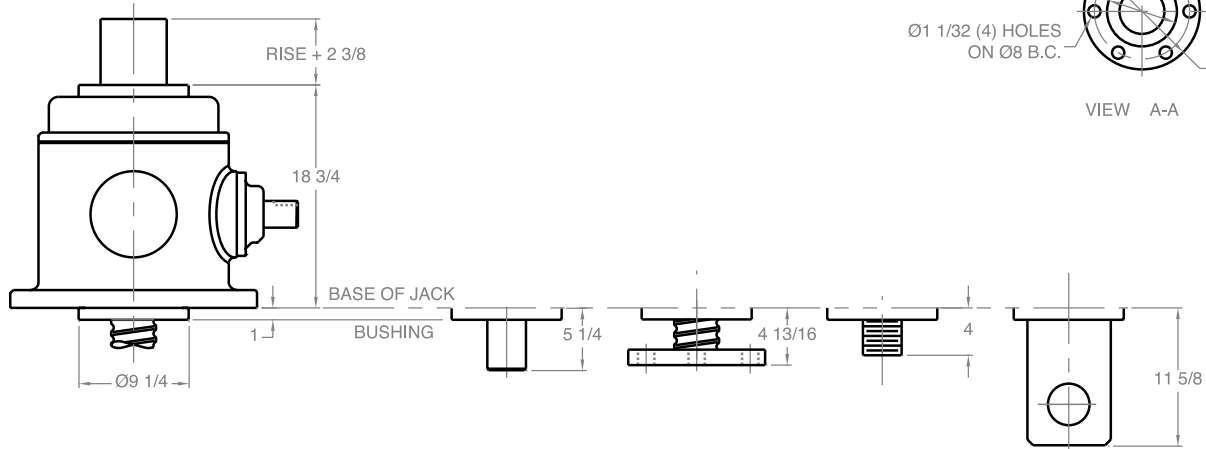

Note: Drawings are artist's conception — not for certification; dimensions are subject to change without notice.

Choose the Joyce options, accessories and motor controls needed to complete your jack system.

We offer everything from protective boots and anti-backlash devices to special materials and finishes. The information needed to complete a system can be found on the pages that follow.

Select components for single- or multiple-jack systems. Choose miter boxes, pillow block supports, shafting and couplings.

Finish the system with a standard motor control, or let us know your requirements. We offer an extensive line of motor starters as well as programmable controls for synchronized systems and leveling systems.

Joyce has been designing systems for decades. Our experienced application engineers can help you put it all together. Contact us today.

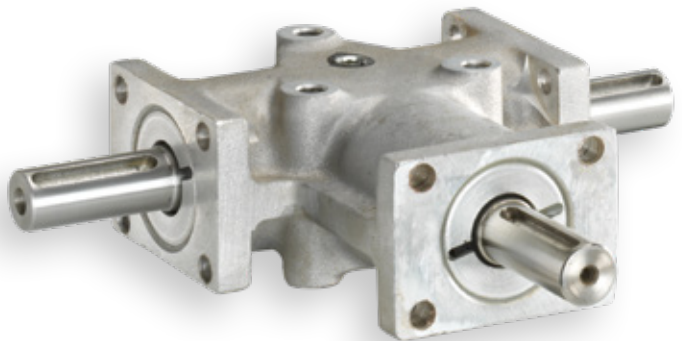



# OPTIONS, ACCESSORIES AND CONTROLS

## Options:

Boots 170-173  
Limit Switches 174  
Potentiometers 175  
Encoders 176-177  
Servo Motor Mounts 178  
Motor Mounts and Stock Motors 179  
Hand Wheels and Counters 180  
Anti-Backlash Devices 181  
Special Finishes 182  
Trunnion Mounts 183

## Accessories:

Pillow Blocks and Flange Blocks 184  
Miter Gear Boxes 185-187  
Couplings 188-189  
Shafting 190-191

## Controls:

Motor Starters 192  
Programmable Controls 193  
Linear Actuator Controls 194

## Systems:

Common Arrangements 195



# OPTIONS BOOTS FOR MACHINE SCREW JACKS

## For Translating and Keyed Design Machine Screw Jacks

When boots are included on the Joyce jacks or actuators, Joyce sizes them as part of our service to you.

Adding boots to most jacks increases their retracted (closed) height, "A" or "B". The diagrams and chart below are provided as a reference to help illustrate how the addition of standard boots to jacks increases the closed height of those jacks.

The retracted (closed) height, "A" or "B", is based on the jack capacity and it changes based on the length of travel (rise), and end condition of the lifting screw. For instance, an upright 2-ton jack with a T3 end condition and 12 inches of rise will have a greater closed dimension than the same 2-ton jack with just 3 inches of rise.

Standard boot outside diameter, "C", and collar diameter at the base of the jack, "D" are listed in the chart below for reference.

Although Joyce provides the stainless steel clamps needed to secure all boots in place, customers must provide a mounting ring of the standard diameter "D" to mount the boots on inverted jacks.

When you use Joyce 2D/3D online software to specify jacks with boots, the drawings will more accurately depict the added screw length needed to accommodate the boot. However, the actual boot will not be shown on the drawing.

Common Boot Options:

- Zippered boots
- Boots for high temperatures

Contact Joyce for more information about these and other custom boot applications or boots for Bevel Gear Jacks.

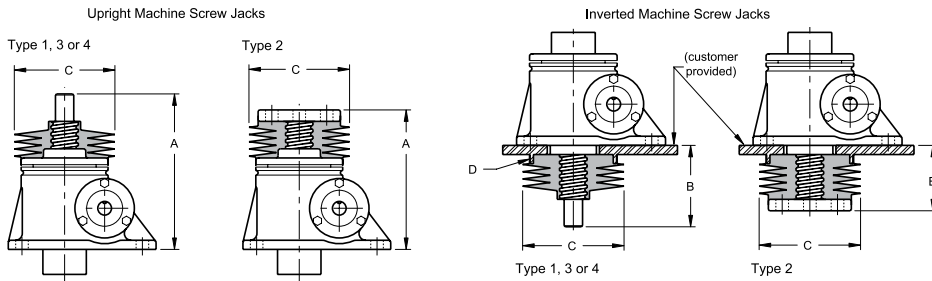

Jack Capacity	A - Closed Height for Upright Jack				Max. Travel Without Increasing Closed Height - Upright Type 2**	B - Closed Height for Inverted Jack				C O.D. of Boot	D Collar Diameter
	Type 1*	Type 2	Type 3*	Type 4*		Type 1*	Type 2*	Type 3*	Type 4*		
250/500 Lb.	4 1/2	4	4 1/2	3 3/4	12	2 3/4	1 5/8	2 3/4	2	3.5	2 5/16
1,000 Lb.	4	4	4	4	12	3	2	3	2 1/4	3.5	2 5/16
1 Ton	5 3/8	4 1/2	5 3/8	5 3/8	9	2 1/2	1 15/16	2 1/2	2 1/2	5	2 3/4
2 Ton	6	5 5/16	6	6 1/4	3	2 7/8	2 1/16	2 7/8	3 3/16	5	3 3/4
3 Ton	5 15/16	5 1/4	5 15/16	6 3/4	0	2 5/8	1 15/16	2 5/8	3 1/2	5	3 3/4
5 Ton	7 3/4	7 1/16	7 3/4	8 1/4	6	3 7/8	2 11/16	3 7/8	4 3/8	5 1/2	4 3/4
10 Ton	8	7 1/4	8	8 11/16	9	4	2 1/2	4	4 11/16	6 1/2	5 3/4
15 Ton	8 3/4	8	8 3/4	9 7/16	9	4	2 1/2	4	4 11/16	6 1/2	5 3/4
20 Ton	9 15/16	9 1/4	9 15/16	10 3/4	9	3 15/16	2 1/2	3 15/16	4 3/4	6 1/2	6
25 Ton	11 3/8	11	12 1/4	12 3/4	9	4 1/16	2 7/8	4 15/16	5 7/16	8	7 1/2
30 Ton	11 15/16	11 1/2	11 3/16	17 1/16	21	4 15/16	4 1/8	4 3/16	9 11/16	8	8 1/4
35 Ton	13 5/8	12	13 5/8	13 5/8	0	6 11/16	5 1/16	6 11/16	6 11/16	10	8 1/2
50 Ton	18	14 3/8	18	18	0	10 5/8	7	8 3/8	9 1/8	13	11 5/8
75 Ton	20 1/2	16 1/2	20 1/2	20 1/2	0	9 7/8	5 13/16	7 3/4	7 7/8	13	13 1/2
100 Ton	20 1/4	19	20 1/4	21 1/4	0	9 7/8	6 7/16	8 3/8	8 7/8	14 1/2	15

150-ton and 250-ton dimensions supplied upon request.

\* Closed height given must be increased by about 0.071" for each 1" of travel.

\*\* Upright Type 2 closed height must be increased by about 0.071" for each 1" over the maximum given.

A and B dimensions generally increase when boots are added to jacks.

Note: Drawings are artist's conception — not for certification; dimensions are subject to change without notice.

# OPTIONS BOOTS FOR BALL SCREW JACKS

## For Translating Design Ball Screw Jacks

When boots are included on Joyce jacks or actuators, Joyce sizes them as part of our service to you.

Adding boots to most jacks will increase their retracted (closed) height, "A" or "B". The diagrams and chart below are provided as a reference to help you understand how the addition of standard boots increases the closed height of those jacks.

The retracted (closed) height, "A", or "B", is based on the jack capacity and it changes based on the length of travel (rise), and end condition of the lifting screw. For instance, an upright 2-ton jack with a T3 end condition and 12 inches of rise will have a greater closed dimension than the same 2-ton jack with just 3 inches of rise. Standard boot outside diameter, "C", and collar diameter at the base of the jack, "D" are listed in the chart below for reference.

Although Joyce provides the stainless steel clamps needed to secure all boots in place, customers must provide a mounting ring of the standard diameter "D" to mount the boots on inverted jacks.

When you use Joyce 2D/3D online software to specify jacks with boots the drawings will accurately depict the added screw length needed to accommodate the boot, however the actual boot will not be shown on the drawing.

Common Boot Options:

- Zippered boots • Boots for high temperatures • Boots for corrosive atmospheres

Contact Joyce for more information about these and other custom boot applications or boots for Bevel Gear Jacks.

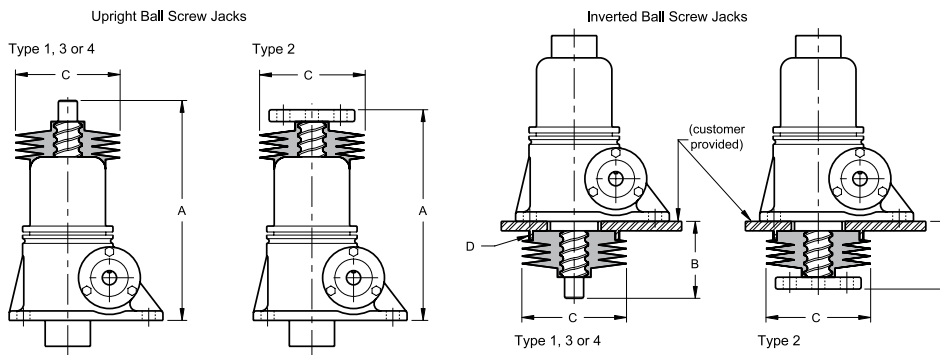

△ The closed height of Type 4 jacks remains the same up to the maximum travel given in the chart below.

Jack Capacity	A - Closed Height for Upright Jack				▲ - Type 4**	B - Closed Height for Inverted Jack				▲ - Type 4**	C O.D. of Boot	D O.D. of Collar
	Type 1*	Type 2*	Type 3*	Type 4*		Type 1*	Type 2*	Type 3*	Type 4*			
1 Ton WBL	6 7/16	6 1/4	6 7/16	7 1/4	6	2 5/8	2 1/4	2 5/8	2 7/8	0	5	2 3/4
1 Ton WB	7 7/16	7 1/4	7 7/16	8 1/4	9	2 5/8	2 1/4	2 5/8	2 7/8	0	5	2 3/4
2 Ton	8 3/8	7 3/4	8 3/8	9 5/8	12	3 1/4	2 9/16	3 1/4	3 5/8	0	5	2 3/4
5 Ton	10 1/2	11	10 1/2	13 3/8	18	3 13/16	3 5/16	3 13/16	5 3/16	0	5 1/2	4 3/4
10 Ton WBL/HWBL	11 1/4	10 5/16	11 1/4	13 1/16	15	4 7/16	3 7/16	4 7/16	5 3/16	0	6 1/2	5 3/4
10 Ton WB/HWB	15	14 1/2	15	16 3/4	18	4 15/16	3 3/4	4 15/16	5 1/2	0	6 1/2	5 3/4
20 Ton	17 3/16	16 5/8	17 3/16	20 5/16	27	4 3/4	3 7/16	4 3/4	6 1/2	9	6 1/2	6
30 Ton	23 1/4	22 9/16	23 1/4	28 5/16	42	6 1/4	4	6 1/4	10	24	8	8 1/4
50 Ton	27 3/16	26 7/16	27 3/16	32 1/2	45	6 11/16	4 15/16	6 11/16	10 1/4	21	13	11 5/8

\* Closed height given must be increased by about 0.071" for each 1" of travel.

\*\* Type 4 closed height must be increased by about 0.071" for each 1" over the maximum given.

A and B dimensions generally increase when boots are added to jacks.

Note: Drawings are artist's conception — not for certification; dimensions are subject to change without notice.

# OPTIONS BOOTS FOR KFTN JACKS

## For Traveling Nut Design Machine and Ball Screw Jacks

Adding single or dual boots to cover the fixed-length rotating screw on KFTN jacks usually increases the base-to-end of screw dimension due to boot stack up\*. Other factors that affect boot specification include:

- Jack orientation – Upright or inverted
- Travel distance and maximum height of jack with boots (Base-to-end of screw)
- Traveling Nut (TN) orientation – TN mounted toward the jack or away from the jack
- Position and thickness of the load – Mounted above or below the flange
- Choice of dual boots, single upper boot, or single lower boot

The chart below lists standard boot diameter dimensions based on jack capacity. Working from this reference and input provided by customers about their applications, Joyce customizes boots to meet specific requirements. Please complete the worksheet on page 173 to help us understand your requirements more fully.

Although Joyce provides the stainless steel clamps needed to secure all boots in place, customers must provide mounting rings to mount boots to their structures. These customer provided mounting diameters must also be communicated to Joyce to ensure that boot collars are compatibly sized.

Common bellows boot options:

- Zippered boots • Boots for high temperatures • Boots for harsh environments

Contact Joyce for more information about these and other custom boot applications or boots for Bevel Gear® jacks.

\*Boot stack up is the space required to accommodate retracted bellows boots. It can be estimated by multiplying the maximum amount of travel by 0.071". If the KFTN jack has dual boots the stack up of both boots must be considered. Contact Joyce for additional information.

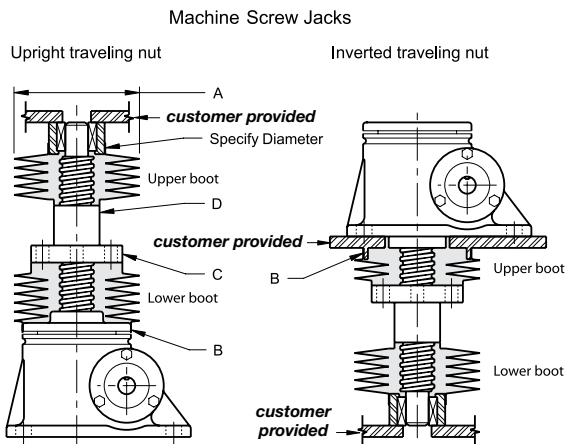

See selection guide worksheet on page 173

Jack Capacity	A O.D. of Boot	B Collar Diameter	C - Flange Collar Diameter		D - Nut Collar Diameter Machine Screw Jacks Only**
			ACME Nut	Ball Nut	
250/500 Lb.	3.5	2 5/16	2 1/4		1
1,000 Lb.	3.5	2 5/16	2 1/4		1
1 Ton	5	2 3/4	3 1/4	2 5/8	1 1/2
2 Ton	5	3 3/4	3 1/4	3 1/4	1 1/2
3 Ton	5 1/2	3 3/4	3 1/4		2
5 Ton	5 1/2	4 3/4	4	4 15/16	2
10 Ton	6 1/2	5 3/4	6	5 3/8	3
15 Ton	6 1/2	5 3/4	6 1/2		3 1/2
20 Ton	6 1/2	6	7 1/2	5 3/8	3 3/4
25 Ton	8	7 1/2	8 1/2		4 1/2
30 Ton	8	8 1/4	7 3/8	7 3/8	4 1/2
35 Ton	10	8 1/2	9		5
50 Ton	10	11 5/8	10	9 3/4	6
75 Ton	13	13 1/2	12		7
100 Ton	14 1/2	15	12 3/4		8

\*\*Boot collars do not fit small end of ball nuts.

Note: Drawings are artist's conception — not for certification; dimensions are subject to change without notice.

# SELECTION GUIDE WORKSHEET BOOTS FOR KFTN JACKS

Name \_\_\_\_\_ Title \_\_\_\_\_  
 Company \_\_\_\_\_ Project \_\_\_\_\_  
 Address \_\_\_\_\_  
 Phone \_\_\_\_\_ Fax \_\_\_\_\_ Email \_\_\_\_\_

Sizing boots for KFTN jacks requires additional input because many mounting configurations are possible. This worksheet is designed to help define and communicate your boot requirements. Complete the form below and submit to [sales@joycedayton.com](mailto:sales@joycedayton.com) along with a sketch of your application.

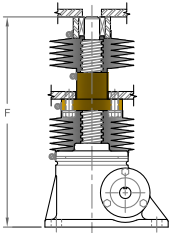
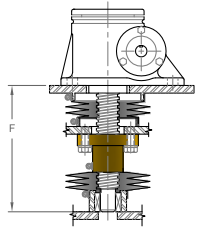
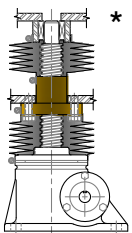
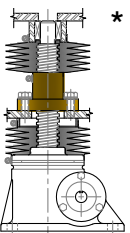
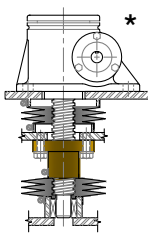
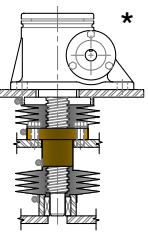
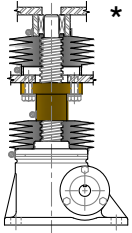
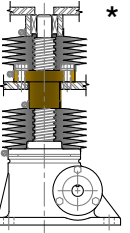
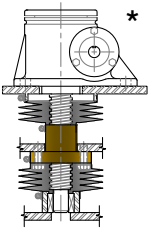
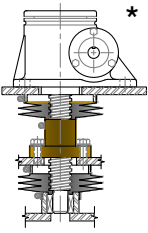
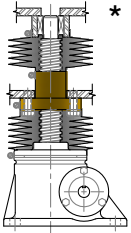
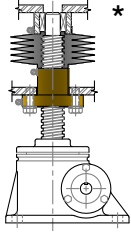
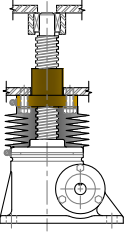
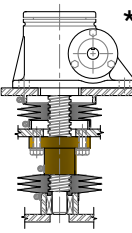
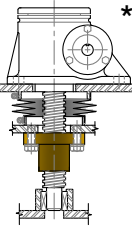
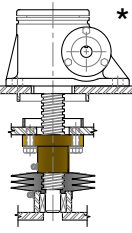
Upright Jack			Inverted Jack		
					
Travel Distance _____ (F) Base-to-end of screw dimension _____			Travel Distance _____ (F) Base-to-end of screw dimension _____		
Choose the image that best represents your application					
 <input type="checkbox"/> Flange toward jack Load above	 <input type="checkbox"/> Flange toward jack Load below	 <input type="checkbox"/> Flange toward jack Load above	 <input type="checkbox"/> Flange toward jack Load below	 <input type="checkbox"/> Flange away from jack Load above	 <input type="checkbox"/> Flange away from jack Load below
 <input type="checkbox"/> Flange away from jack Load above	 <input type="checkbox"/> Flange away from jack Load below	 <input type="checkbox"/> Dual boot	 <input type="checkbox"/> Upper boot	 <input type="checkbox"/> Lower boot	 <input type="checkbox"/> Dual boot
 <input type="checkbox"/> Upper boot	 <input type="checkbox"/> Lower boot				

\*Some customer provided dimensions are required from diagram on page 172.

# OPTIONS LIMIT SWITCHES

Rugged Joyce limit switches allow you to set precise travel limits on Joyce jacks and actuators. They are also ideal in any application where rotary motion of a machine component can be used to indicate linear motion of another part. They are compatible with 2-ton through 150-ton jacks, electric cylinders, and integrated actuators.

## LS7 Limit Switch



The LS7 limit switch has two Single-Pole, Double-Throw (SPDT) switch contacts. This switch offers a NEMA 4 rated enclosure which is rated for dust, rain and hose-directed water. To set switches, first remove the cover plate and "L" bracket, then manually rotate the cams to desired positions. This switch is also compatible with integrated actuators.

## LS8 Limit Switch



The LS8 limit switch is best suited for general-purpose applications requiring up to four switch contacts for operating motors, lights and other accessories. It is available in two models: the LS8 402 (two-switch model) and the LS8 404 (four-switch model). Both LS8 models offer a NEMA 4 rated enclosure which is rated for dust, rain and hose directed water. To set the limit switches simply loosen a cam detent screw and rotate the switch trip cam to the desired position.

Note: "How to" videos can be found at [joycedayton.com](http://joycedayton.com).



Shaft Detail

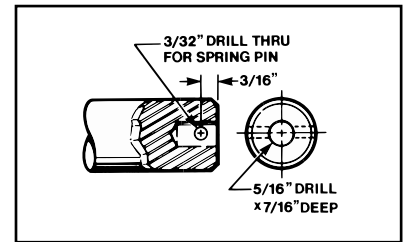

Dimensions															
Type	A	B	C	D	E	F	G	H BG150 BB150	H BG250 BB225	H BG375 BB300	H BG450 BB400	J	K	M	N
LS7 402	3.81	6.13	1.75	5.44	5.00	5.63	1/2 NPT	7.63	9.00	10.13	15.22	7.0	3.28	3.88	2.63
LS8 402	5.50	6.62	2.00	6.75	5.25	6.25	3/4 NPT	7.88	9.25	10.38	15.47	7.62	3.53	5.25	2.46
LS8 404	6.50	8.38	2.00	8.50	6.25	8.25	1 NPT	8.62	10.00	11.19	16.47	9.62	4.53	5.25	2.46

LS8 (400 Series) Switch Combination Chart					
Switch Quantity	Single Pole Double Throw (SPDT)				
	0	1	2	3	4
D.	0		402		404
P.	1	402		404	
D.	2	402		404	
T.	3		404		
	4	404			

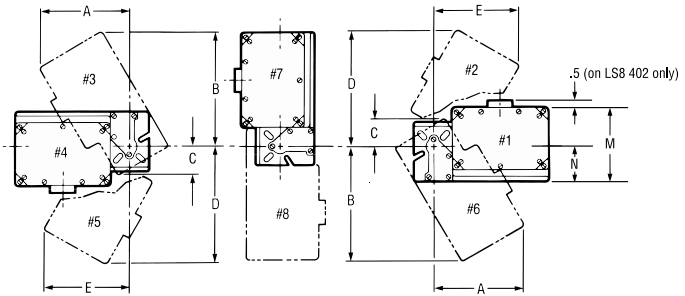

Rotation positions shown looking into end of shaft.

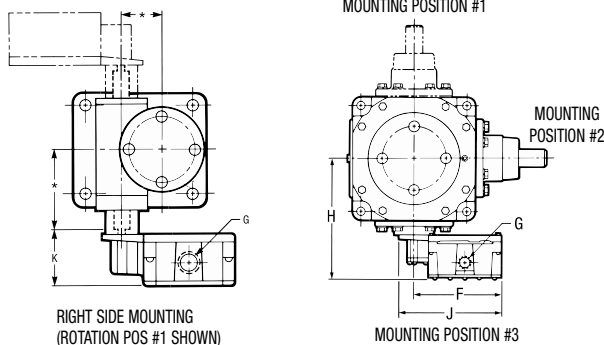

### Note:

- 2, 2.5, 3, 5, 10, 15 and 20-ton jacks or electric cylinders are available with limit switch positions #1, #3, and #5.
- 25, 30, 35, 50 and 75-ton jacks are available in with limit switch positions #1, #4, #7 and #8.
- Limit switches on Bevel Gear® jacks may be mounted in any position.

# OPTIONS GEARED POTENTIOMETERS

Joyce geared potentiometers are ideal for precise, accurate positioning applications. Using a 10-turn potentiometer, a signal is provided as either a change in resistance or current (when supplied with a 4-20 mA instrument transformer), which is proportional to the actual position of the screw. Geared potentiometers are commonly needed when PLCs or computers control jacks.

Geared potentiometers are available on wormgear design jacks of 2-ton to 150-ton capacity. They include a slip clutch to prevent damage due to over-rotation but should always be inspected during installation to ensure that a full range of motion is available throughout the jack travel.

As an additional option, geared potentiometers are available with upper and lower mechanical limit switches. These are common SPDT cam operated switches used for end of travel limits or set points. The standard operating voltage is less than or equal to 48 V (an operating voltage of greater than 48 V is available upon request).

Ordering information is found within specific product sections.

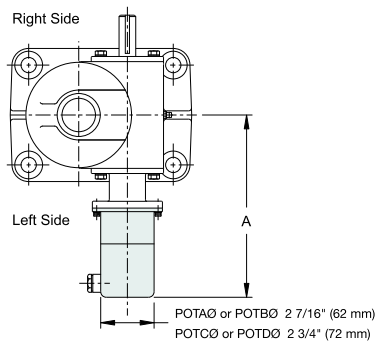

Jack Capacity	POTA and POTB "A"	POTC and POTD "A"
2 Ton	6 3/8	8 1/4
2.5 Ton	6 1/4	8
3 Ton	6 1/4	8
5 Ton	7	8 7/8
10 Ton	7 7/8	9 7/8
15 Ton	7 7/8	9 7/8
20 Ton	8 1/4	10 1/4
25 Ton	9	10 7/8
30 Ton	9	10 7/8
35 Ton	9	10 7/8
50 Ton	10 7/8	12 3/4
75 Ton	12 1/4	14 1/8
100 Ton	12 1/4	14 1/8
150 Ton	12 1/4	14 1/8

Order Codes	Descriptions	Rating
POTA	0-10 V	IP65
POTB	4-20 mA	IP65
POTC	0-10 V with 2 limit switches	IP65
POTD	4-20 mA with 2 limit switches	IP65

Instrument Transformer Characteristics (POTB and POTD)	
Supply Voltage (+U <sub>0</sub> )	24 VDC +/- 20%
Max. Load Impedance (R <sub>0</sub> )	< 500 Ω
Output Current (I <sub>MESS</sub> )	4-20 mA 24 V DC ±20 %, with load ≤500*
*Standard output signal increases as screw extends	

Geared Potentiometer Electrical Characteristics	
Resistance	10 kΩ
Resistance Tolerance	+/- 5 %
Linearity Tolerance	+/- 0.25%
Load Capacity	2 W at 70°C
Standard Residual End Point Resistance	Greater of 0.2% or 1Ω
Operating Temperature	-20°C to 80°C



## POTA – 0-10 VDC / POTB – 4-20mA

- 10-turn geared potentiometer with integrated slip clutch
- Model ratio is selected to maximize resolution and match shaft direction of rotation for each application at time of order
- Housing: Reinforced plastic with aluminum
- Shaft: Stainless steel
- Connector: Cable gland is standard
- Temperature rating: -4°F to 176°F (-20°C to 80°C)
- IP65 rating



## POTC – 0-10 VDC / POTD – 4-20mA With limit switches

- 10-turn geared potentiometer with integrated slip clutch
- Includes 2 adjustable cam-operated limit switches
- Model ratio is selected to maximize resolution and match shaft direction of rotation for each application at time of order
- Housing: Aluminum
- Shaft: Browned steel
- Connector: Cable gland is standard
- Temperature rating: -4°F to 176°F (-20°C to 80°C)
- IP65 rating

## Precise Position Sensing

Joyce can equip machine screw jacks and electric cylinders with an encoder to allow accurate position sensing within increments of 0.001 inches. The encoder combines with your control system to monitor screw travel, number of revolutions, and travel limits.

Choose from a variety of shaft-mounted encoder options, each with proven reliability and requiring virtually no maintenance. For best results, specify encoders for jacks and electric cylinders and have them factory mounted to meet your requirements.

Consider and compare encoder options on page 177 then select the best one for your application. Mating connector cables can be purchased separately. For custom options contact Joyce.

Complete ordering information is available within product sections.

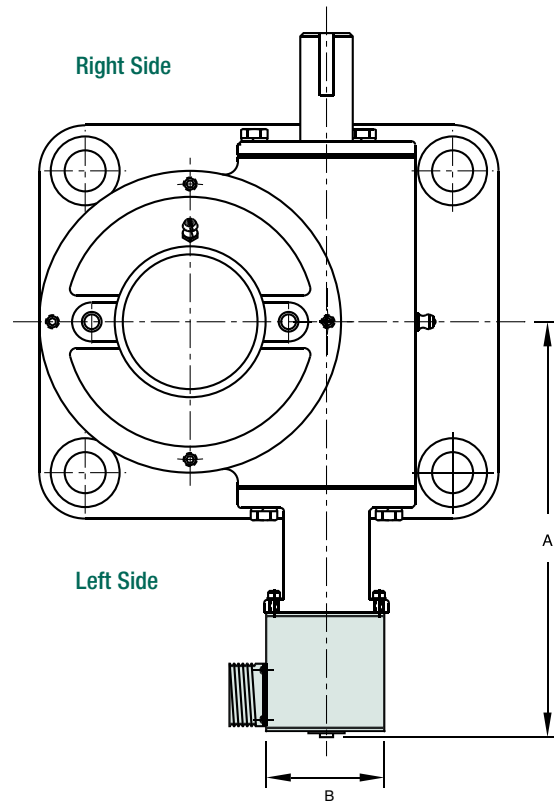

Jack or Electric Cylinder Capacity	ENCA & ENCB		ENCC & ENCD		ENCS		ENCX & ENCY	
	A	B	A	B	A	B	A	B
2 Ton	5.38	2.31 Dia.	6.34	2.5 Dia.	5.84	2.0 Dia.	5.84	2.25 Sq.
2.5 Ton	6.38	2.31 Dia.	7.38	2.5 Dia.	6.88	2.0 Dia.	6.88	2.25 Sq.
3 Ton	6.38	2.31 Dia.	7.38	2.5 Dia.	6.88	2.0 Dia.	6.88	2.25 Sq.
5 Ton	6.38	2.31 Dia.	7.38	2.5 Dia.	6.88	2.0 Dia.	6.88	2.25 Sq.
10 Ton	7.50	2.31 Dia.	8.44	2.5 Dia.	7.94	2.0 Dia.	7.94	2.25 Sq.
15 Ton	7.50	2.31 Dia.	8.44	2.5 Dia.	7.94	2.0 Dia.	7.94	2.25 Sq.
20 Ton	7.88	2.31 Dia.	8.81	2.5 Dia.	8.31	2.0 Dia.	8.31	2.25 Sq.
25 Ton	8.38	2.31 Dia.	9.38	2.5 Dia.	8.88	2.0 Dia.	8.88	2.25 Sq.
30 Ton	8.38	2.31 Dia.	9.38	2.5 Dia.	8.88	2.0 Dia.	8.88	2.25 Sq.
35 Ton	8.38	2.31 Dia.	9.38	2.5 Dia.	8.88	2.0 Dia.	8.88	2.25 Sq.
50 Ton	10.50	2.31 Dia.	11.44	2.5 Dia.	10.94	2.0 Dia.	10.94	2.25 Sq.
75 Ton	11.75	2.31 Dia.	12.63	2.5 Dia.	12.13	2.0 Dia.	12.13	2.25 Sq.
100 Ton	11.75	2.31 Dia.	12.69	2.5 Dia.	12.19	2.0 Dia.	12.19	2.25 Sq.
150 Ton	11.75	2.31 Dia.	12.69	2.5 Dia.	12.19	2.0 Dia.	12.19	2.25 Sq.

Note: Drawings are artist's conception — not for certification; dimensions are subject to change without notice.



## Absolute Encoder with Programmable Operating Ranges ENCA / ENCB



- ENCA 0-10 VDC output, M12 connection (A-coded)
- ENCB 4-20mA output, M12 connection (A-coded)
- Multi-turn absolute analog encoder with 12-bit resolution over the measuring range
- Programmable operating ranges
- A single model has universal application up to 65,536 turns of the jack or actuator
- Stainless steel (nickelized) housing: Stainless steel shaft
- IP64
- Temperature rating: -40° F to 185° F (-40°C to 85°C)

## Absolute Encoder ENCC / ENCD



- ENCC ( Binary) CAN open output, 5-pin M12 connection
- ENCD (Gray) SSI output, 8-pin M12 connection
- Model selected based on required number of turns up to 262,144
- Multi-turn absolute encoder with 18-bit resolution
- Black non-corrosive finish on housing: 303 Stainless steel shaft
- IP67
- Temperature rating: -40° F to 176° F (-40°C to 80°C)

## Stainless Steel Incremental Encoder ENCS



- ENCS 1024 PPR, Quadrature output, 5-pin M12 connection
- Multi-turn encoder
- This encoder model permits an unlimited number of turns
- Compatible with most programmable controllers
- 316 Stainless steel housing: 316 Stainless steel shaft
- IP67
- Temperature rating: -40° F to 158°F (-40°C to 70°C)

## Standard Incremental Encoder ENCX / ENCY



- ENCX 200 PPR, Quadrature output, 6- Pin M5 connection
- ENCY 1024 PPR, Quadrature output, 6-pin M5 connection
- Multi-turn Encoder
- This encoder model permits an unlimited number of turns
- Black non-corrosive finish on housing: 303 Stainless steel shaft
- 6-pin MS connection
- Temperature rating: 32° F to 158 °F (0°C to 70°C)

### ENCA/ENCB (Absolute)

Function 5-pin M12	Pin Connections
I out/U out	1
+ UB	2
Ground	3
Limit 1	4
Limit 2	5

### ENCC (Absolute)

Function 5-pin M12	Pin Connections
	CAN open – Binary
CAN GND/shield	1
+ VDC	2
Ground	3
CAN high	4
CAN low	5

### ENCD (Absolute)

Function 8-pin M12	Pin Connections
	SSI -Gray
Ground	1
+VDC	2
SSI CLK+	3
SSI CLK-	4
SSI Data +	5
SSI Data -	6
Preset	7
DIR	8

### ENCS (Incremental)

Function 5-pin M12	Pin Connections
+ VDC	1
B	2
Common	3
A	4
Z index	5

### ENCX & ENCY (Incremental)

Function 6-pin MS	Pin Connections
Common	A
+VDC	B
A	C
A'	D
B	E
B'	F

Note: Drawings are artist's conception — not for certification; dimensions are subject to change without notice.

# OPTIONS SERVO MOTOR MOUNTS

Joyce offers servo motor mounts for 2, 2-1/2, 3, 5, and 10-ton worm gear screw jacks and electric cylinders. Easily attach the motor of your choice to either side of your jack. These mounts are compatible with various servo motors but Joyce can provide servo motor mounts to meet your exact specifications.

Contact Joyce today and allow us to provide motor mounts that meet your servo motor specifications.

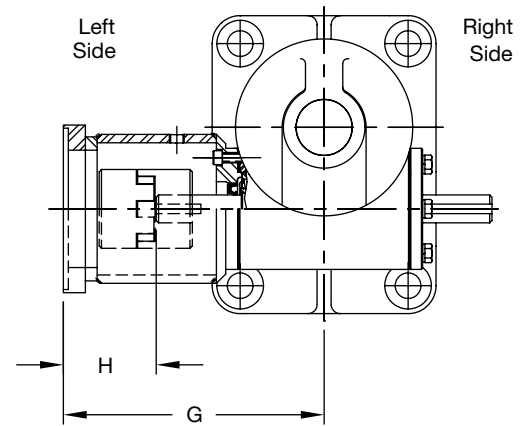
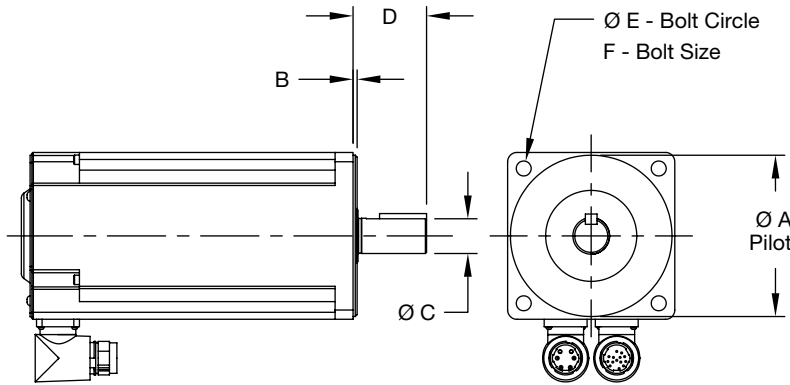

Motor Frame Dimensions (mm)						
Shaft Code	A	B	C	D	E	F
SM01	80.0	2.74	16.0	40.0	100.0	M6x1.00
SM02	95.0	2.74	19.0	40.0	115.0	M8x1.25
SM03	110.0	2.74	24.0	50.0	130.0	M8x1.25
SM04	110.0	2.74	24.0	50.0	130.0	M8x1.25
SM05	130.0	3.12	28.0	60.0	165.0	M10x1.50
SM06	130.0	3.12	28.0	60.0	165.0	M10x1.50

Jack Dimensions (mm)				
Jack Model	Shaft Code	G	H	Max. Coupling Torque N-m
2 Ton Reverse Base, 2-1/2, & 3 Ton	SM01	137.0	52.8	15.2
	SM02	142.0	53.0	24.4
	SM03	152.0	63.0	32.8
	SM04	157.0	68.0	60.0
	SM05	161.8	72.9	32.8
	SM06	167.8	78.9	60.0
5 Ton	SM01	162.7	52.6	15.2
	SM02	167.6	53.3	24.4
	SM03	177.8	63.4	32.8
	SM04	182.8	68.5	60.0
	SM05	187.5	73.2	32.8
	SM06	193.4	79.1	160.0
10 Ton	SM02	193.4	53.7	24.4
	SM04	207.8	68.1	60.0
	SM05	213.2	73.5	32.8
	SM06	219.2	79.5	160.0

Note: Drawings are artist's conception — not for certification; dimensions are subject to change without notice.

# OPTIONS MOTOR MOUNTS AND STOCK MOTORS

Joyce motor mounts allow direct coupling to the motor shaft on either the right (shown) or left side jack input shaft. For easy installation 2-ton through 20-ton wormgear style jacks are available with motor mount adapters for standard NEMA C-Face motors. Jacks supplied with motor mounts are available with and without NEMA C-Faced motors. When motors are included they come with the necessary hardware and coupling keys. Contact Joyce for information about other types of motor mounts (i.e., IEC, pneumatic, etc.).

Motor Mount Dimensions			
Capacity	NEMA Frame Size	A	B
2 ton	56C	6.25	.50
	140TC		
2.5 ton	56C	6.25	.50
	140TC		
3 ton	56C	6.25	.50
	140TC		
5 ton	56C	7.25	.50
	140TC	7.25	.50
	180TC	8.00	.63
10 ton	56C	8.25	.50
	140TC	8.25	.50
	180TC	9.00	.63
15 ton	56C	8.25	.50
	140TC	8.25	.50
	180TC	9.00	.63
20 ton	56C	8.25	.50
	140TC	8.25	.50
	180TC	9.00	.63
	210TC	9.75	.88

Motor Dimensions					
HP	NEMA Frame Size	C	D	E	F
1/3	56C	7.06	9.31	5.94	4.25
1/2	56C	7.06	9.31	5.94	4.25
3/4	56C	7.06	9.31	5.94	4.25
1	143TC	7.19	10.25	6.34	4.56
1 1/2	145TC	7.19	10.25	6.34	4.56
2	145TC	7.19	11.25	6.34	4.56
3	182TC	9.06	17.38	7.50	4.56
5	184TC	9.06	18.75	7.50	4.56
7 1/2	213TC	10.85	15.81	7.50	8.25

Ordering information is found within specific product sections.

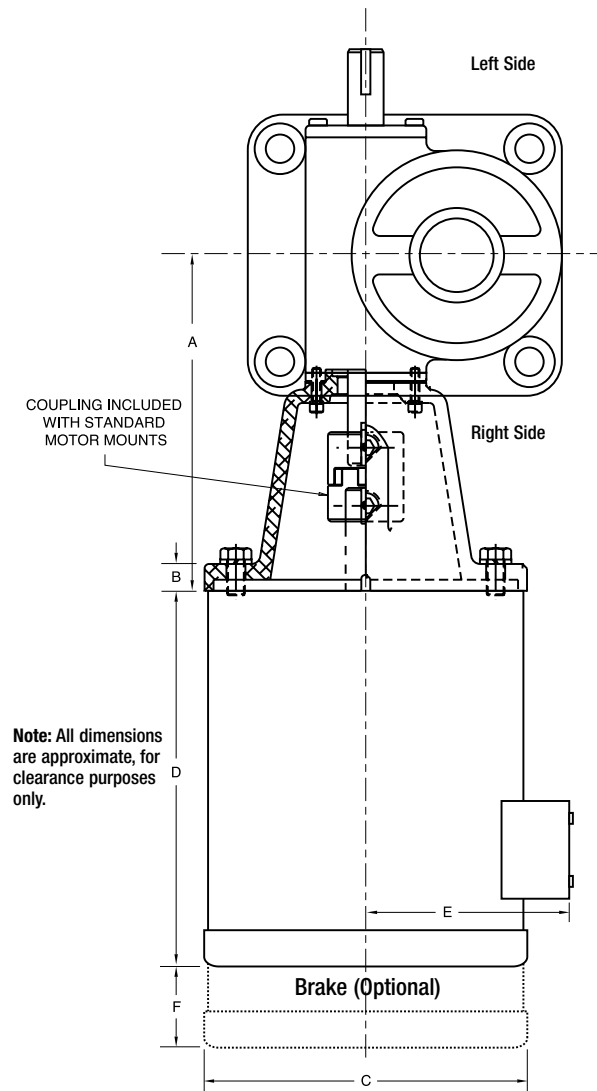

- All standard motors are 3-phase, 60 Hz., 208-230/460 VAC or 230/460 VAC. Other motor options are available. Contact Joyce for motor speeds that exceed 1750 RPM.
- It is important to consider the input torque a direct drive motor must deliver at start up.
- Brake motors (M2) are recommended for double lead jacks, ball screw jacks and actuators, and electric cylinders that are more than 30% efficient.
- If the motor frequency will be varied to provide a “soft” start, an inverter duty motor may be needed.

NOTE: JAX® Online software may be used to size direct-drive motors, but users are advised to evaluate motor start-up torque requirements and adjust motor horsepower accordingly. Contact Joyce for assistance.

Note: Drawings are artist's conception — not for certification; dimensions are subject to change without notice.

# OPTIONS HAND WHEELS AND COUNTERS

Hand Wheel Dimensions						
Jack Capacity	Dimension	4" Diameter HW04	6" Diameter HW06	8" Diameter HW08	10" Diameter HW10	12" Diameter HW12
250, 500 Lb. and 1,000 Lb.	A	4 5/8	6 1/8			
	B	1	2			
	C	3/8	3/4			
1 Ton	A	5 3/8	6 7/8	7 5/8	8 1/2	8 7/8
	B	1/2	1 1/2	2 1/2	3 1/2	4 1/2
	C	5/8	1	1 3/8	1 7/8	2 1/4
2 Ton Standard Base	A	5 7/8	7 1/4	8	9	9 1/4
	B	1/4	1 1/4	2 1/4	3 1/4	4 1/4
	C	0	3/8	3/4	1 1/4	1 5/8
2 Ton Reverse Base	A	5 3/4	7 1/4	8	9	9 1/4
	B	1/4	1 1/4	2 1/4	3 1/4	4 1/4
	C	1 3/4	2 1/8	2 1/2	3	3 3/8
2.5 Ton	A	5 3/4	7 1/4	8	9	9 1/4
	B	1/4	1 1/4	2 1/4	3 1/4	4 1/4
	C	1 1/2	1 7/8	2 1/4	2 3/4	3 1/8
3 Ton	A	5 3/4	7 1/4	8	9	9 1/4
	B	1/4	1 1/4	2 1/4	3 1/4	4 1/4
	C	1 1/2	1 7/8	2 1/4	2 3/4	3 1/8
5 Ton	A	6 3/8	7 3/4	8 3/4	9 1/2	10
	B	0	3/4	1 3/4	2 3/4	3 3/4
	C	1 1/8	1 1/2	1 7/8	2 3/8	2 3/4
10 Ton	A			9 3/8	10 1/4	10 5/8
	B			1 3/4	2 3/4	3 3/4
	C			1 7/8	2 3/8	2 3/4
15 Ton	A			9 3/8	10 1/4	10 5/8
	B			1 1/4	2 1/4	3 1/4
	C			1 3/4	2 1/4	2 5/8
20 Ton	A			9 3/8	10 1/4	10 5/8
	B			3/4	1 3/4	2 3/4
	C			1 1/2	2	2 3/8

These aluminum hand wheels are only recommended for self-locking jacks.

Counter Dimensions							
Dimension	Jack Capacity						
	2 Ton	2.5 Ton	3 Ton	5 Ton	10 Ton	15 Ton	20 Ton
D	4 1/2	4 1/2	4 1/2	5	5 7/8	5 7/8	6

Standard count increases as lifting screw extends, longer worm shafts are available. Ordering information is found within specific product sections.

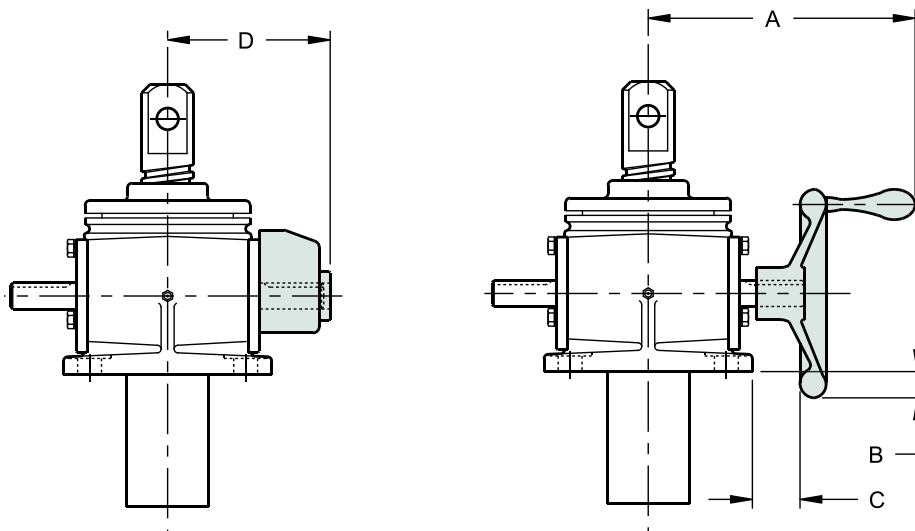

Note: Drawings are artist's conception — not for certification; dimensions are subject to change without notice.



# OPTIONS ANTI-BACKLASH DESIGNS

## Anti-Backlash Designs

Anti-backlash devices are internal jack components used to minimize backlash (free movement between the lifting screw and nut) in machine screw jacks. These devices are used in reversing load applications where the lifting screw position is critical.

These devices are frequently used in steel mill applications where the screw jacks are used to set and maintain the position of the movable upper roll of a rolling mill. In operation, the initial weight of the roll pulls the lifting screw to one side of the internal nut. When steel passes through the rolls, the load reverses on the lifting screw and movement in the opposite direction is limited by the anti-backlash device.

Other common applications include screw jacks used to position communication antennas and solar panels. In these applications, directional changes in the wind can buffet the panels thus affecting the position of the lifting screw. During high wind conditions, anti-backlash devices minimize the lifting screw movement.

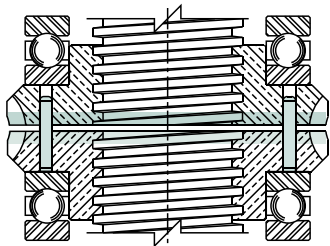

### A-Split Gear Design

- Best suited for light dynamic loads (1/3 jack capacity or less) and full jack capacity for static loads.
- A split gear and dowel pins maintain gear alignment.
- Adjustments are made by tightening the sleeve (housing) cap.
- Typically reduces endplay to 0.010" — 0.015" without increased torque.\*
- Available on translating models, 500-pound to 75-ton (upright and inverted) jacks.
- Available on some keyed models. Contact Joyce.
- Order using an "A" designation in the suffix of the part number.

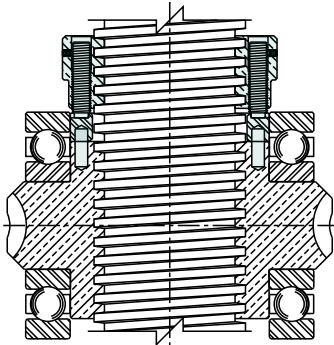

### A90 Design

- Best suited for medium dynamic loads (1/2 to 3/4 jack capacity) and full jack capacity for static loads.
- This design incorporates a hardened steel plate pinned to the top of the internal gear and a secondary nut placed above the steel plate.
- Setting the backlash is accomplished by tightening the dog point set screws located inside the secondary nut. The set screws are externally adjustable.
- Typically reduces endplay to 0.008" — 0.012" without increased torque.\*
- Available on upright translating models, 25-ton to 100-ton capacity jacks.
- Available on some keyed models. Contact Joyce.
- Order using an "A90" designation in the suffix of the part number.

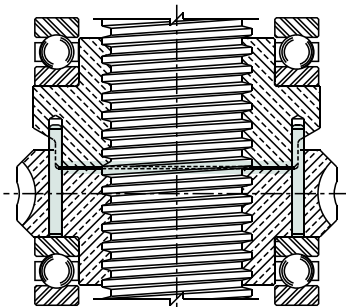

### A95 Design

- Capable of handling full jack capacity in dynamic as well as static conditions.
- This design allows the gear teeth to remain intact and therefore retain their full load carrying capacity.
- Adjust endplay by tightening the sleeve (housing) cap.
- Typically reduces endplay to 0.008" — 0.012" without increased torque.\*
- Available on upright and inverted translating models, 2-ton to 150-ton capacity jacks.
- Order using an "A95" designation in the suffix of the part number.

\*If the backlash is set below the recommended values, torque values will increase significantly and thread wear will accelerate.  
**Ordering information is found within specific product sections.**

Note: Drawings are artist's conception — not for certification; dimensions are subject to change without notice.

## Finishes for Jack Housings

- Gray enamel is the standard finish for Joyce jacks (2-ton and larger) and electric cylinders.
- Miniature jacks with aluminum housings (WJ250, WJ500, WJ1000, WJ51, WJ201, WBL51, WB51, WBL201, & WB201), and integrated actuators are unpainted.
- Standard epoxy (F2) is comprised of a two-component polyamide primer, and a two-component low VOC, polyurethane topcoat (available in green and white).
- STEEL IT® epoxy finish provides a hard, non-toxic finish. It is comprised of a two-part, lead-free epoxy primer with a two-part polyamide epoxy topcoat (which incorporates 316 stainless steel leafing pigment). Approved by USDA for use where incidental food contact may occur.
- Joyce outdoor paint process (F3), is an exclusive paint process that protects against corrosion due to harsh outdoor environments. It incorporates rigorous surface preparation with a premium epoxy primer and topcoat and stainless steel hardware resulting in a durable, corrosion-resistant finish that is in high demand on antenna jacks, solar jacks, mining industry jacks and jacks used in coastal installations.
- Clear coat anodizing is a uniform coating process that increases the corrosion resistance and wear properties of aluminum housings. It will not flake or peel.
- Electroless nickel plating is a thin, uniform coating. When applied to jack housing, it provides superior corrosion resistance and improved wear resistance, while having little effect on the fit of mating components.

## Material and Finishes for Lifting Screws

- Stainless steel lifting screws are standard on WJ250, WJ500, WJ1000, and for all stainless steel jacks. They are available for machine screw jacks, bevel gear jacks, metric jacks, and traveling nut (TN) style integrated actuators.
- Armoloy®, a thin, dense chrome finish, intended to increase wear and corrosion resistance, and improve lubricity. It can also be applied to stainless steel components for superior corrosion resistance. This thin coating (0.0001" — 0.0003") has little effect on the fit of mating components.
- Xylan® coating, which uses a combination of fluoropolymer lubricants and resin binders, significantly reduces the coefficient of friction of components and offers excellent corrosion protection and good chemical resistance. The application of this coating (0.0002" — 0.0007") has little effect on the fit of mating parts.

## Finishes for Input Shafts, Clevis Ends, and Other Components

- Stainless steel worm shafts, standard on WJ250, WJ500, WJ1000, and for all stainless steel jacks, are available as an option on most wormgear style jacks.
- Armoloy®, a thin, dense chrome finish, intended to increase wear and corrosion resistance, and improve lubricity. It can also be applied to stainless steel components for superior corrosion resistance. This thin coating (0.0001" — 0.0003") has little effect on the fit of mating components.
- Electroless nickel plating is a thin, uniform coating. When applied to worm and pinion input shafts, it provides superior corrosion resistance and improved wear resistance, while having little effect on the fit of mating components.
- Zinc coating provides protection against corrosion, increases surface lubricity, and improves the aesthetic appearance of components. The effect it has on the fit of mating components is dependent on the thickness of its application (0.0002" — 0.0010").



Standard Enamel Finish



STEEL IT® Epoxy



Standard Epoxy



Electroless Nickel Finish

To order special finishes and materials, contact Joyce.

# OPTIONS TRUNNION MOUNTS

## Options – Trunnion Mounting Adapters

Trunnion adapter plates bolt to the base of 2-ton through 20-ton jacks. They include precision bores for trunnion pins. These are frequently used in installations where a single\* jack moves through an arc during operation. This jack is often configured with a motor mount or as a ComDRIVE®.

### Design Information

The customer supplied trunnion pins should be ground to the “D” diameter shown in the table below. These pins should be made of steel with hardness greater than 30 HRC, a yield strength greater than 60,000 psi and be supported to within 1/16 inch of the trunnion adapter plate. Therefore, the distance between the customer’s mounting surfaces should be no more than “A” + 0.13 inch.

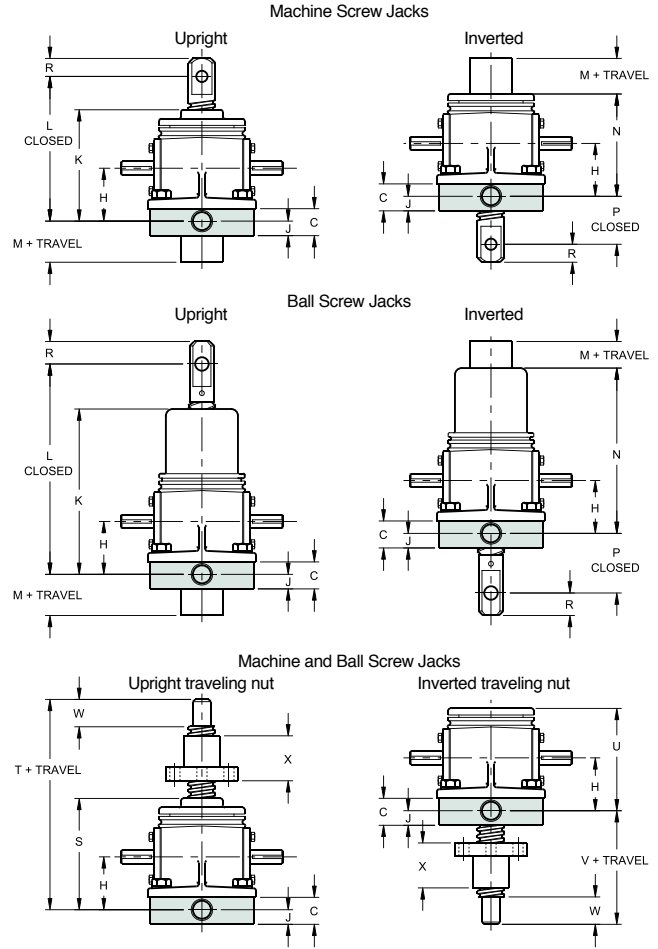
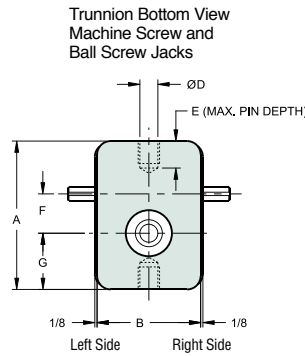

Jack Model	Common Dimensions										Upright - Inverted						Upright - Inverted Traveling Nut					
	A	B	C	D	E	F	G	H	J	K	L	M	N	P	R	S	T	U	V	W	X	
Machine Screw	2 Ton RWJT/DRWJ	7 1/4	3 1/4	1 1/4	.7491 .7479	1 1/4	1.703	3 1/8	2 5/16	11/16	4 11/16	5 3/8	0	4 5/16	2 1/16	11/16	4 11/16	8 3/16	4 3/4	4 13/16	1 1/16	1 1/2
	3 Ton WJ/DWJ	6 1/2	3 7/8	1 1/4	.7491 .7479	1 1/4	1.750	2 1/2	2 5/16	11/16	4 3/8	6 5/8	1/8	4 3/8	2 3/8	3/4	4 3/8	8 1/8	4 3/8	5 1/8	3/4	2
	5 Ton WJT/DWJ	8 1/4	5 3/4	1 1/2	.9991 .9979	1 1/2	2.188	3 1/8	2 15/16	13/16	6 3/16	7 3/16	0	5 11/16	1 13/16	1	6 3/16	11 3/16	6 3/16	6 13/16	1 1/2	2 1/2
	10 Ton WJ/DWJ	9	7 1/4	2	1.2488 1.2472	1 1/2	2.598	3	3 1/8	1 1/8	6 1/8	7 1/2	0	6	2 1/2	1 5/16	6 1/8	13 1/8	6 1/8	8 7/8	1 31/32	3
	15 Ton WJ/DWJ	9 1/2	7 1/2	2 1/4	1.4988 1.4972	1 3/4	2.598	3 1/2	3 3/4	1 1/4	7	8 3/8	0	6 7/8	2 5/8	1 5/16	7	13	7	7 11/16	1 31/32	3
	20 Ton WJ/DWJ	11 1/4	8	2 1/4	1.4988 1.4972	1 3/4	2.598	4 1/4	4 1/4	1 1/4	8 1/4	9 5/8	0	8 1/4	2 5/8	1 3/8	8 1/4	14 1/4	8 1/4	8	1 15/16	3
Ball Screw	2 Ton RWB/RHWB	7 1/4	3 1/4	1 1/4	.7491 .7479	1 1/4	1.703	3 1/8	2 5/16	11/16	7	9 7/16	9/16	7	2 9/16	3/4	4 11/16	9 7/16	4 11/16	6 1/16	1 1/8	3 1/8
	5 Ton WB	8 1/4	5 3/4	1 1/2	.9991 .9979	1 1/2	2.188	3 1/8	2 15/16	13/16	9 7/16	12 3/4	11/16	9 7/16	4 3/4	1 1/4	6 3/16	12 3/16	6 3/16	7 1/2	1 1/8	4 1/2
	5 Ton HWB	8 1/4	5 3/4	1 1/2	.9991 .9979	1 1/2	2.188	3 1/8	2 15/16	13/16	9 7/16	12 3/4	11/16	9 7/16	4 3/4	1 1/4	6 3/16	11 5/8	6 3/16	6 15/16	1 1/8	3 25/32
	10 Ton WBL	9	7 1/4	2	1.2488 1.2472	1 1/2	2.598	3	3 1/8	1 1/8	9 9/16	12 3/4	11/16	9 9/16	3	1 1/4	6 1/8	12 3/4	6 1/8	8 7/16	1 3/4	4 1/2
	10 Ton HWBL	9	7 1/4	2	1.2488 1.2472	1 1/2	2.598	3	3 1/8	1 1/8	9 9/16	12 3/4	11/16	9 9/16	3	1 1/4	6 1/8	12 3/16	6 1/8	7 7/8	1 3/4	3 25/32
	10 Ton WB/HWB	9	7 1/4	2	1.2488 1.2472	1 1/2	2.598	3	3 1/8	1 1/8	13 1/8	16 3/8	11/16	13 1/8	3 1/8	1 1/4	6 1/8	15 5/16	6 1/8	10 3/8	2	6 5/8
	20 Ton WB	11 1/4	8	2 1/4	1.4988 1.4972	1 3/4	2.598	4 1/4	4 1/4	1 1/4	15 3/16	19 7/8	3/8	15 3/16	4	1 1/2	8 1/4	18 1/4	8 1/4	12	2 3/4	6 3/4

Trunnion adapters mounted to inverted jacks will decrease the minimum closed dimension and may shorten the travel.

\*Contact Joyce if multiple trunnion-mounted jacks will be used in a system.

Note: Drawings are artist’s conception — not for certification; dimensions are subject to change without notice.

# ACCESSORIES PILLOW BLOCKS AND FLANGE BLOCKS

Joyce ductile iron pillow blocks and flange blocks include self-aligning replaceable bearings that are pre-lubricated with lithium grease. They include steel retainers and nitrile rubber seals with steel guards.

Pillow blocks and flange blocks are suitable for shaft supports and bearing supports for rotary screws on KFTN jacks under normal duty operation.

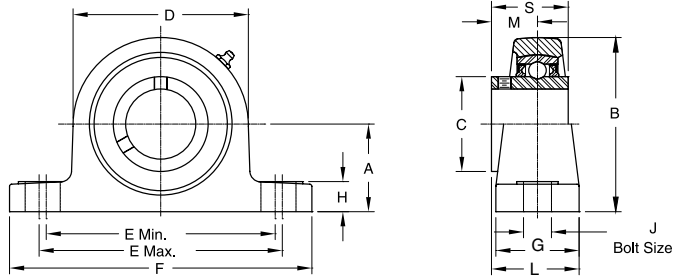

## 2 Bolt Pillow Blocks – Ductile Iron Housing – For Low Shaft Height – Setscrew Lock – Wide Inner Ring

Part Number	Shaft Size	A	B	C	D	E Min.	E Max.	F	G	H	J	L	M	S	Wt. Lbs.
PB-050	1/2	1 1/16	2 1/8	0.969	2 1/4	3 3/8	3 5/8	4 3/4	1 3/8	33/64	3/8	1 5/16	0.626	1.079	1.2
PB-063	5/8														
PB-075	3/4	1 1/4	2 1/2	1.142	2 5/8	3 3/4	3 31/32	5 1/32	1 1/2	35/64	3/8	1 15/32	0.720	1.220	1.9
PB-100	1	1 5/16	2 5/8	1.339	2 25/32	4	4 1/4	5 1/2	1 9/16	19/32	3/8	1 9/16	0.776	1.339	2.4
PB-125	1 1/4	1 13/16	3 19/32	1.843	3 27/32	4 13/16	5 3/16	6 9/16	1 7/8	45/64	1/2	1 15/16	1.000	1.689	3.8
PB-144	1 7/16														
PB-150	1 1/2	1 15/16	3 27/32	2.063	4 3/16	5 5/16	5 11/16	7 1/8	2 1/16	3/4	1/2	2 7/32	1.189	1.937	4.8
PB-169	1 11/16	2 1/16	4 1/8	2.260	4 17/32	5 9/16	5 15/16	7 7/16	2 1/8	25/32	1/2	2 1/4	1.189	1.937	5.4
PB-175	1 3/4														
PB-200	2	2 7/16	4 27/32	2.705	5 5/16	6 7/8	7 3/8	9 1/8	2 3/8	29/32	5/8	2 1/2	1.315	2.189	8.7

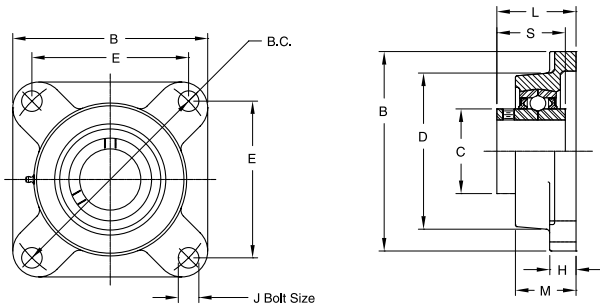

## 4 Bolt Flange Blocks – Ductile Iron Housing – Setscrew Lock – Wide Inner Ring

Part Number	Shaft Size	B	B.C.	C	D	E	H	J	L	M	S	Wt. Lbs.
FB-050	1/2	3	3	.969	2 3/32	2 1/8	7/16	3/8	1 7/32	31/32	1.079	1.0
FB-063	5/8											
FB-075	3/4	3 3/8	3 5/8	1.142	2 3/8	2 1/2	19/32	3/8	1 15/32	1 5/32	1.220	1.5
FB-088	7/8	3 21/32	3 57/64	1.339	2 3/4	2 3/4	19/32	7/16	1 17/32	1 3/16	1.339	1.9
FB-100	1											
FB-125	1 1/4	4 9/16	5 1/8	1.843	3 9/16	3 5/8	11/16	1/2	1 27/32	1 3/8	1.689	4.4
FB-144	1 7/16											
FB-150	1 1/2	5 3/32	5 43/64	2.063	4 1/32	4	11/16	1/2	2 1/8	1 17/32	1.937	5.6
FB-175	1 3/4	5 5/16	5 27/32	2.260	4 1/4	4 1/8	23/32	1/2	2 1/8	1 9/16	1.937	6.0

Note: Drawings are artist's conception — not for certification; dimensions are subject to change without notice.



# ACCESSORIES MITER GEAR BOXES

Joyce miter gear boxes are specifically engineered for use with Joyce jacks and actuators in multiple jack systems. Miter gear boxes used in such systems effectively raise unevenly distributed loads. When driven shaft turns per inch of travel are the same, total synchronization is assured because all models have a uniform lifting speed. Arrows in assembly drawings below indicate shaft rotation.

Standard Joyce miter gear boxes are available in 1:1 and 2:1 ratios. Other ratios are available in the RC series units. Four-shaft units are also available in the RC-18 through RC-204 and the MKA.

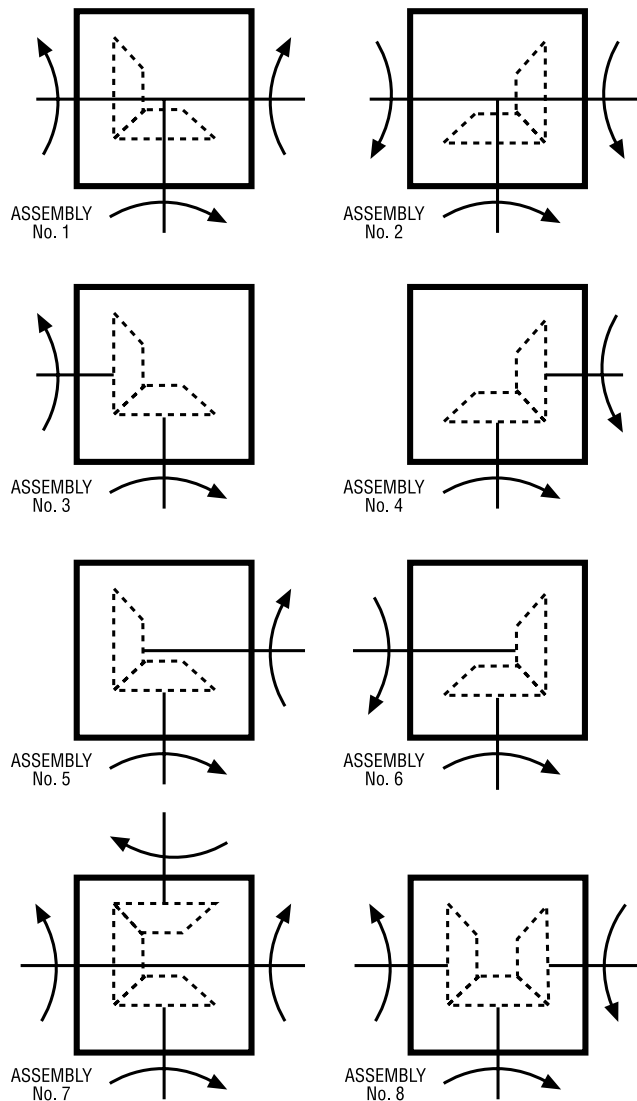

Assembly No. 7 and 8 availability:

- RC-18 RC-38
- RC-99 RC-204
- MKA

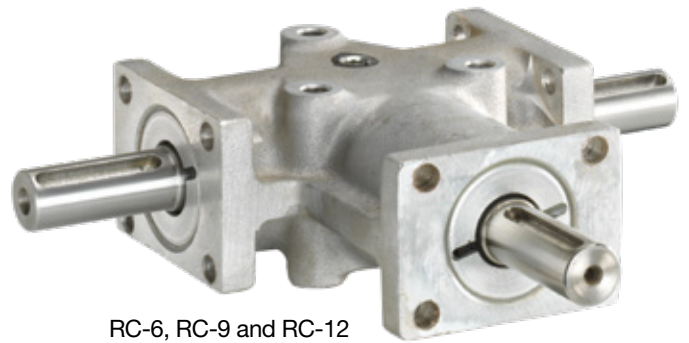

RC-6, RC-9 and RC-12



RC-15 through RC-204



MKA

Note: Drawings are artist's conception — not for certification; dimensions are subject to change without notice. When ordering miter gear boxes specify model numbers and assembly numbers.

# ACCESSORIES MITER GEAR BOXES

## RC-6 THROUGH RC-12

### Lubrication

Units are lifetime lubricated.

RC-6 shafts feature flats (shown below).

RC-9 and RC-12 models have keyways.

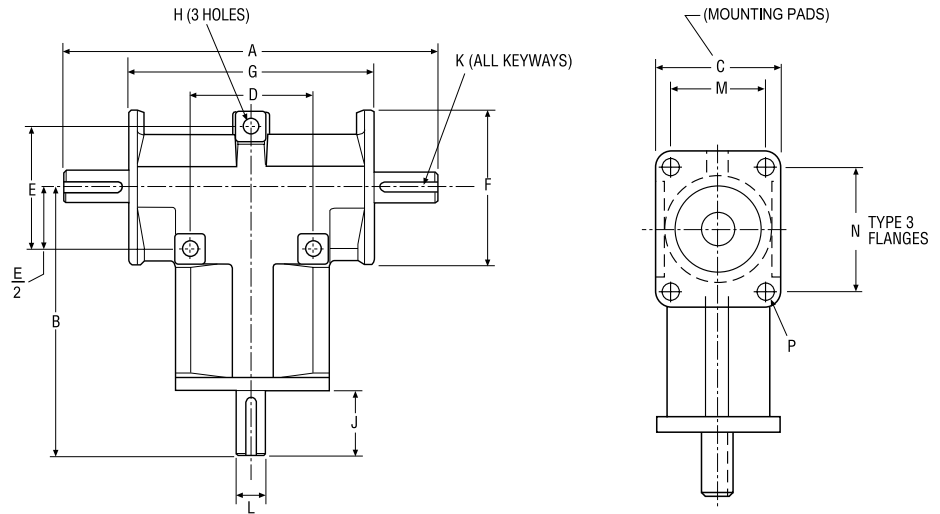
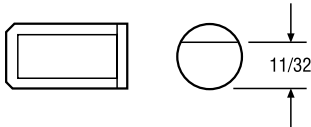

Model No.	Ratio	Max. Torque Rating (In. Lbs.)*	Max. HP @ 400 RPM	Max. RPM	A	B	C	D	E	F	G	H	J	K	L	M	N	P	Approx. Wt. (Lbs.)
RC-6	1:1	36	0.21	5,000	4 5/16	2 15/16	1 1/4	1 5/16	1 5/16	1 5/8	2 3/4	7/32	25/32		3/8	7/8	1 3/16	3/16	3/4
RC-6	2:1	12	0.06	5,000	4 5/16	2 15/16	1 1/4	1 5/16	1 5/16	1 5/8	2 3/4	7/32	25/32		3/8	7/8	1 3/16	3/16	3/4
RC-9	1:1	130	0.75	5,000	7 3/8	4 13/16	2	1 7/8	1 7/8	2 1/2	4 1/4	9/32	1 9/16	3/16 x 1 3/8	5/8	1 3/8	1 7/8	9/32	3
RC-9	2:1	51	0.30	5,000	7 3/8	4 13/16	2	1 7/8	1 7/8	2 1/2	4 1/4	9/32	1 9/16	3/16 x 1 3/8	5/8	1 3/8	1 7/8	9/32	3
RC-12	1:1	382	2.17	5,000	9 1/8	6 9/16	3	3	3	3 7/8	6	3/8	1 9/16	3/16 x 1 3/8	3/4	2 1/4	3	3/8	8
RC-12	2:1	148	0.85	5,000	9 1/8	6 9/16	3	3	3	3 7/8	6	3/8	1 9/16	3/16 x 1 3/8	3/4	2 1/4	3	3/8	8

\* Torque @ 100 RPM and 750 hours of life.

## RC-15

### Lubrication

Fill with 6 ounces. EP-90 gear oil for normal operation. Units are shipped less lubricant.

Dimensions are representative of 1:1 ratio miter boxes.

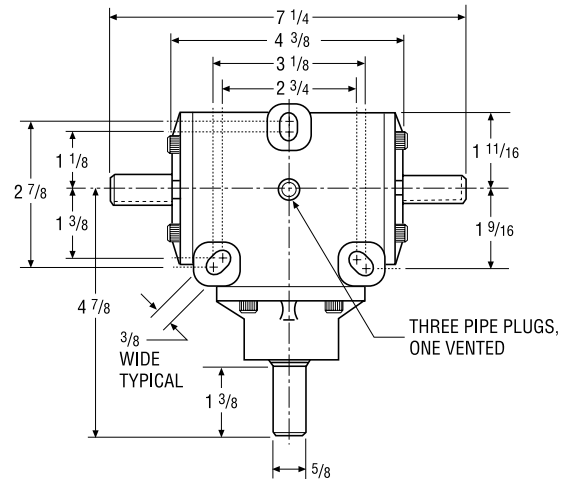
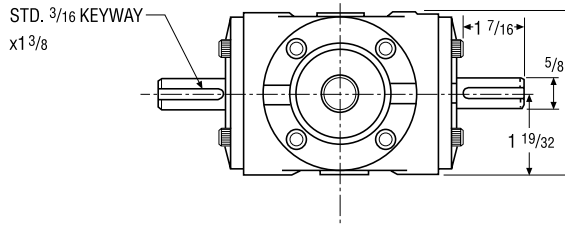

Model No.	Ratio	Max. Torque Rating (In. Lbs.)*	Max. HP @ 400 RPM	Max. RPM	Approx. Weight (Lbs.)
RC-15	1:1	357	2.03	5,000	5
RC-15	2:1	151	0.87	5,000	5

\* Torque @ 100 RPM and 750 hours of life.

Note: Drawings are artist's conception — not for certification; dimensions are subject to change without notice.

# ACCESSORIES MITER GEAR BOXES

## RC-18 THROUGH RC-204

### Lubrication

Units shipped less lubricant.  
Fill with EP-90 gear oil.

Model RC-18	1 pint
Model RC-38	1 1/2 pints
Model RC-99	4 1/2 pints
Model RC-204	8 pints

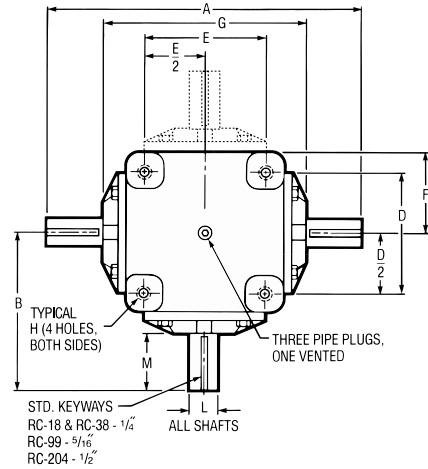
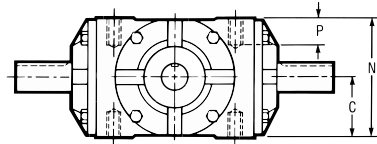

Model No.	Ratio	Max. Torque Rating (In. Lbs.)*	Max. HP @ 400 RPM	Max. RPM	A	B	C	D	E	F	G	H	L	M	N	P	Approx. Wt. (Lbs.)
RC-18	1:1	2154	10.78	3000	11	5 1/2	2 1/16	4 1/4	4 1/4	2 3/4	7	3/8 - 16	.9950 .9980	2	4 1/8	11/16	26
RC-18	2:1	569	3.24	5000	11	7 3/8	2 1/16	4 1/4	4 1/4	2 3/4	7	3/8 - 16	.9950 .9980	2	4 1/8	11/16	26
RC-38	1:1	4776	23.08	2200	13	6 1/2	2 13/16	4 1/2	4 1/2	2 7/8	8	1/2 - 13	1.2495 1.2480	2 1/2	5 5/8	7/8	39
RC-38	2:1	1211	6.85	4400	13	8 3/8	2 13/16	4 1/2	4 1/2	2 7/8	8	1/2 - 13	1.2495 1.2480	2 1/2	5 5/8	7/8	39
RC-99	1:1	13300	69.78	1600	16 1/2	8 1/4	3 3/4	6	6	4 1/8	10 5/8	1/2 - 13	1.3745 1.3730	2 15/16	7 1/2	1 3/8	72
RC-99	2:1	3446	19.24	3100	16 1/2	11 11/16	3 3/4	6	6	4 1/8	10 5/8	1/2 - 13	1.3745 1.3730	2 15/16	7 1/2	1 3/8	72
RC-204	1:1	29035	155.76	1200	19	9 1/2	4 3/4	8	8	4 15/16	13	5/8 - 11	1.9995 1.9980	3	9 1/2	1 1/4	172
RC-204	2:1	8156	45.05	2300	19	9 1/2	4 3/4	8	8	4 15/16	13	5/8 - 11	1.9995 1.9980	3	9 1/2	1 1/4	172

\*Torque @ 100 RPM and 750 hours of life.

## MKA

### Lubrication

Units shipped less lubricant.  
Fill with EP-90 gear oil.

Model MKA	1 1/4 pints
-----------	-------------

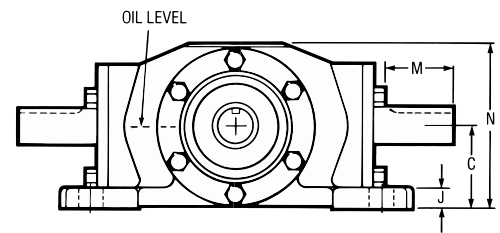
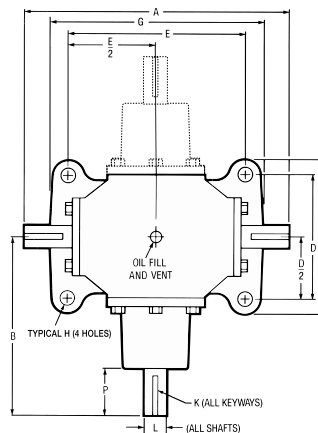

Model No.	Max. Torque Rating (In. Lbs.)	A	B	C	D	E	F	G	H	J	K	L	M	N	P	Approx. Wt. (Lbs.)
MKA	3,000	12	8	2 1/4	5 1/2	8	6 7/8	9 9/16	11/16	1/2	1/4 x 1/8 x 1 1/2	1.0005 .9995	1 31/32	4 9/16	2 1/8	33

Note: Drawings are artist's conception — not for certification; dimensions are subject to change without notice.

# ACCESSORIES FLEXIBLE COUPLINGS

Joyce Model S and Model F geared couplings offer greater torque capacity than jaw couplings. With more gear teeth around the inner circumference of the coupling, plus high torsional, radial and angular stiffness mean that you get a more durable coupling.

Joyce Model S sleeve-type gear couplings are available in flex/rigid and flex/flex configurations.

Model F flange-type gear couplings offer superior radial-misalignment capability and radial flexibility.

Model J jaw-type couplings are ideal for many general industrial applications, require no lubrication and are resistant to oil, grease, moisture and other contaminants.



Model S Coupling

## Specifying Information

When specifying hub sizes, please refer to the table to determine the three digit code. The first digit is the whole number of inches in shaft diameter, while the next two digits give the decimal equivalents of fractional inches.

1      63      = 1 5/8" dia. bore  
 shaft      shaft  
 diameter      diameter  
 in inches      decimal

Fraction	Dec. Code	Fraction	Dec. Code
0	00	1/2	50
1/16	06	9/16	56
1/8	13	5/8	63
3/16	19	11/16	69
1/4	25	3/4	75
5/16	31	13/16	81
3/8	38	7/8	88
7/16	44	15/16	94

**Ordering Information** — Order must indicate coupling size, coupling type (S = sleeve; F = flange; J = jaw), large diameter hub code, hub type (F = flex; R = rigid), small diameter hub code, hub type (F or R), and fit type (S = slip; I = interference).

**Example: for sleeve and flange type**

10	S	163	F	125	F	S
coupling size	coupling type	large diameter hub code	hub type	small diameter hub code	hub type	fit type

**Example: for jaw type**

09	J	100	88
coupling size	coupling type	large diameter hub code	small diameter hub code

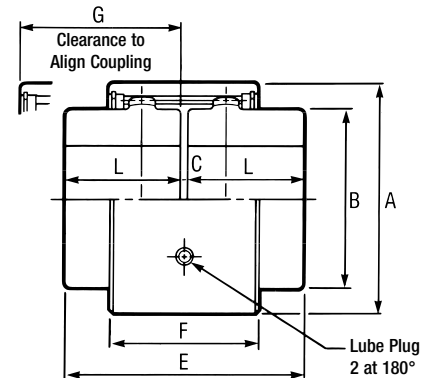

## Model S Sleeve-Type

Size	Max. Bore (In.)	Load Capacity		Max. (RPM x 10 <sup>3</sup> )	Parallel Offset Capacity (In.)	Lube Capacity			Dimension — Inch							Wt. Solid Hubs (Lbs.)	WR <sup>2</sup> Solid Hubs (Lb. In. <sup>2</sup> )
		HP/100 (RPM)	Torque (In. Lbs. x 10 <sup>3</sup> )			Grease		Oil Volume	A	B	L	C	E	F	G		
						Weight	Volume										
6S	1 1/16	4.5	2.84	19.0	.009	3/32 oz.	.006 pt.	.002 pt.	2 3/8	1 9/16	1 3/16	3/32	2 15/32	1 13/32	1 1/2	2.0	.86
8S	1 5/16	7.0	4.41	16.0	.009	5/16 oz.	.019 pt.	.006 pt.	2 13/16	1 31/32	1 13/32	3/32	2 29/32	1 13/32	1 1/2	3.3	2.4
10S	1 5/8	15.5	9.77	12.6	.015	11/32 oz.	.020 pt.	.006 pt.	3 9/16	2 3/8	1 9/16	3/32	3 7/32	1 27/32	1 7/8	6.1	8.1
12S	1 15/16	22	13.9	11.5	.015	3/8 oz.	.022 pt.	.007 pt.	3 15/16	2 25/32	1 25/32	3/32	3 21/32	1 27/32	1 15/16	8.7	13.5
15S	2	31	19.5	11.0	.039	7/8 oz.	1/16 pt.	1/64 pt.	4 1/8	2 15/16	1 15/16	1/8	4	2 25/32	2 29/32	11.5	21.1
20S	2 5/8	51	32.1	8.8	.045	1 5/8 oz.	1/8 pt.	1/32 pt.	5 1/8	3 3/4	2 7/16	1/8	5	3 3/16	3 5/16	21.5	60.8

- Notes: 1. Load capacities listed are the ratings based on full 1° misalignment per gear mesh.  
 2. Maximum bore listed are based on using a square key.  
 3. Speeds shown are without dynamic balancing.  
 4. Slip fit is standard.

Note: Drawings are artist's conception — not for certification; dimensions are subject to change without notice.

# ACCESSORIES FLEXIBLE COUPLINGS



Model F Coupling

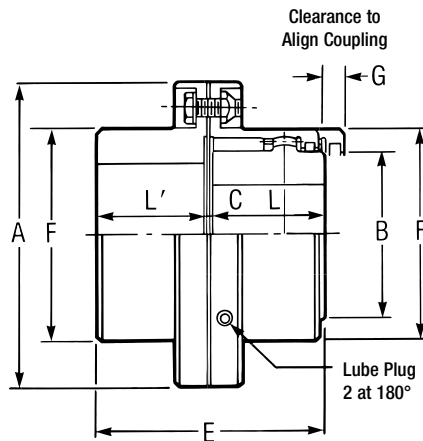

Model F Flange-Type																			
Size	Max. Bore (In.)		Load Capacity		Max. (RPM x 10 <sup>3</sup> )	Lube Capacity			Dimension — Inch							Wt. Solid Hubs (Lbs.)	WR <sup>2</sup> Solid Hubs (Lb. In. <sup>2</sup> )		
	Flex. Half	Rigid Half	HP/100 (RPM)	Torque (In. Lbs. x 10 <sup>3</sup> )		Grease		Oil Volume	A	B	L	L'	C	E	F			G	
						Weight	Volume												
10F	1 5/8	2 1/8	15.5	9.77	6.5	.6 oz.	1/32 pt.	1/64 pt.	4 9/16	2 27/64	1 11/16	1 9/16	3/16	3 7/16	3 7/64	7/16	9.4	18.2	
15F	2	2 3/4	31	19.5	5.3	1 1/8 oz.	1/16 pt.	1/32 pt.	6	2 15/16	1 15/16	1 27/32	5/32	3 15/16	3 29/32	13/32	18.8	66	
20F	2 5/8	3 3/8	51	32.1	5.0	2 1/2 oz.	1/8 pt.	1/16 pt.	7	3 3/4	2 7/16	2 9/32	5/32	4 7/8	4 7/8	1/2	31.4	142	

- Notes: 1. Load capacities listed are the ratings based on full 1° misalignment per gear mesh.  
 2. Shrouded bolt designs are standard, but exposed will be furnished upon request.  
 3. Maximum bore listed are based on using a square key.  
 4. Speeds shown are without dynamic balancing.  
 5. Slip fit is standard.

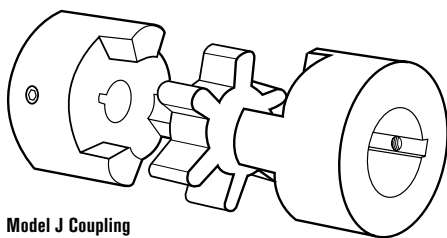

Model J Coupling

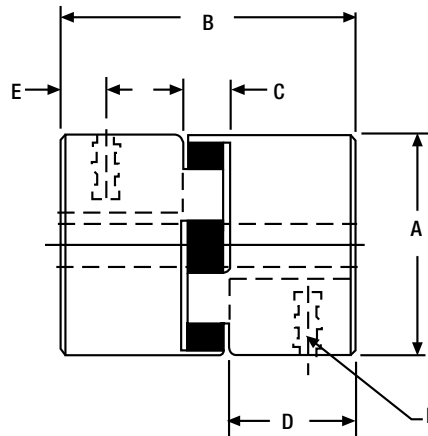

Model J Jaw-Type										
Size	Max. Bore (In.)	Load Capacity Torque (In. Lbs.)	Dimension — Inch						Wt. Solid Hubs (Lbs.)	WR <sup>2</sup> Solid Hubs (Lb. In. <sup>2</sup> )
			A	B	C	D	E	F		
03J	.375	3.5	.62	.81	.27	.27	.13	#6-32	.1	.003
05J	.563	26.3	1.08	1.72	.48	.62	.31	1/4-20	.3	.054
07J	.750	43.2	1.36	2.00	.50	.75	.38	1/4-20	.6	.115
08J	.875	90.0	1.75	2.12	.50	.81	.31	1/4-20	1.0	.388
09J	1.000	144.0	2.11	2.12	.50	.81	.44	1/4-20	1.5	.772

Note: Torque values based on nitrile insert, other insert material available upon request.

Note: Drawings are artist's conception — not for certification; dimensions are subject to change without notice.

# ACCESSORIES SHAFTING

Joyce shafting matches perfectly with Joyce jacks and couplings to meet a wide range of system requirements. Shafting is made from cold-finished 1018 steel, with ends machined to ANSI-standard keyways. For further information on common jack system arrangements, refer to page 195.

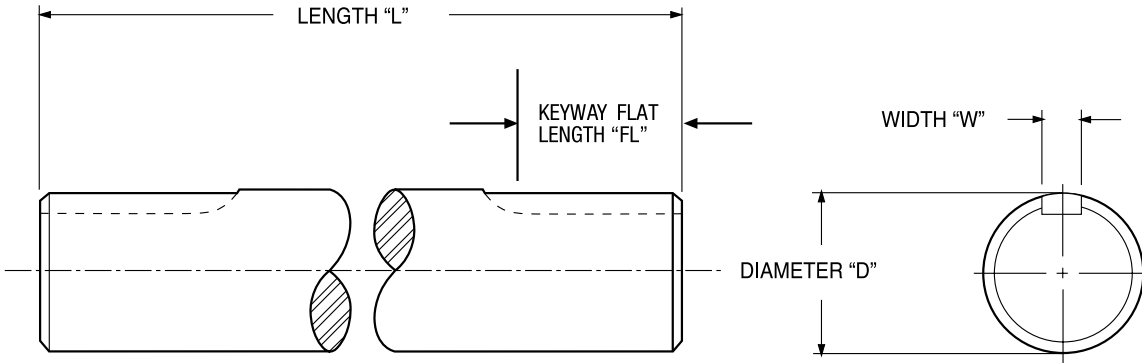

Dimensions and Minimum Shaft Length																			
Model		S50	S63	S75	S88	S100	S113	S125	S138	S150	S163	S175	S188	S200	S213	S225	S238	S250	S262
Minimum Shaft Length* "L"	Flange	7	7	7	7	7	7	7	7	7	7	7	8	8	10	10	10	10	10
	Sleeve	5	5	5	5	5	6	6	6	7	7	7	8	8	10	10	10	10	10
Shaft Diameter "D" Inches	Nominal	1/2	5/8	3/4	7/8	1	1 1/8	1 1/4	1 3/8	1 1/2	1 5/8	1 3/4	1 7/8	2	2 1/8	2 1/4	2 3/8	2 1/2	2 5/8
	Actual	.500 .498	.625 .623	.750 .748	.875 .873	1.000 .998	1.125 1.123	1.250 1.248	1.375 1.373	1.500 1.498	1.625 1.623	1.750 1.748	1.875 1.872	2.000 1.997	2.125 2.122	2.250 2.247	2.375 2.372	2.500 2.497	2.625 2.621
Keyway Width "W"		1/8	3/16	3/16	3/16	1/4	1/4	1/4	5/16	3/8	3/8	3/8	1/2	1/2	1/2	5/8	5/8	5/8	5/8
Keyway Flat Length "FL"		1.25	1.25	1.25	1.25	1.25	1.5	1.5	1.75	1.75	1.75	2	2	2	2.5	2.5	2.5	2.5	2.5

\*These are the minimum shaft lengths that can be ordered when Joyce Model "S" sleeve type couplings or "F" flange-type couplings are selected. See pages 188 and 189 for coupling information.

Note: Drawings are artist's conception — not for certification; dimensions are subject to change without notice.

# ACCESSORIES SHAFTING

## To use this chart, follow these steps:

1. Find a "Shaft Torque" value in the far left column that is greater than, or equal to, your calculated torque value.
2. Move to the second column to find your "Nominal Shaft Diameter" (round up to arrive at an offered shaft size).
3. The third column shows the maximum allowable shaft span before supports (pillow blocks) are required.
4. Compare your actual shaft speed (RPM) with the maximum allowable speed (RPM) for the shaft you have chosen. If you are above the allowable shaft speed, then increase the shaft size until it falls into the allowable range.

Diameter Selection Chart			Maximum Allowable RPMs***										
Shaft Torque (Inch/Lbs.)	Nominal Shaft Diameter* (Inches)	Maximum** Distance Between Supports (Inches)	Shaft Lengths (Inches)										
			36	48	60	72	84	96	108	120	132	144	156
20	0.51	54.6	1802	1014	649	450	331	253	200	162	134	113	96
40	0.73	61.3	2143	1205	771	536	394	301	238	193	159	134	114
50	0.81	65.5	2372	1334	854	593	436	333	264	213	176	148	126
80	0.87	68.8	2548	1433	917	637	468	358	283	229	190	159	136
100	0.92	71.4	2695	1516	970	674	495	379	299	243	200	168	143
150	1.01	76.3	2982	1677	1074	746	548	419	331	268	222	186	159
200	1.09	80.1	3204	1802	1154	801	589	451	356	288	238	200	171
250	1.15	83.1	3388	1906	1220	847	622	476	376	305	252	212	180
300	1.21	85.7	3546	1995	1277	887	651	499	394	319	264	222	189
350	1.25	87.9	3686	2073	1327	921	677	518	410	332	274	230	196
400	1.30	89.9	3811	2144	1372	953	700	536	423	343	283	238	203
450	1.34	91.7	3925	2208	1413	981	721	552	436	353	292	245	209
500	1.37	93.3	4029	2266	1451	1007	740	567	448	363	300	252	215
600	1.44	96.2	4217	2372	1518	1054	775	593	469	380	314	264	225
700	1.49	98.7	4383	2465	1578	1096	805	616	487	394	326	274	233
800	1.54	100.9	4532	2549	1631	1133	832	637	504	408	337	283	241
900	1.59	102.9	4667	2625	1680	1167	857	656	519	420	347	292	249
1000	1.63	104.7	4792	2695	1725	1198	880	674	532	431	356	299	255
1250	1.72	108.7	5067	2250	1824	1267	931	712	563	456	377	317	270
1500	1.80	112.0	5303	2983	1909	1326	974	746	589	477	394	331	282
1750	1.92	114.9	5511	3100	1984	1378	1012	775	612	496	410	344	293
2000	1.94	117.5	5698	3205	2051	1425	1047	801	633	513	424	356	303
2250	2.00	119.8	5869	3301	2113	1467	1078	825	652	528	437	367	313
2500	2.05	122.0	6025	3389	2169	1506	1107	847	669	542	448	377	321
3000	2.15	125.7	6306	3547	2270	1577	1158	887	701	568	469	394	336
3250	2.19	127.4	6434	3619	2316	1608	1182	905	715	579	479	402	343
3500	2.23	129.0	6554	3687	2359	1639	1204	922	728	590	487	410	349
4000	2.31	131.9	6776	3812	2440	1694	1245	953	753	610	504	424	361
4500	2.38	134.5	6979	3926	2512	1745	1282	981	775	628	519	436	372
5000	2.44	136.9	7165	4030	2579	1791	1315	1008	796	645	533	448	382
6000	2.55	141.1	7499	4218	2700	1875	1377	1055	833	675	558	469	399
7000	2.65	144.8	7794	4384	2806	1949	1432	1096	866	701	580	487	415

Note: Shaded area exceeds maximum distance between supports. Pillow blocks are required.

\*Shaft diameter is based on 0.08 degrees twist per foot of length.

\*\*Maximum distance between supports is based on a maximum allowable deflection of 0.01 inches per foot of length.

\*\*\*Maximum allowable RPMs is based on 80% of critical shaft speed.

## Length Specifying Information

Joyce shafts can be ordered in 1/16 inch increments of length. When specifying shaft length, please refer to the table below to determine the decimal code for fractions of length.

Fraction	0	1/16	1/8	3/16	1/4	5/16	3/8	7/16	1/2	9/16	5/8	11/16	3/4	13/16	7/8	15/16
Decimal	.00	.06	.13	.19	.25	.31	.38	.44	.5	.56	.63	.69	.75	.81	.88	.94

## Ordering Information

- Example: A. For a 1/2" dia. x 33 3/8" long      Part Number = **S50-33.38**  
 B. For a 1 1/4" dia. x 110" long              Part Number = **S125-110.00**  
 C. For a 2 1/4" dia. x 58 7/16" long          Part Number = **S225-58.44**

Note: Drawings are artist's conception — not for certification; dimensions are subject to change without notice.

# CONTROLS MOTOR STARTERS

Joyce motor starters are the heart of a basic control system for a motorized jack, actuator, electric cylinder, or ComDRIVE® system. Motor starters include extend and retract push buttons for momentary operation; an illuminated power-on light lets operators easily determine if there is power to the system.

## Other standard features:

- Limit switch terminals for two LS8-402 end-of-travel limits
- 1/3 - 15 HP motors standard
- 208, 230, 460, and 575 volts standard, three-phase power requirements
- NEMA 4 enclosure
- All three-phase motor starters include IEC motor overload protection

## Ordering information:

Each model's part number begins with the prefix 07990377. To this prefix, add the appropriate suffix from the chart below. For example: 07990377-17 refers to a motor starter for a 1 1/2 horsepower, 208 volt motor.



Motor HP Starter Part Number Suffix				
Motor HP	Voltage			
	208	230	460	575
1/3	-1	-2	-3	-4
1/2	-5	-6	-7	-8
3/4	-9	-10	-11	-12
1	-13	-14	-15	-16
1 1/2	-17	-18	-19	-20
2	-21	-22	-23	-24
3	-25	-26	-27	-28
5	-29	-30	-31	-32
7 1/2	-33	-34	-35	-36
10	-37	-38	-39	-40
15	-41	-42	-43	-44

Standard Dimensions			
Amp Rating*	A	B	C
≤ 25 amp	12	12	6.64
> 25 amp	14	12	6.64

\*Amp rating is dependant on HP and voltage.

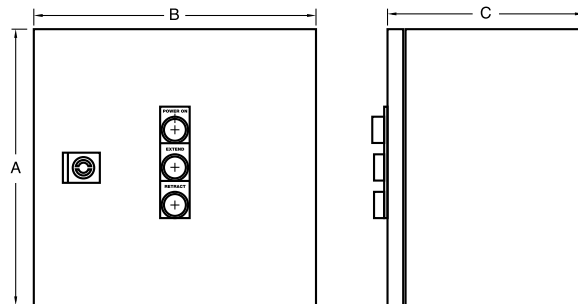

## Many options are available including:

- NEMA 4X enclosure
- 50 Hz motors
- International voltages
- Single-phase motors
- Multiple starters in a single enclosure
- Starters for larger horsepower motors
- Explosion-proof enclosure
- Maintained contact control
- Stack lights
- Audible alarm
- Wiring for LS7 and LS8-404 and other limits

Note: Drawings are artist's conception — not for certification; dimensions are subject to change without notice.



# CONTROLS VARIABLE SPEED POSITIONING SYSTEM

Joyce Variable Speed Positioning System (VSPS) is a programmable controller that increases the capability of motorized jacks by allowing the operator to easily program up to ten stopping positions.

It is housed in two NEMA 4 enclosures, one for the VFD the other for the PLC (as shown). The VSPS includes an HMI display that indicates the current position as well as the stopping location.

## Other standard features:

- Limit switch terminals for two LS8-402 end-of-travel limits
- Speed control dial (real time)
- Emergency stop push button
- 1/3 – 3 HP motor control standard
- 208, 230, 460 and 575 volts standard, three-phase power requirements
- 3" HMI display
- Manual jog

## Ordering information:

Each model's part number begins with the prefix 07990951. To this prefix add the appropriate suffix from the chart below. For example: 07990951-2 refers to a VSPS control for a 1/3 horsepower, 230 volt motor.

Motor HP Starter Part Number Suffix			
Motor HP	Voltage		
	208	230	460
1/3	-1	-2	-3
1/2	-5	-6	-7
3/4	-9	-10	-11
1	-13	-14	-15
1 1/2	-17	-18	-19
2	-21	-22	-23
3	-25	-26	-27

Standard Dimensions				
Item	Motor HP	A	B	C
PLC Box	1/3 - 3	12"	12"	6"
VFD Box	1/3 - 3	20"	20"	10"

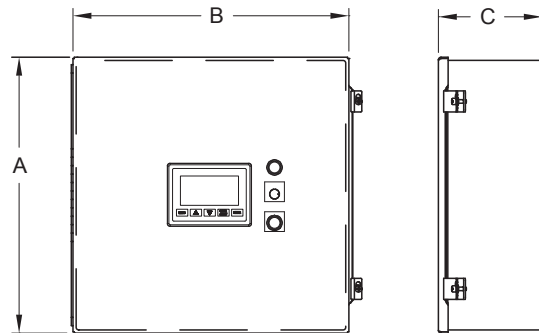

## Many options are available including:

- NEMA 4X enclosure
- 50 Hz motors
- International voltages
- Single-phase motors
- 5 horsepower and larger
- Pendant controls
- Maintained contact control
- Stack lights
- Audible alarm
- Wiring for LS7 and LS8-404 and other limits

Note: Drawings are artist's conception — not for certification; dimensions are subject to change without notice.

# CONTROLS LINEAR ACTUATORS

Joyce offers a variety of control options for actuators and small horsepower systems. See the charts below for specific information describing various offerings.

## Features Include:

- NEMA 12 approved enclosure
- Rocker-type contact switch
- Momentary contact for extend/retract
- Terminal strip for motor and incoming power connections

Controls for Joyce linear actuators are shown below.

DC Actuator Controls					
Input - Output	Amp rating	Part Number	A	B	C
12 VDC - 12 VDC with wired relays	35 amp	07990812	6"	6"	4"

AC Actuator Controls					
Input - Output	Amp Rating	Part Number	A	B	C
120 VAC - 120 VAC with wired relays	15 amp	07990762-1	8"	8"	4"

## General purpose actuator controls

12 VDC Controls					
Input - Output	Amp Rating	Part Number	A	B	C
12 VDC - 12 VDC	8.5 amp	07990938	8"	8"	4"
	25 amp	07990939			
	37 amp	07990940			

120 VAC to 12 VDC Controls					
Input - Output	Amp rating	Part Number	A	B	C
120 VAC - 12 VDC	8.5 amp	07990931	16 3/8"	10 3/4"	6"
	25 amp	07990932			
	37 amp	07990933			

120 VAC Controls					
Input - Output	Amp rating	Part Number	A	B	C
120 AC - 120 VAC	15 amp	07990964	6"	6"	4"



AC and DC Controls

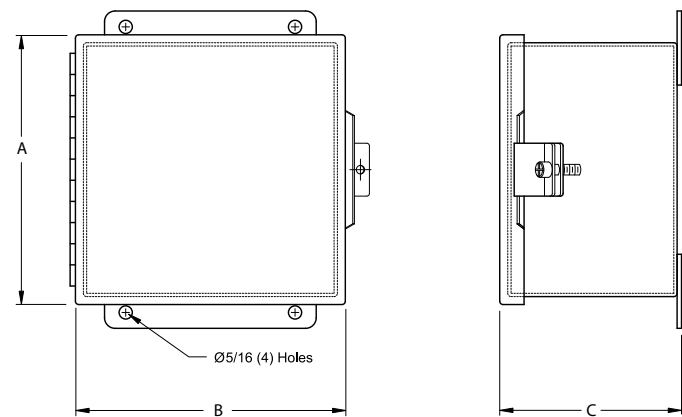

Note: All packaged controls include a terminal strip and are internally wired, ready for connection to the power source. All connections must be made according to the instructions accompanying each control package.

Note: Drawings are artist's conception — not for certification; dimensions are subject to change without notice.

# COMMON SYSTEM ARRANGEMENTS

Joyce jacks, miter gear boxes, couplings and motorized ComDRIVES® can be used in a number of system arrangements. Several are shown here.

Because jacks selected for systems have uniform lifting speeds and are fully synchronized, unevenly distributed loads can be raised, lowered, and positioned in unison. Jacks of differing capacities may be used in the same system as long as driven shafts turns per 1" of travel are the same.

Arrows indicate the rotational direction to raise the load.

## Wormgear I System Features ComDRIVE®

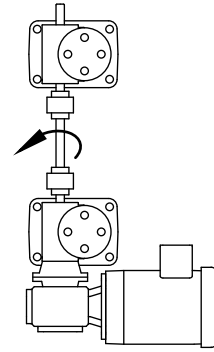

## Wormgear U System

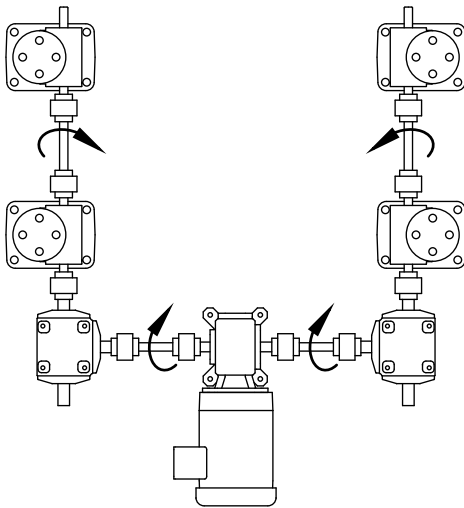

## Wormgear T System

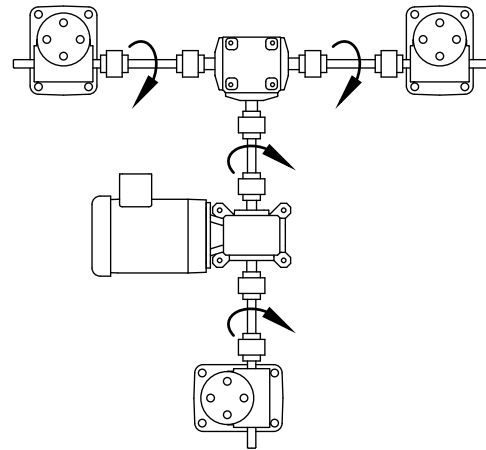

## Wormgear H System

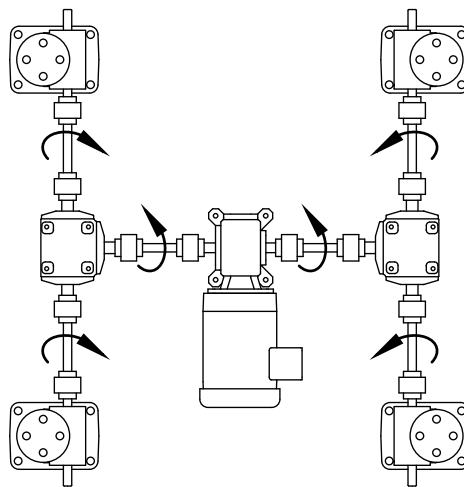

## Bevel Gear U System

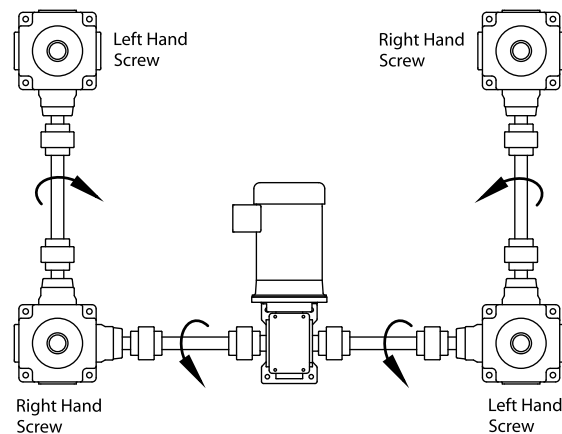



# START TO FINISH WITH JOYCE

Choose Joyce for quality industrial screw jacks, actuators, and custom lifting systems. Experience our unmatched Engineering Support and Customer Service.

## Joyce Offers More Than A Catalog Of Standard Products.

We customize our standard products to meet your requirements and specify complete systems according to your application needs. Contact an Application Engineer today!

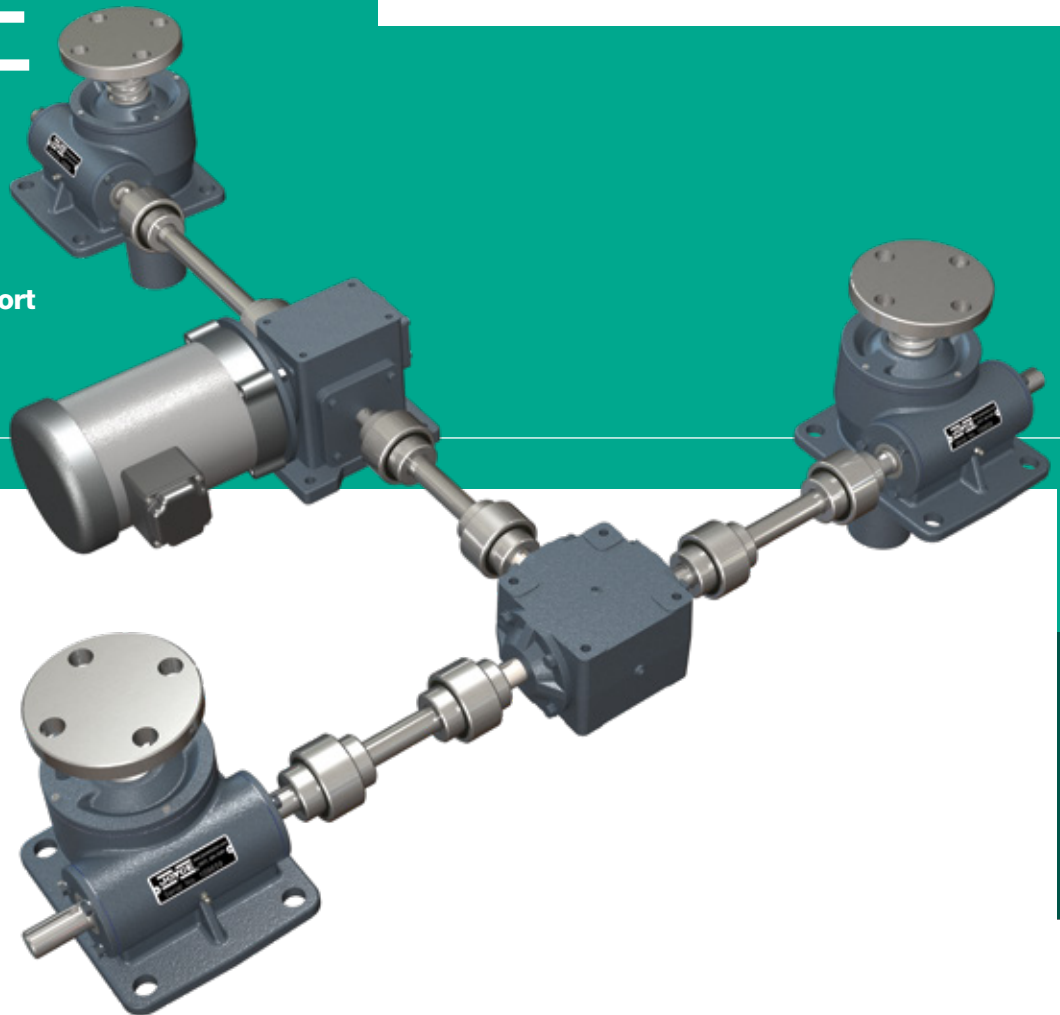

### Joyce/Dayton Corp.

P.O. Box 1630  
Dayton, Ohio 45401

Toll Free (800) 523-5204  
Phone (937) 294-6261  
Fax (937) 297-7173  
sales@joycedayton.com

[www.joycedayton.com](http://www.joycedayton.com)