

Section III
Views & Parts List
3-1 Exploded View of Translating Tube Actuator

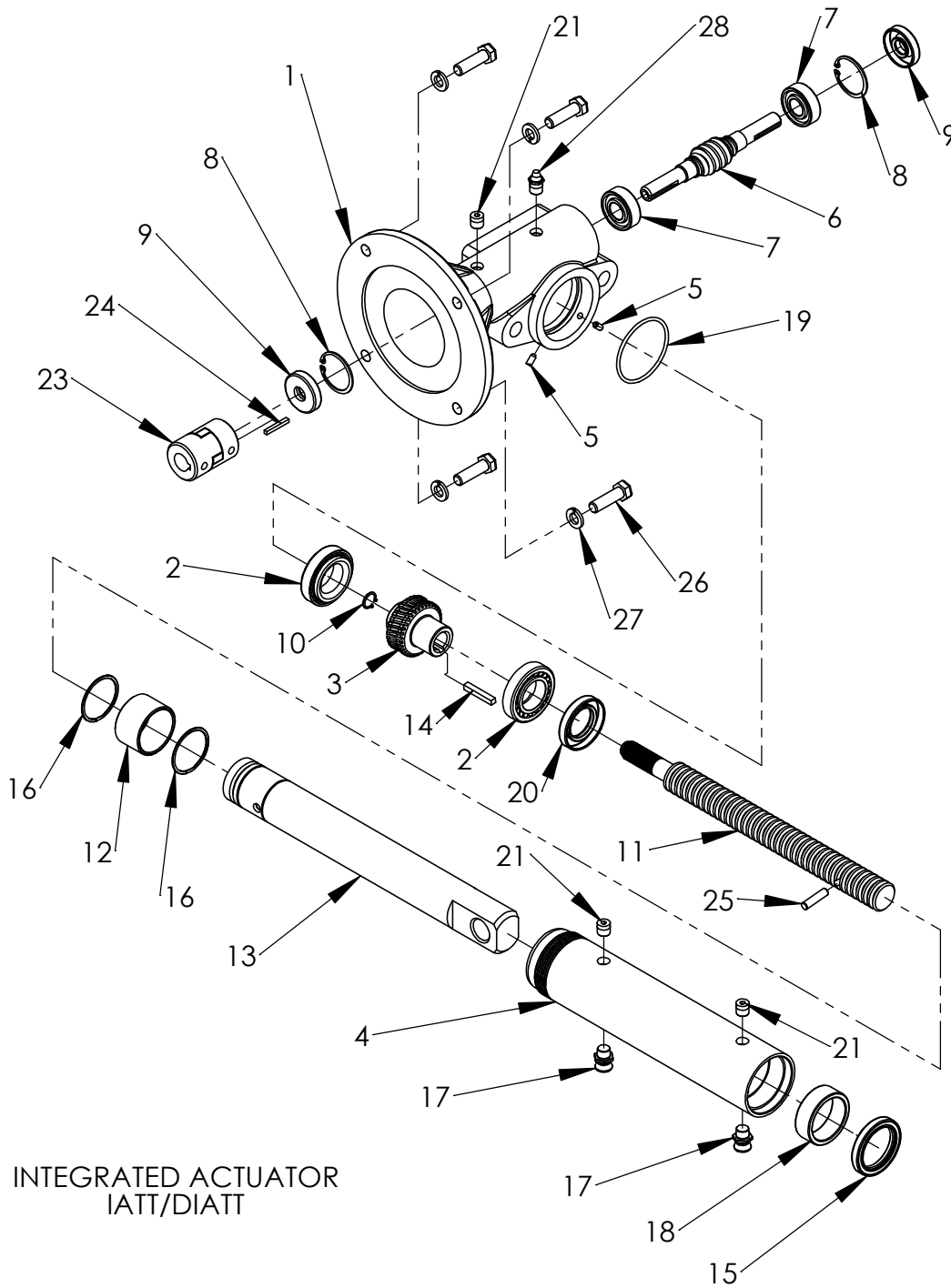

3-3 Parts List for Integrated actuator

Table 3-3 Parts list - Integrated Actuator (Acme)

Item	TRANSLATING TUBE MODEL Description (Qty.)	Item	TRAVELING NUT MODEL Description (Qty.)
1	Integrated actuator Sleeve (1)	1	Integrated actuator Sleeve(1)
2	Thrust Bearing (2)	2	Thrust Bearing (2)
3	Worm gear nut (1)	3	Worm gear nut (1)
4	Protection Tube (1)	4	Sleeve Cap (1)
5	Set Screw (2)	5	Set Screw (2)
6	Worm (1)	6	Worm (1)
7	Worm Shaft Bearing (2)	7	Worm Shaft Bearing (2)
8	Retaining Ring (2)	8	Retaining Ring (2)
9	Worm Shaft Seal (2)	9	Worm Shaft Seal (2)
10	Retaining Ring (1)	10	Retaining Ring (1)
11	Jack Screw (1)	11	Jack Screw (1)
12	Translating Tube Bushing (1)	12	Traveling Nut (1)
13	Translating Tube AY (1)	13	Key (1)
14	Key (1)	14	Dowel Pin (1)
15	Seal (1)	15	Seal (1)
16	Retaining Ring (2)	16	O Ring (1)
17	Air Vent 1/8 NPT (2)	17	Coupling (1)
18	Guide Bearing, LA15 (1)	18	Key (1)
19	O Ring (1)	19	Grease Fitting 1/8 NPT (1)
20	Seal (1)	20	Hex Head Screw (4)
21	Pipe Plug 1/8-27 NPT (3)	21	Lock Washer (4)
22	Large Decal (1)	22	Pipe Plug 1/8-27 NPT (1)
23	Coupling (1)	23	Name Plate (1)
24	Key (1)	24	Drive Screw (2)
25	Dowel Pin (1)		
26	Hex Head Screw (4)		
27	Lock Washer (4)		
28	Grease Fitting 1/8 NPT (1)		
29	Name Plate (1)		
30	Drive Screw (2)		