

# ACCESSORIES SHAFTING

Joyce shafting matches perfectly with Joyce jacks and couplings to meet a wide range of system requirements. Shafting is made from cold-finished 1018 steel, with ends machined to ANSI-standard keyways. For further information on common jack system arrangements, refer to page 195.

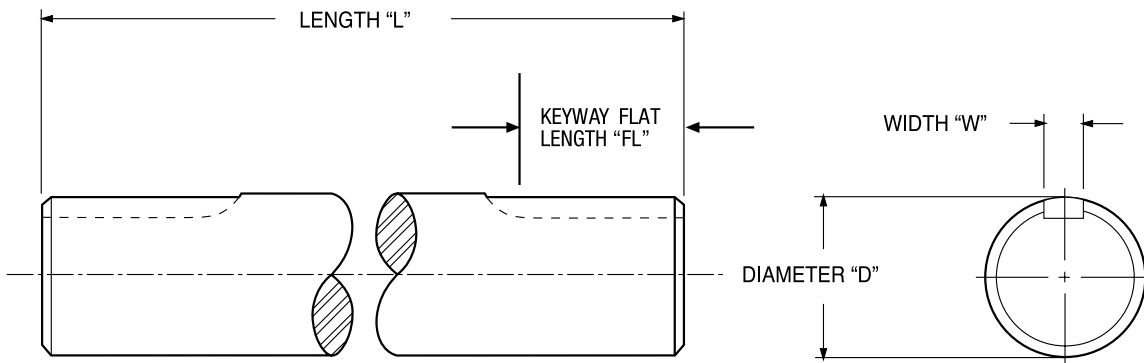

**Dimensions and Minimum Shaft Length**

Model		S50	S63	S75	S88	S100	S113	S125	S138	S150	S163	S175	S188	S200	S213	S225	S238	S250	S262
Minimum Shaft Length* "L"	Flange	7	7	7	7	7	7	7	7	7	7	7	8	8	10	10	10	10	10
	Sleeve	5	5	5	5	5	6	6	6	7	7	7	8	8	10	10	10	10	10
Shaft Diameter "D" Inches	Nominal	1/2	5/8	3/4	7/8	1	1 1/8	1 1/4	1 3/8	1 1/2	1 5/8	1 3/4	1 7/8	2	2 1/8	2 1/4	2 3/8	2 1/2	2 5/8
	Actual	.500 .498	.625 .623	.750 .748	.875 .873	1.000 .998	1.125 1.123	1.250 1.248	1.375 1.373	1.500 1.498	1.625 1.623	1.750 1.748	1.875 1.872	2.000 1.997	2.125 2.122	2.250 2.247	2.375 2.372	2.500 2.497	2.625 2.621
Keyway Width "W"		1/8	3/16	3/16	3/16	1/4	1/4	1/4	5/16	3/8	3/8	3/8	1/2	1/2	1/2	5/8	5/8	5/8	5/8
Keyway Flat Length "FL"		1.25	1.25	1.25	1.25	1.25	1.5	1.5	1.75	1.75	1.75	2	2	2	2.5	2.5	2.5	2.5	2.5

\*These are the minimum shaft lengths that can be ordered when Joyce Model "S" sleeve type couplings or "F" flange-type couplings are selected. See pages 188 and 189 for coupling information.

Note: Drawings are artist's conception — not for certification; dimensions are subject to change without notice.

# ACCESSORIES SHAFTING

## To use this chart, follow these steps:

1. Find a "Shaft Torque" value in the far left column that is greater than, or equal to, your calculated torque value.
2. Move to the second column to find your "Nominal Shaft Diameter" (round up to arrive at an offered shaft size).
3. The third column shows the maximum allowable shaft span before supports (pillow blocks) are required.
4. Compare your actual shaft speed (RPM) with the maximum allowable speed (RPM) for the shaft you have chosen. If you are above the allowable shaft speed, then increase the shaft size until it falls into the allowable range.

Diameter Selection Chart			Maximum Allowable RPMs***										
Shaft Torque (Inch/Lbs.)	Nominal Shaft Diameter* (Inches)	Maximum** Distance Between Supports (Inches)	Shaft Lengths (Inches)										
			36	48	60	72	84	96	108	120	132	144	156
20	0.51	54.6	1802	1014	649	450	331	253	200	162	134	113	96
40	0.73	61.3	2143	1205	771	536	394	301	238	193	159	134	114
50	0.81	65.5	2372	1334	854	593	436	333	264	213	176	148	126
80	0.87	68.8	2548	1433	917	637	468	358	283	229	190	159	136
100	0.92	71.4	2695	1516	970	674	495	379	299	243	200	168	143
150	1.01	76.3	2982	1677	1074	746	548	419	331	268	222	186	159
200	1.09	80.1	3204	1802	1154	801	589	451	356	288	238	200	171
250	1.15	83.1	3388	1906	1220	847	622	476	376	305	252	212	180
300	1.21	85.7	3546	1995	1277	887	651	499	394	319	264	222	189
350	1.25	87.9	3686	2073	1327	921	677	518	410	332	274	230	196
400	1.30	89.9	3811	2144	1372	953	700	536	423	343	283	238	203
450	1.34	91.7	3925	2208	1413	981	721	552	436	353	292	245	209
500	1.37	93.3	4029	2266	1451	1007	740	567	448	363	300	252	215
600	1.44	96.2	4217	2372	1518	1054	775	593	469	380	314	264	225
700	1.49	98.7	4383	2465	1578	1096	805	616	487	394	326	274	233
800	1.54	100.9	4532	2549	1631	1133	832	637	504	408	337	283	241
900	1.59	102.9	4667	2625	1680	1167	857	656	519	420	347	292	249
1000	1.63	104.7	4792	2695	1725	1198	880	674	532	431	356	299	255
1250	1.72	108.7	5067	2250	1824	1267	931	712	563	456	377	317	270
1500	1.80	112.0	5303	2983	1909	1326	974	746	589	477	394	331	282
1750	1.92	114.9	5511	3100	1984	1378	1012	775	612	496	410	344	293
2000	1.94	117.5	5698	3205	2051	1425	1047	801	633	513	424	356	303
2250	2.00	119.8	5869	3301	2113	1467	1078	825	652	528	437	367	313
2500	2.05	122.0	6025	3389	2169	1506	1107	847	669	542	448	377	321
3000	2.15	125.7	6306	3547	2270	1577	1158	887	701	568	469	394	336
3250	2.19	127.4	6434	3619	2316	1608	1182	905	715	579	479	402	343
3500	2.23	129.0	6554	3687	2359	1639	1204	922	728	590	487	410	349
4000	2.31	131.9	6776	3812	2440	1694	1245	953	753	610	504	424	361
4500	2.38	134.5	6979	3926	2512	1745	1282	981	775	628	519	436	372
5000	2.44	136.9	7165	4030	2579	1791	1315	1008	796	645	533	448	382
6000	2.55	141.1	7499	4218	2700	1875	1377	1055	833	675	558	469	399
7000	2.65	144.8	7794	4384	2806	1949	1432	1096	866	701	580	487	415

Note: Shaded area exceeds maximum distance between supports. Pillow blocks are required.

\*Shaft diameter is based on 0.08 degrees twist per foot of length.

\*\*Maximum distance between supports is based on a maximum allowable deflection of 0.01 inches per foot of length.

\*\*\*Maximum allowable RPMs is based on 80% of critical shaft speed.

## Length Specifying Information

Joyce shafts can be ordered in 1/16 inch increments of length. When specifying shaft length, please refer to the table below to determine the decimal code for fractions of length.

Fraction	0	1/16	1/8	3/16	1/4	5/16	3/8	7/16	1/2	9/16	5/8	11/16	3/4	13/16	7/8	15/16
Decimal	.00	.06	.13	.19	.25	.31	.38	.44	.5	.56	.63	.69	.75	.81	.88	.94

## Ordering Information

- Example: A. For a 1/2" dia. x 33 3/8" long      Part Number = **S50-33.38**  
 B. For a 1 1/4" dia. x 110" long              Part Number = **S125-110.00**  
 C. For a 2 1/4" dia. x 58 7/16" long          Part Number = **S225-58.44**

Note: Drawings are artist's conception — not for certification; dimensions are subject to change without notice.