

# BALL SCREW JACKS

## 10 TON - 2" SCREW HEAVY DUTY HIGH LEAD

HWB 810 / HWB 2410

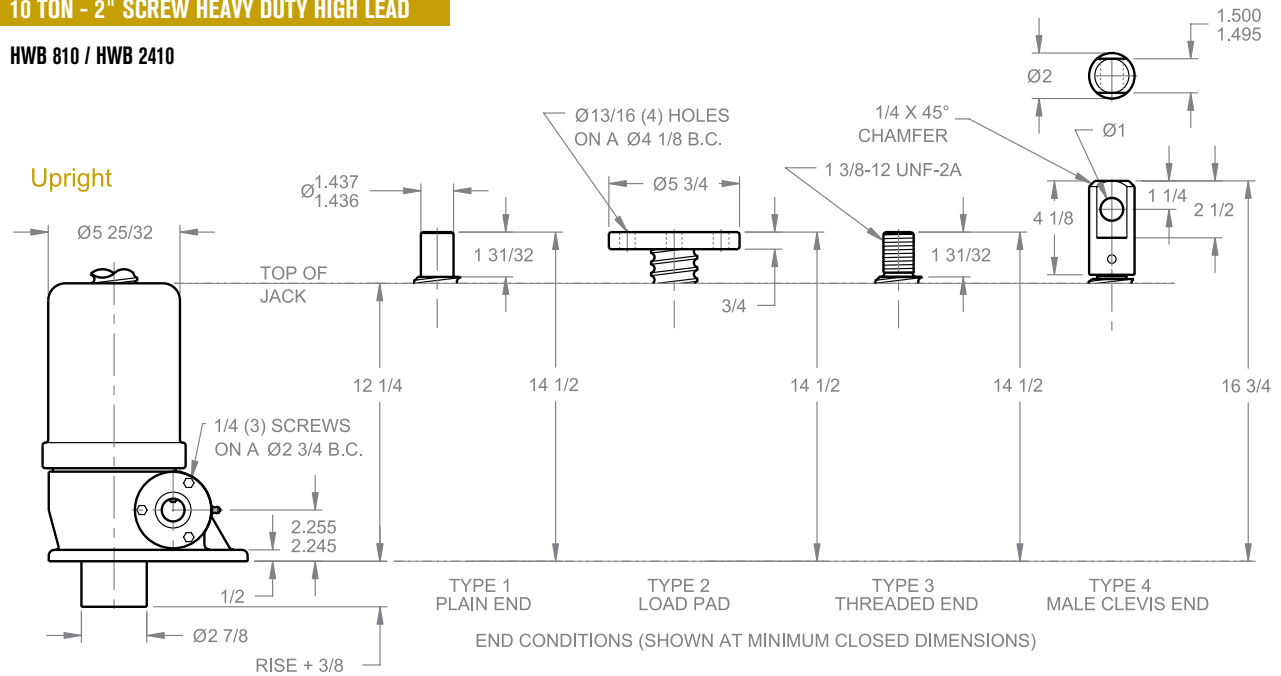

### Upright traveling nut

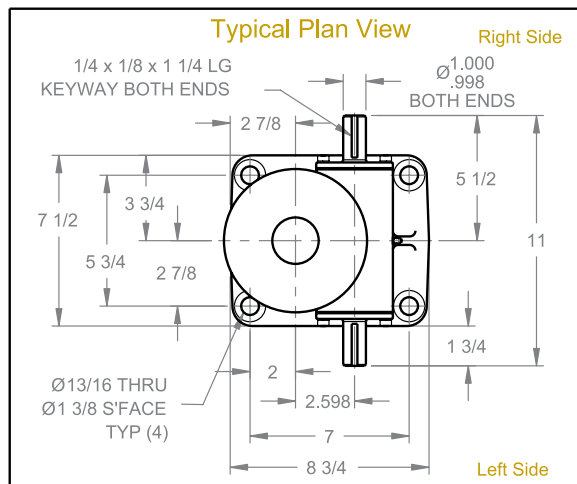
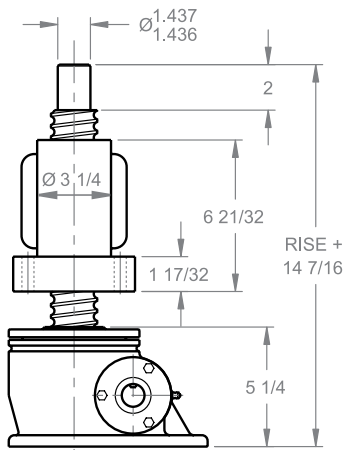

### Inverted traveling nut

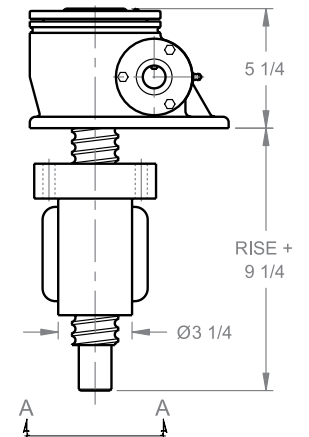

### Inverted

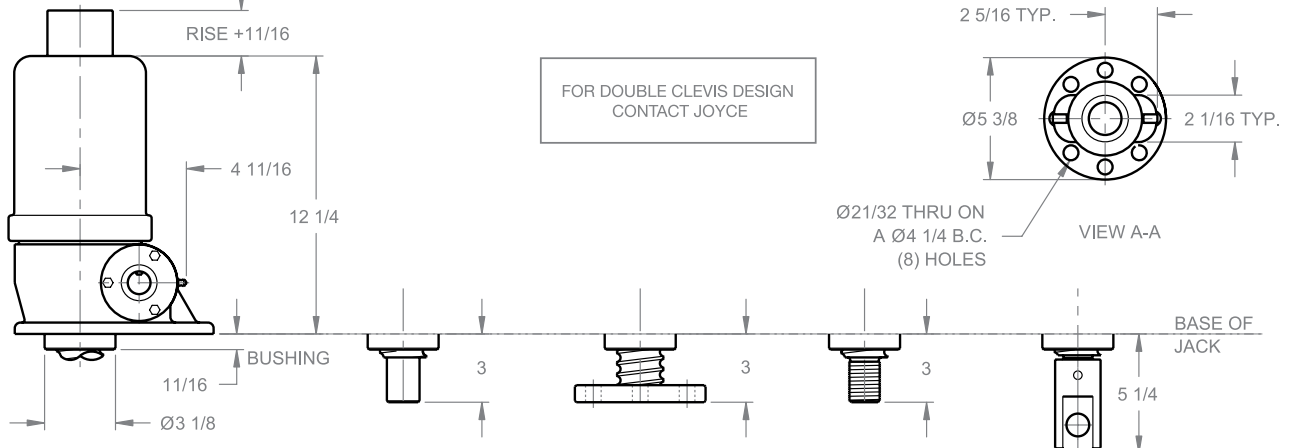

Note: Drawings are artist's conception — not for certification; dimensions are subject to change without notice.